

ARM A
PRIMUM
PERFECTUS
SOLIS
CASTRUM
FORMO
MOVENTIS
GRACILIS
ALTUM
ENERGY
KONDENS ENTEGRE CEPHE
RENOVATIO
INGENTIS
SOLIDUM
VIVAL
RARUS
BELLUS
INNOVATIO ACTUS

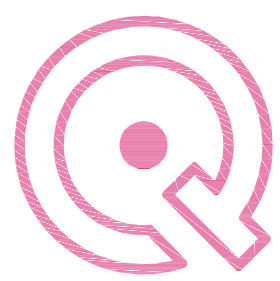

354871

Kg: 1283 gr/m
Ix: 10,93 cm⁴
Iy: 11,95 cm⁴

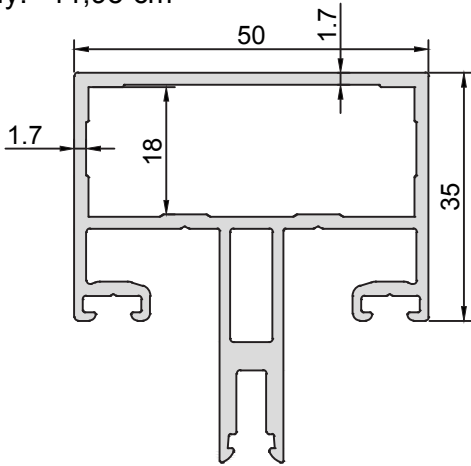

354872

Kg: 1467 gr/m
Ix: 26,56 cm⁴
Iy: 15,92 cm⁴

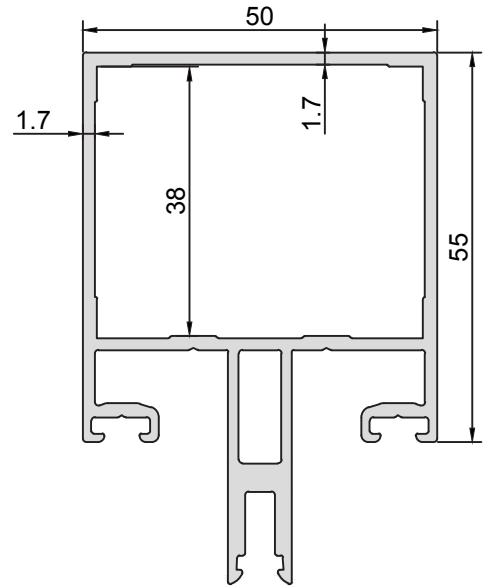

354874

Kg: 1651 gr/m
Ix: 52,42 cm⁴
Iy: 19,88 cm⁴

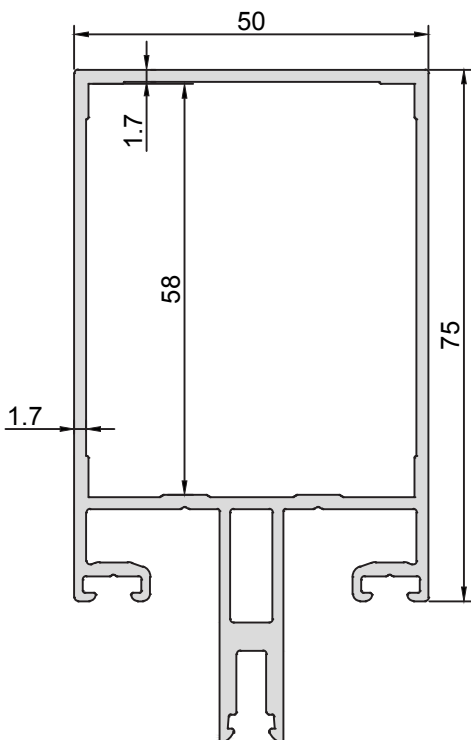

354875

Kg: 1785 gr/m
Ix: 56,01 cm⁴
Iy: 21,73 cm⁴

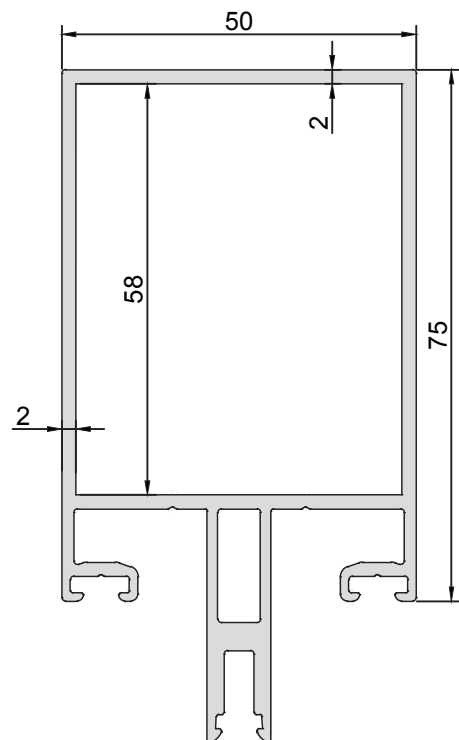

354873

Kg: 1568 gr/m

Ix: 28,18 cm⁴

Iy: 17,13 cm⁴

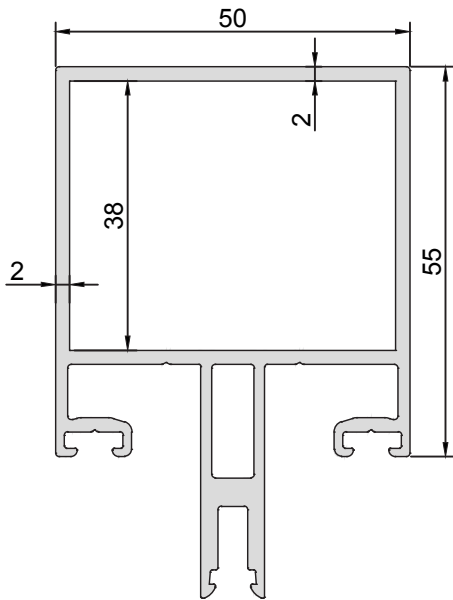

354876

Kg: 1835 gr/m

Ix: 90,05 cm⁴

Iy: 23,85 cm⁴

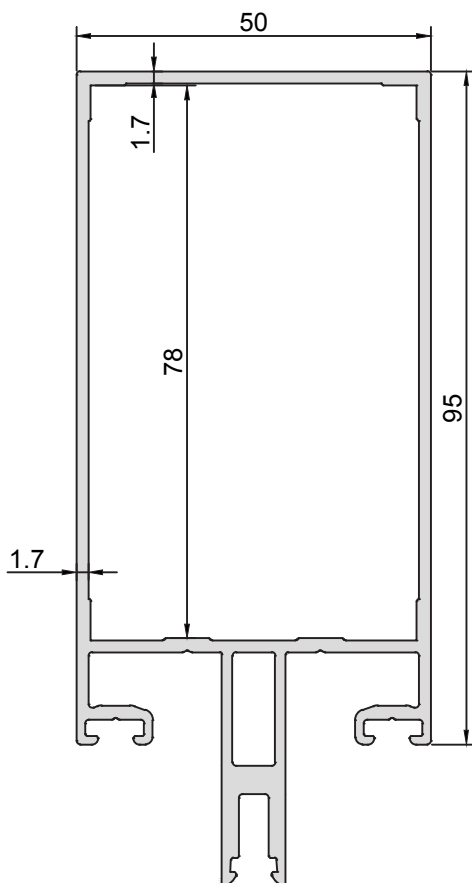

354877

Kg: 2001 gr/m

Ix: 96,69 cm⁴

Iy: 26,34 cm⁴

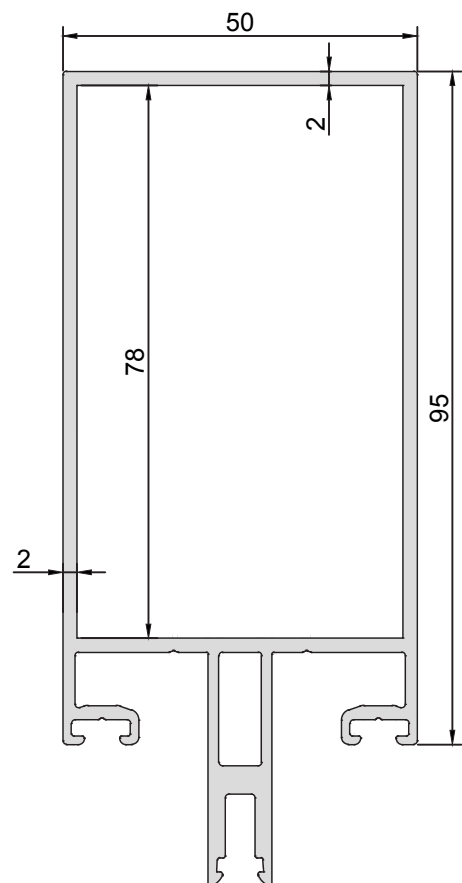

354878

Kg: 2081 gr/m
Ix: 146,5 cm⁴
Iy: 28,57 cm⁴

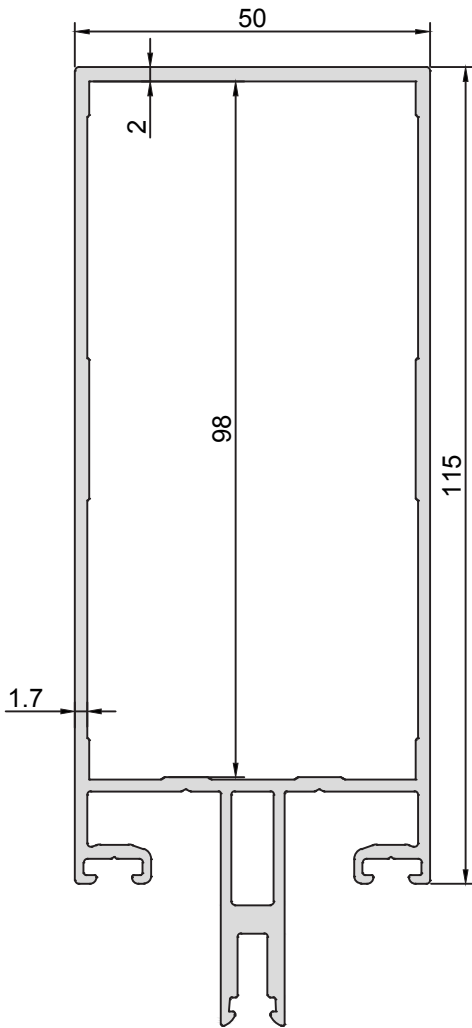

354879

Kg: 2343 gr/m
Ix: 171,1 cm⁴
Iy: 31,77 cm⁴

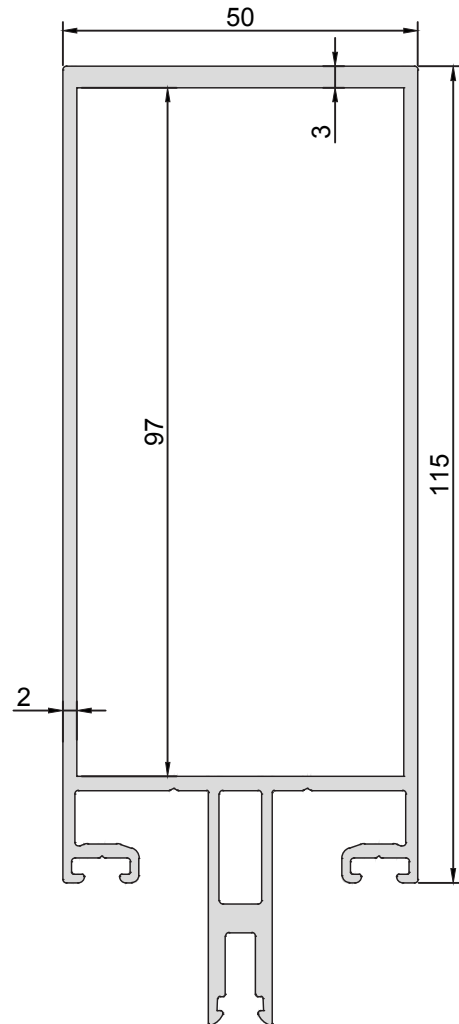

354880

Kg: 2291 gr/m
Ix: 220 cm⁴
Iy: 32,71 cm⁴

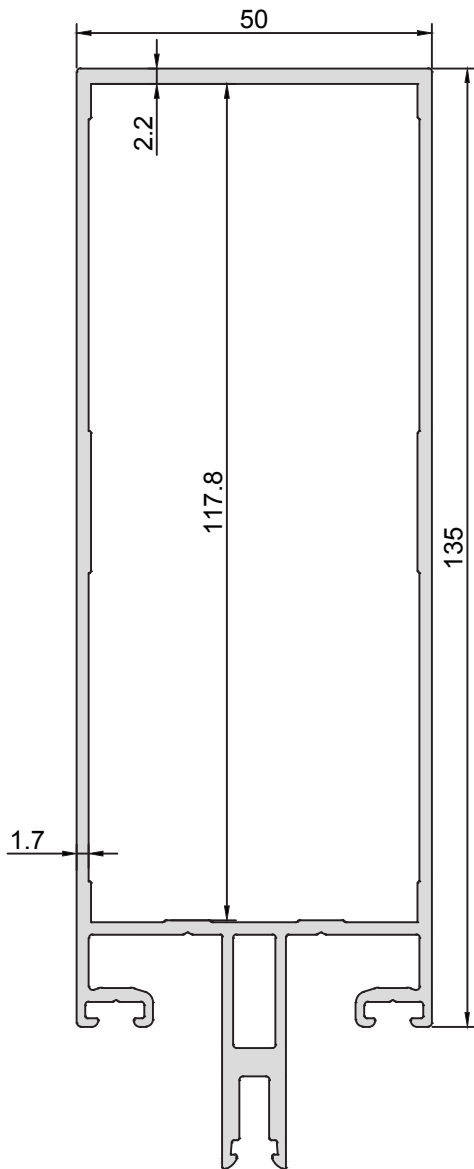

354881

Kg: 2684 gr/m
Ix: 272,6 cm⁴
Iy: 37,19 cm⁴

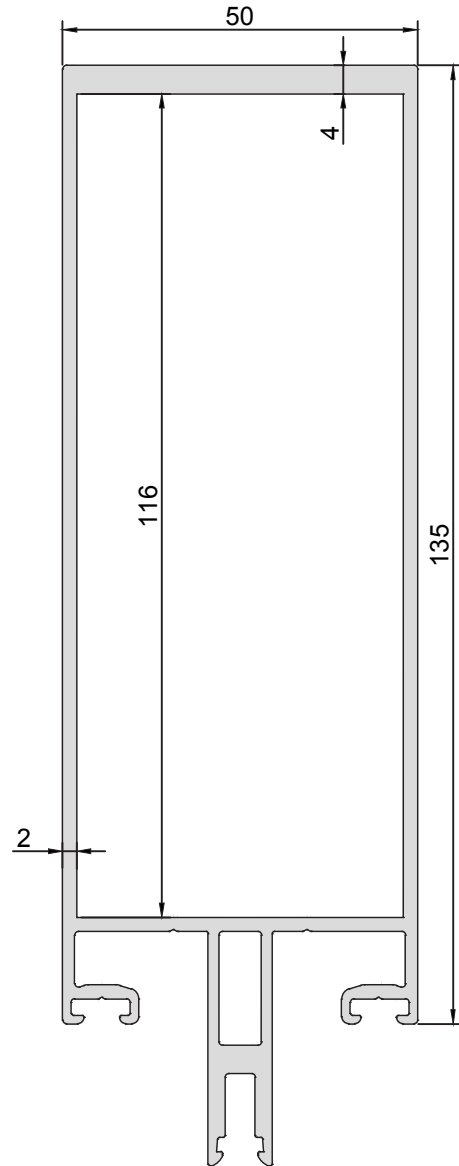

354882

Kg: 2594 gr/m
Ix: 316,7 cm⁴
Iy: 38,5 cm⁴

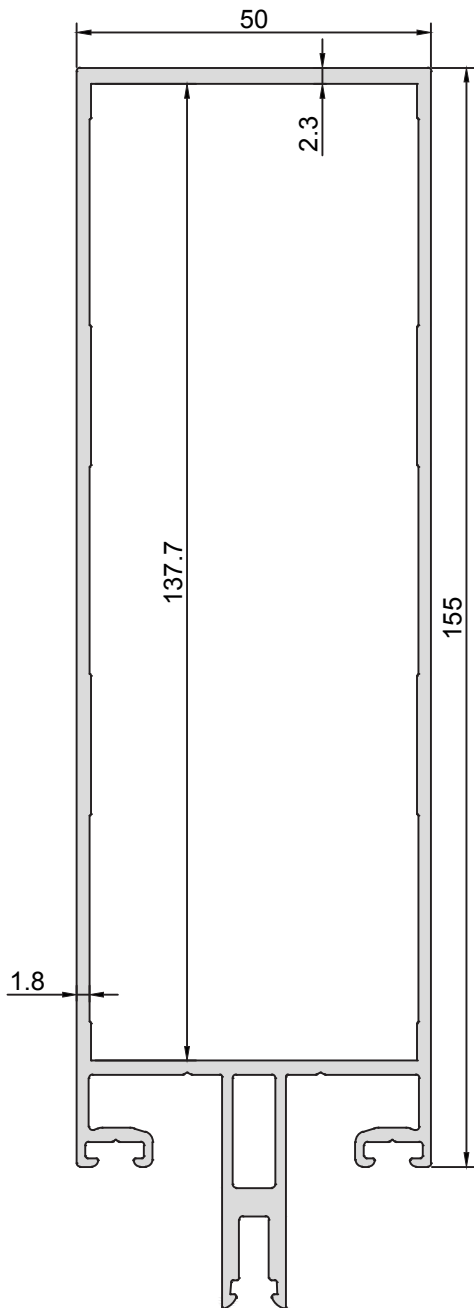

354883

Kg: 2963 gr/m
Ix: 391,2 cm⁴
Iy: 42,20 cm⁴

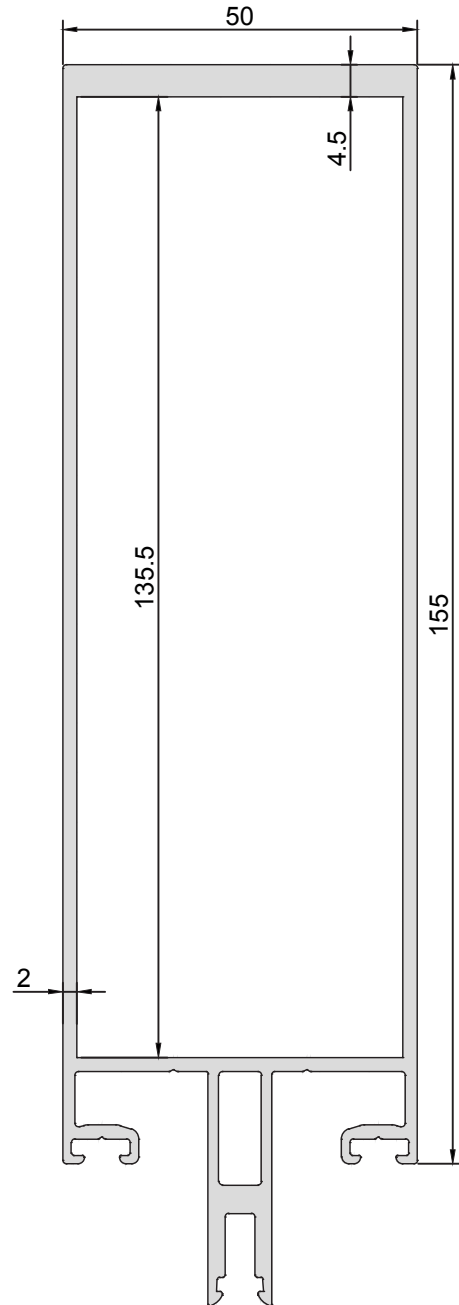

354884

Kg: 3004 gr/m
Ix: 447,3 cm⁴
Iy: 46,8 cm⁴

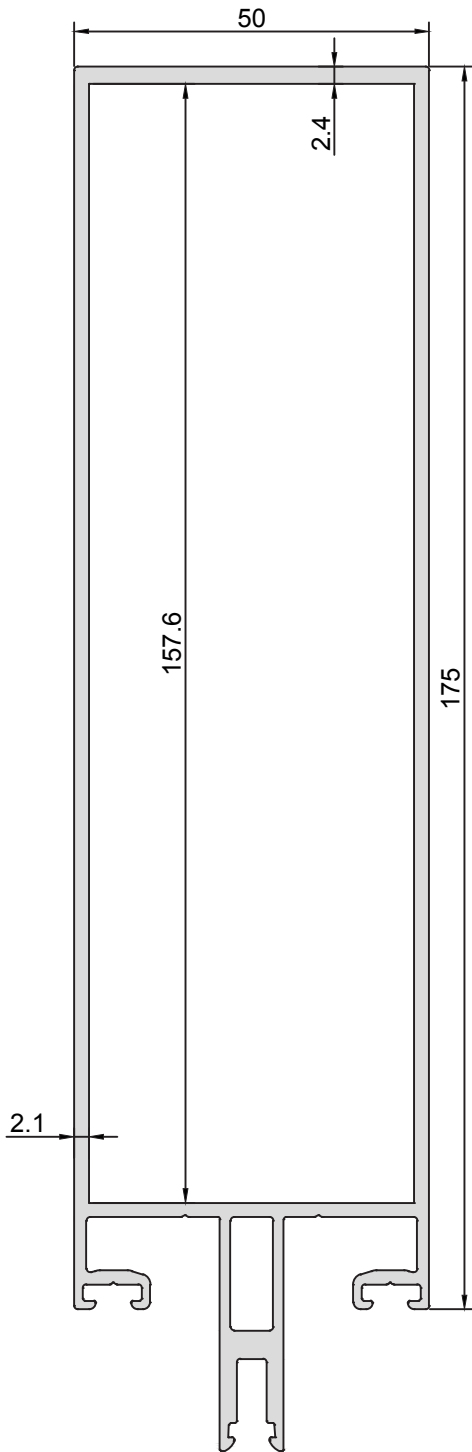

354885

Kg: 3327 gr/m
Ix: 544,5 cm⁴
Iy: 48,85 cm⁴

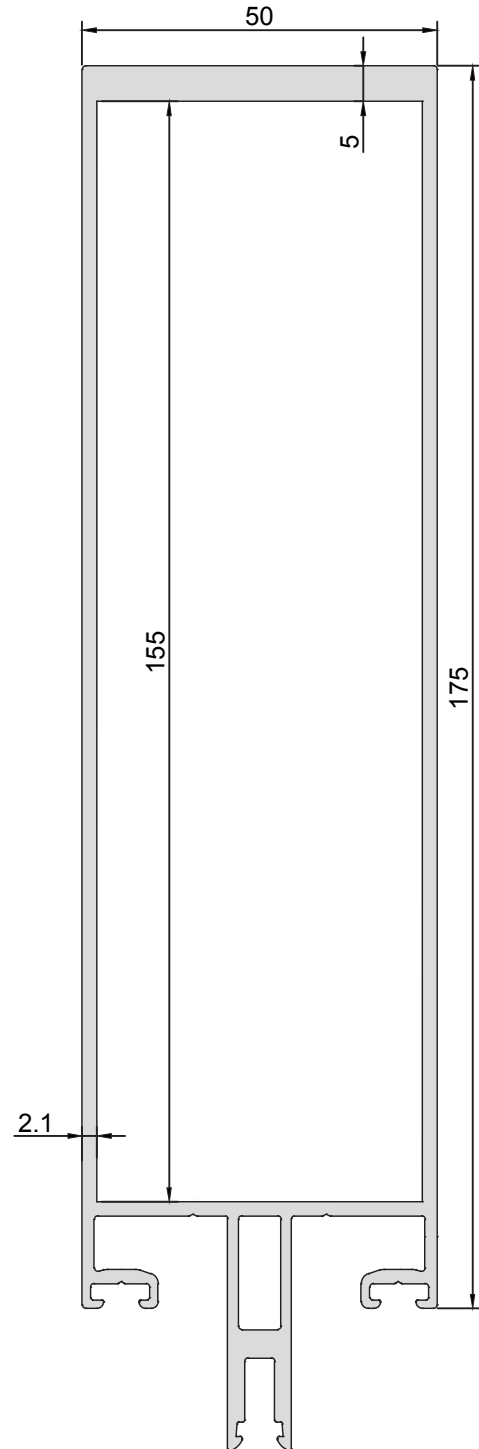

354886

Kg: 3450 gr/m
Ix: 613,1 cm⁴
Iy: 55,6 cm⁴

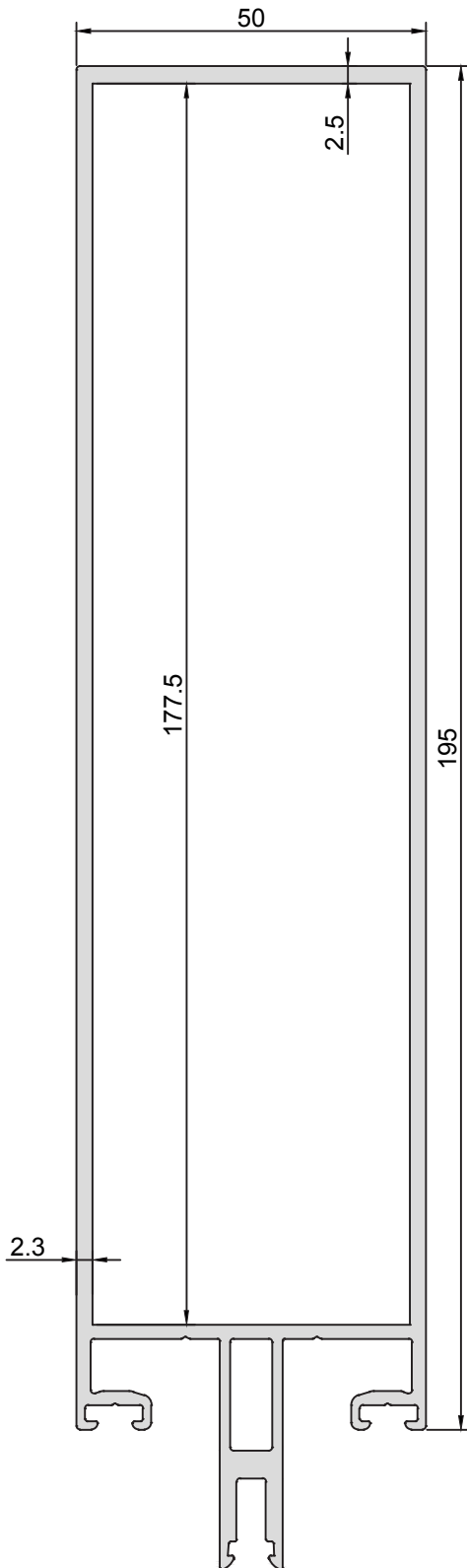

354887

Kg: 3756 gr/m
Ix: 726,4 cm⁴
Iy: 57,56 cm⁴

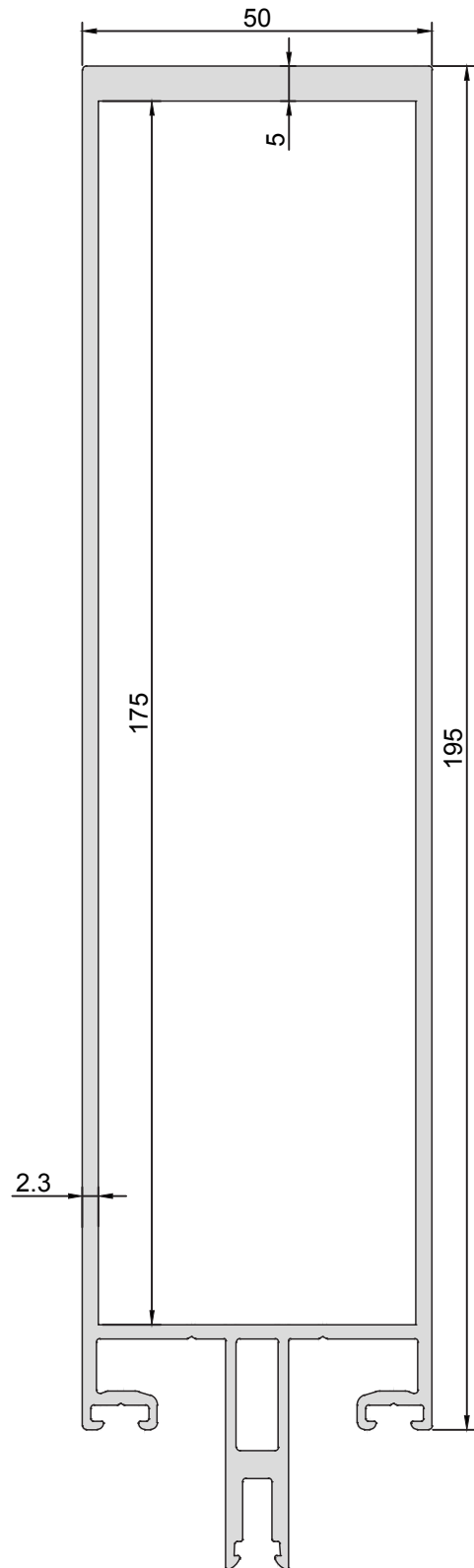

354888

Kg: 3915 gr/m
Ix: 840,6 cm⁴
Iy: 65,26 cm⁴

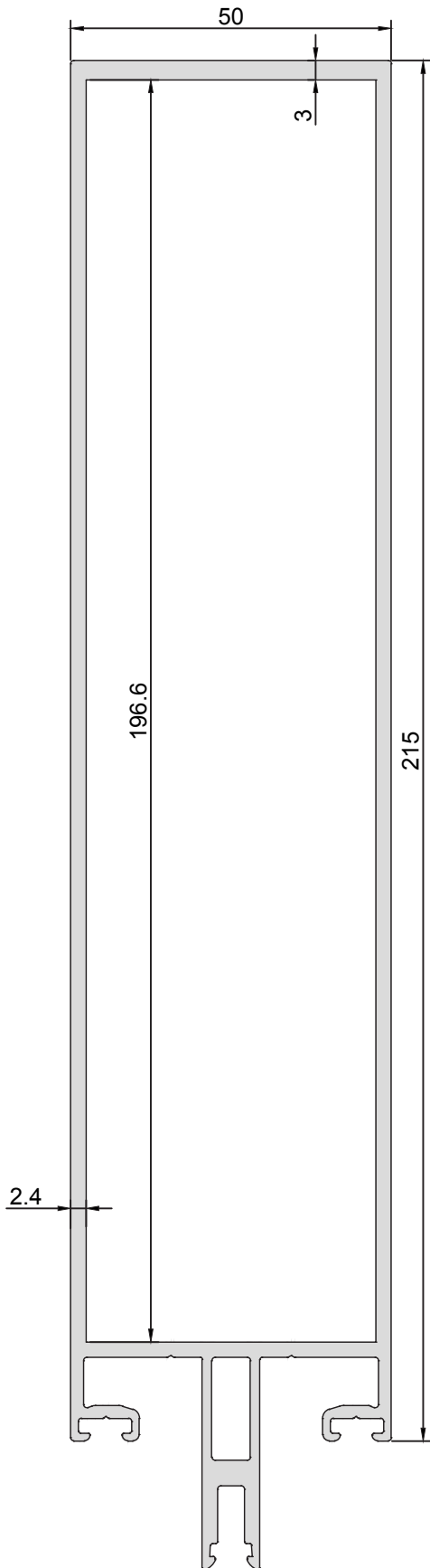

354889

Kg: 4283 gr/m
Ix: 1002 cm⁴
Iy: 65,87 cm⁴

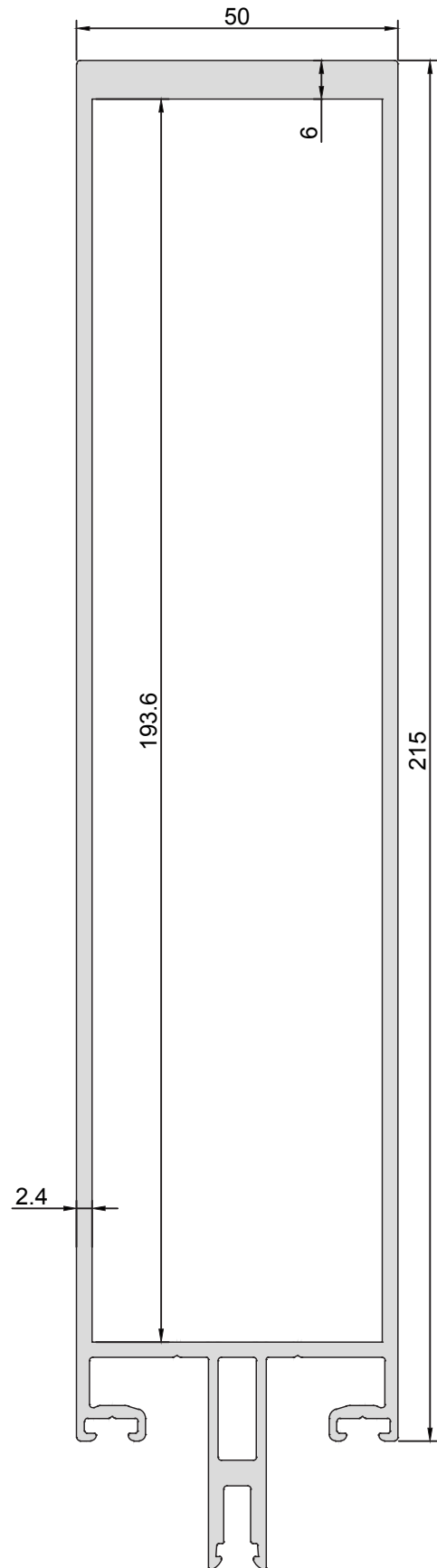

354890

Kg: 2366 gr/m
Ix: 69,5 cm⁴
Iy: 68,6 cm⁴

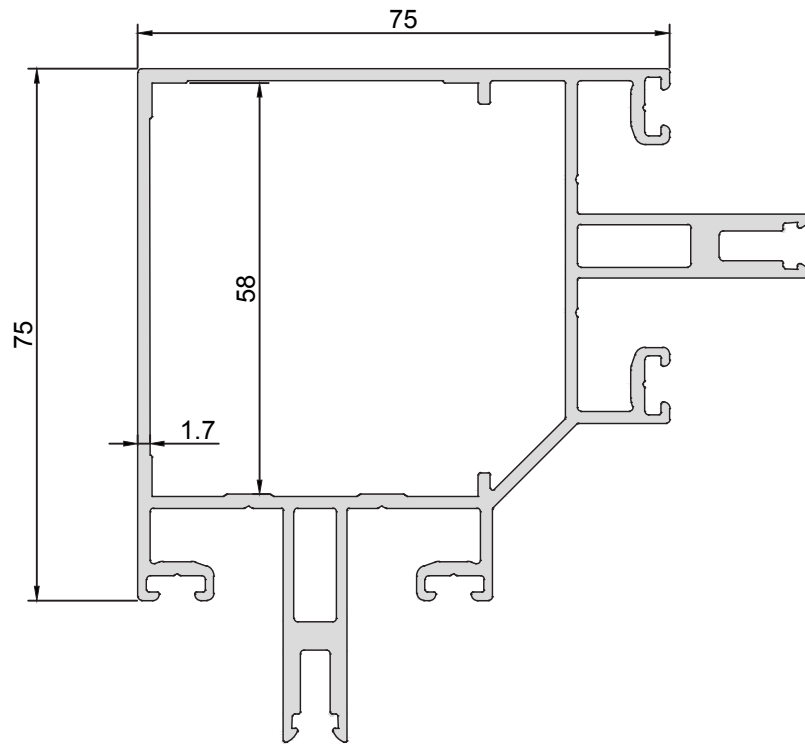

354891

Kg: 2681 gr/m
Ix: 129,5 cm⁴
Iy: 127,7 cm⁴

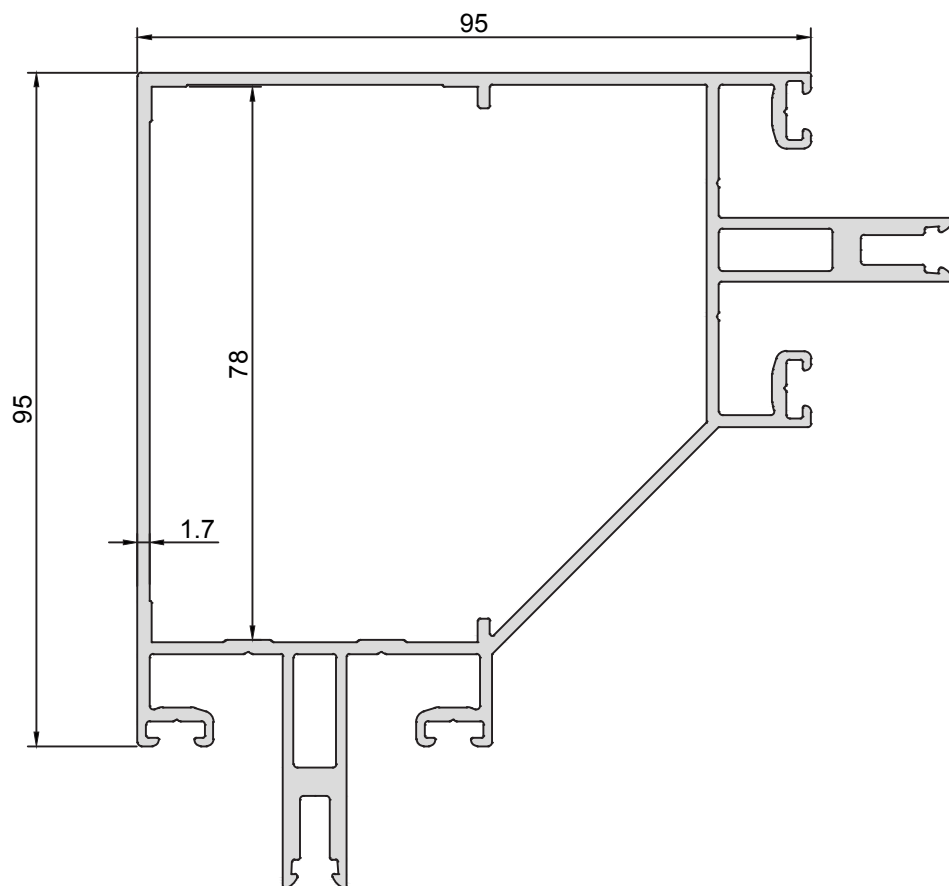

354892

Kg: 570 gr/m
Ix: 0,56 cm⁴
Iy: 3,32 cm⁴

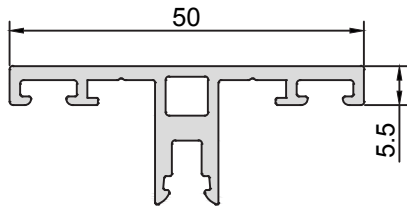

354893

Kg: 933 gr/m
Ix: 2,91 cm⁴
Iy: 7,95 cm⁴

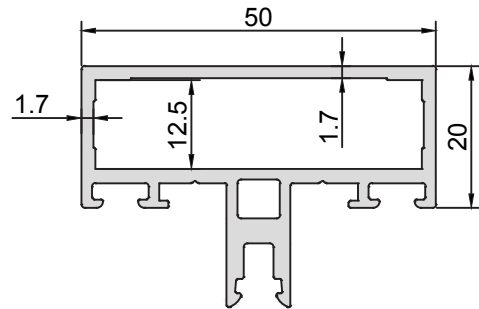

354894

Kg: 1123 gr/m
Ix: 11,8 cm⁴
Iy: 12,05 cm⁴

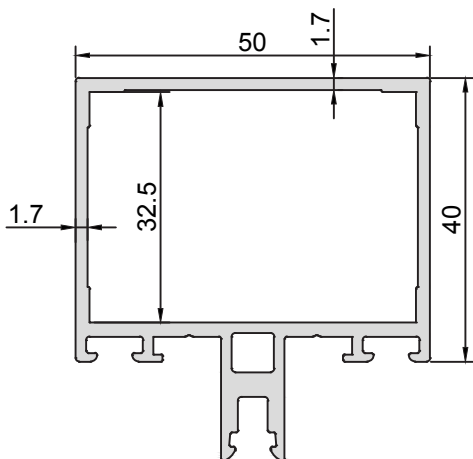

354895

Kg: 1161 gr/m
Ix: 18,59 cm⁴
Iy: 13,43 cm⁴

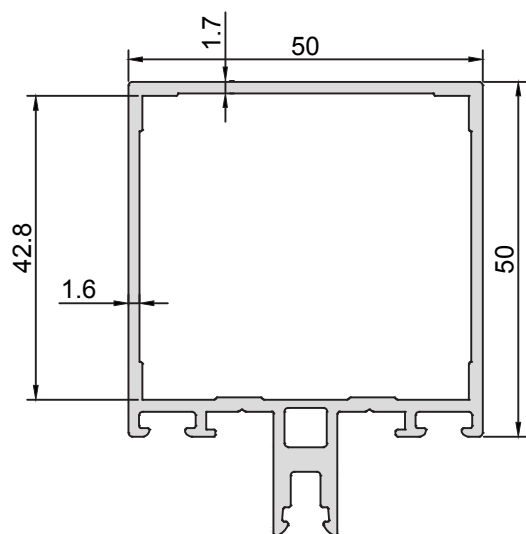

354896

Kg: 1308 gr/m
Ix: 28,8 cm⁴
Iy: 16,02 cm⁴

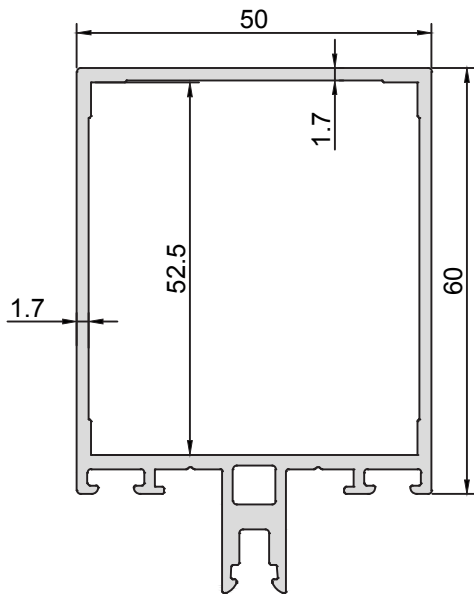

354897

Kg: 1515 gr/m
Ix: 56,17 cm⁴
Iy: 20,41 cm⁴

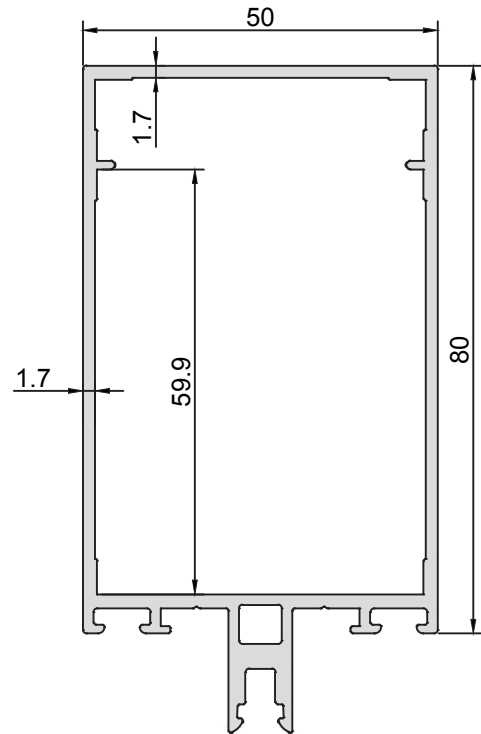

354906

Kg: 1485 gr/m
Ix: 73,68 cm⁴
Iy: 24,28 cm⁴

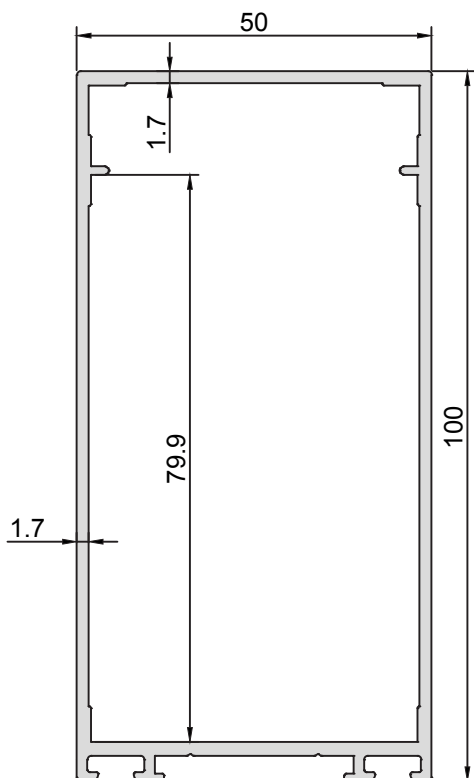

354898

Kg: 1700 gr/m
Ix: 94,45 cm⁴
Iy: 24,38 cm⁴

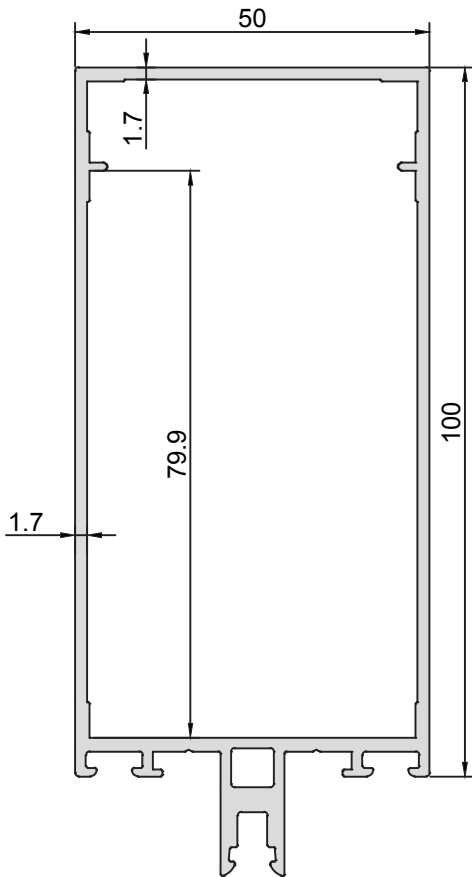

354899

Kg: 1884 gr/m
Ix: 145,2 cm⁴
Iy: 28,34 cm⁴

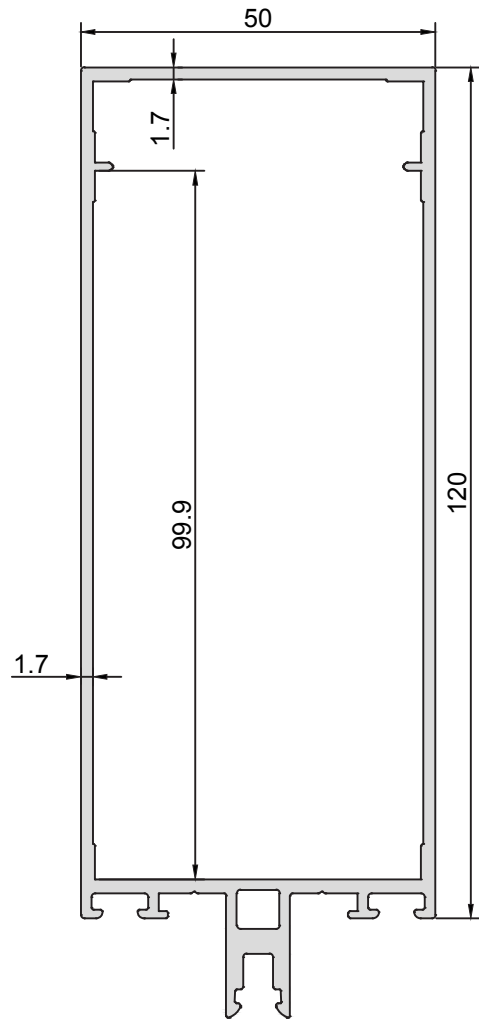

354900

Kg: 2290 gr/m
Ix: 225,7 cm⁴
Iy: 36,21 cm⁴

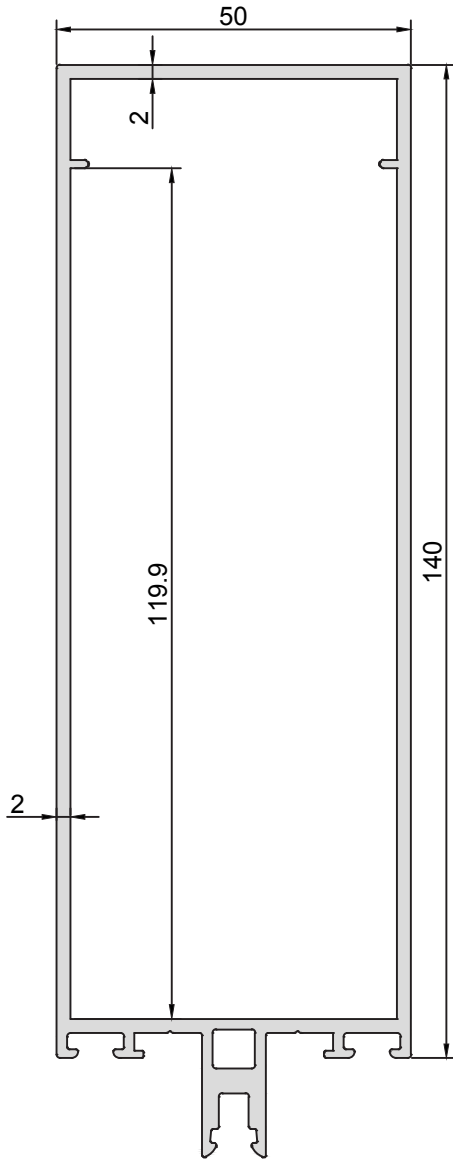

354901

Kg: 2227 gr/m
Ix: 287,6 cm⁴
Iy: 35,61 cm⁴

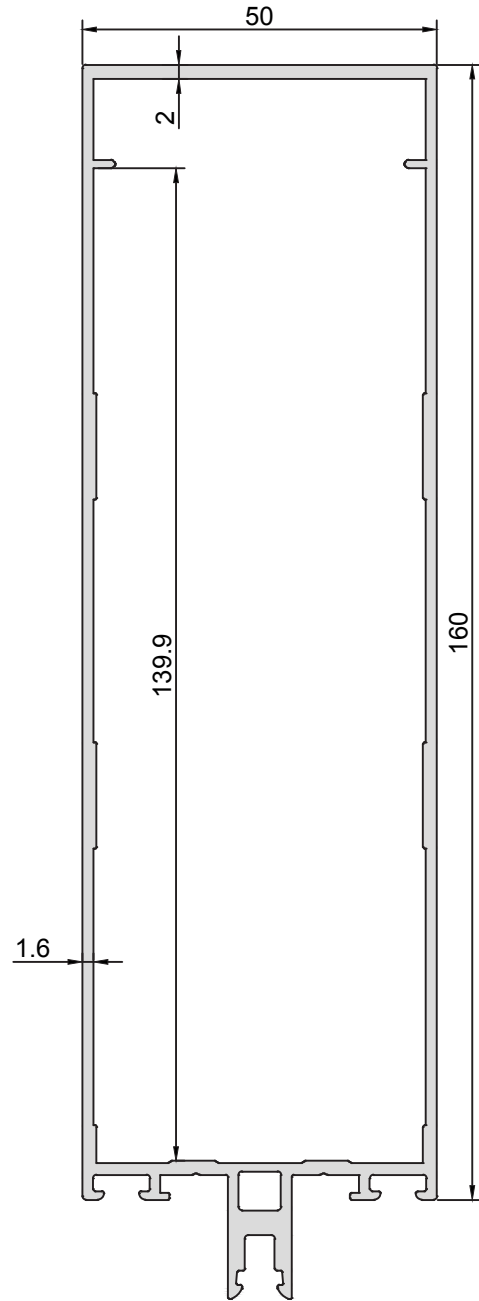

354902

Kg: 2601 gr/m
Ix: 322,4 cm⁴
Iy: 42,51 cm⁴

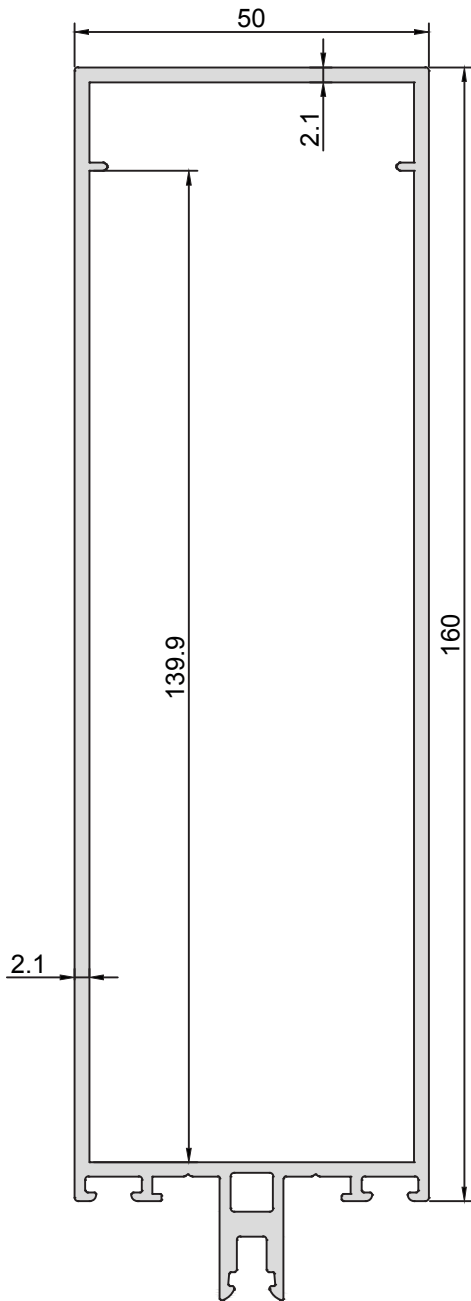

354903

Kg: 2828 gr/m
Ix: 431,7 cm⁴
Iy: 47,33 cm⁴

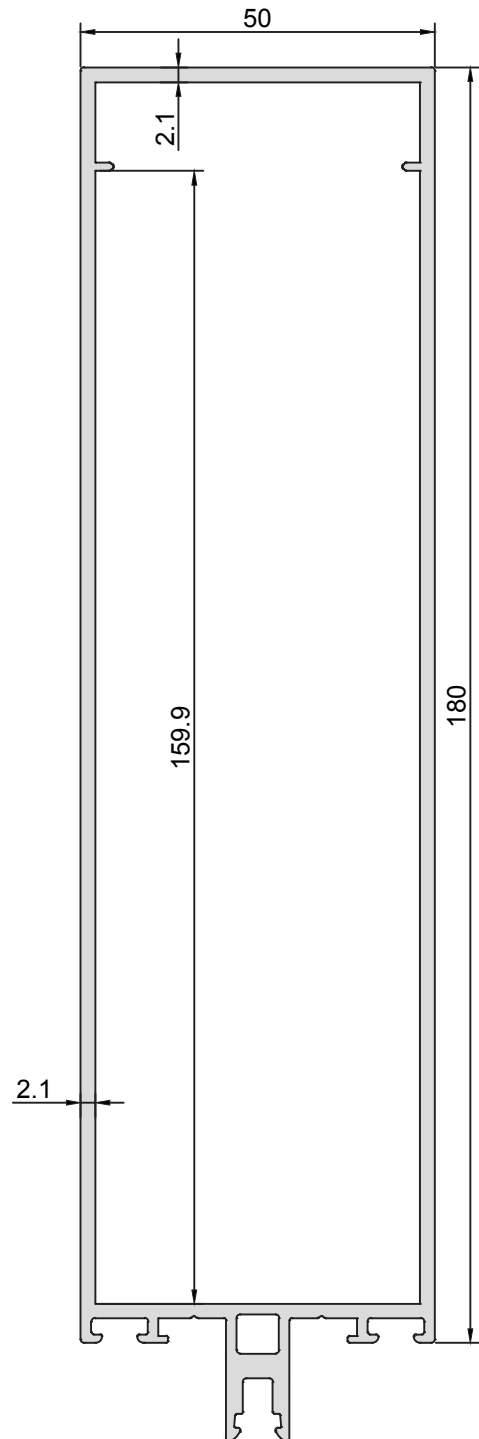

354904

Kg: 3230 gr/m
Ix: 634,4 cm⁴
Iy: 53,27 cm⁴

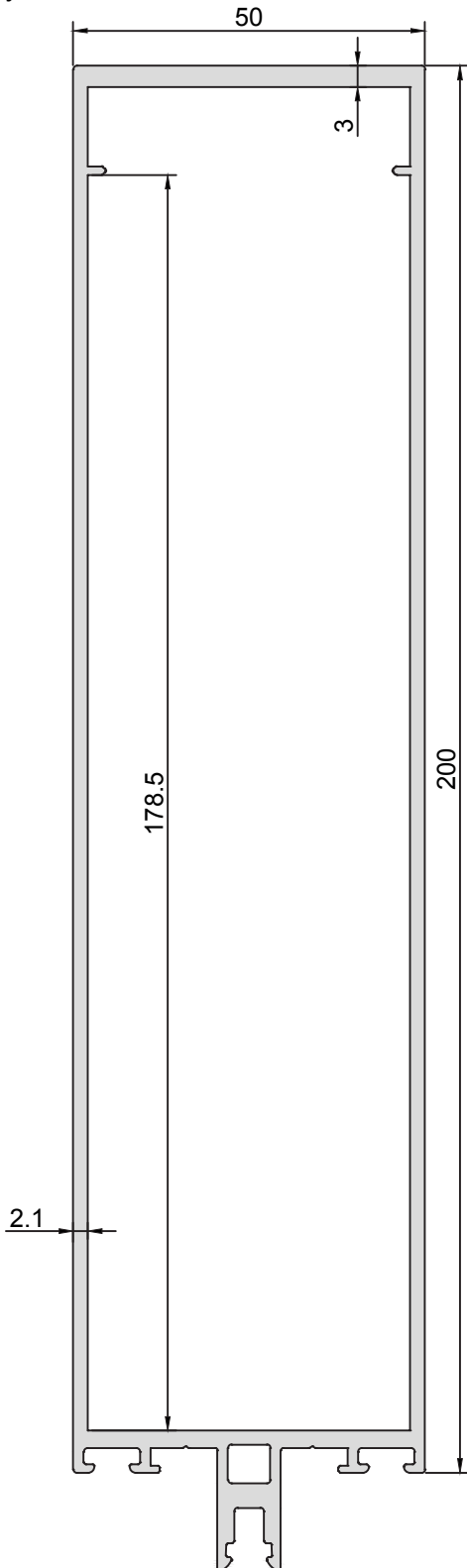

354905

Kg: 3230 gr/m
Ix: 634,4 cm⁴
Iy: 53,27 cm⁴

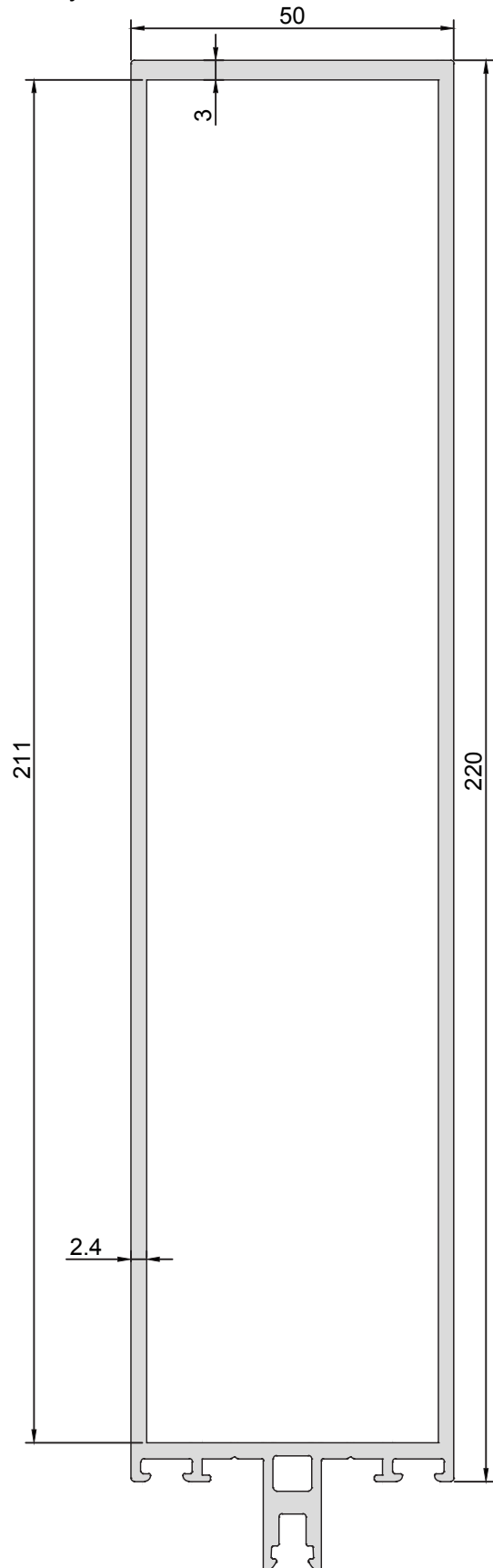

354907

Kg: 1053 gr/m
Ix: 23,03 cm⁴
Iy: 6,17 cm⁴

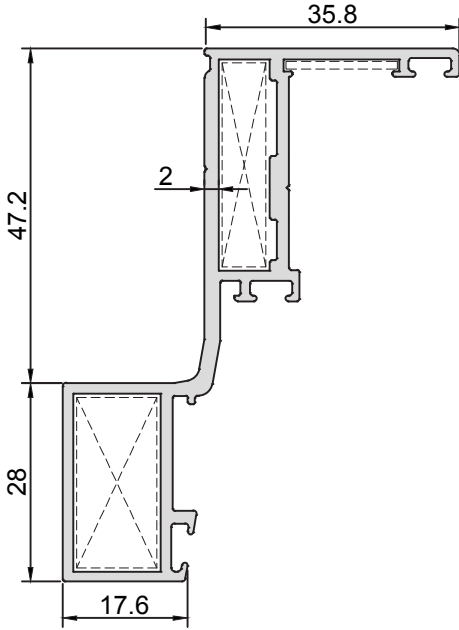

354908

Kg: 1218 gr/m
Ix: 20,40 cm⁴
Iy: 5,90 cm⁴

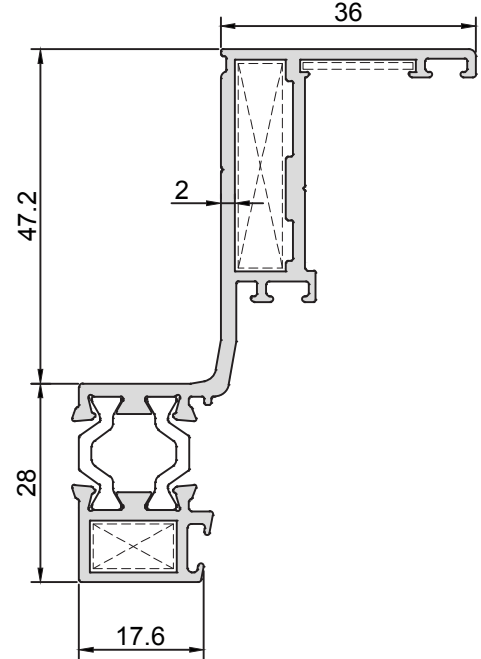

354909

Kg: 1239 gr/m
Ix: 23,33 cm⁴
Iy: 6,14 cm⁴

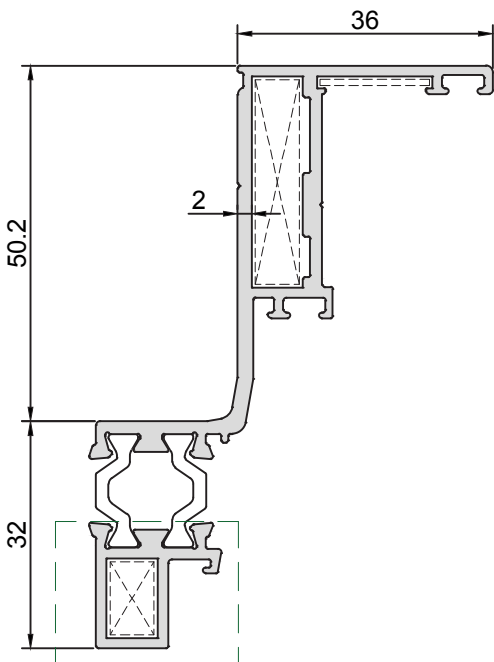

354910

Kg: 1255 gr/m
Ix: 24,38 cm⁴
Iy: 6,25 cm⁴

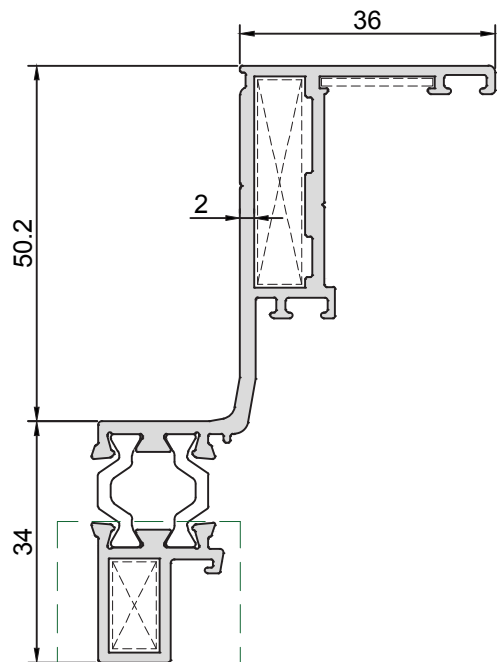

 Ana renk farketmeksizin siyah renk olmalı

 Ana renk farketmeksizin siyah renk olmalı

354911

Kg: 1425 gr/m
Ix: 39,53 cm⁴
Iy: 6,43 cm⁴

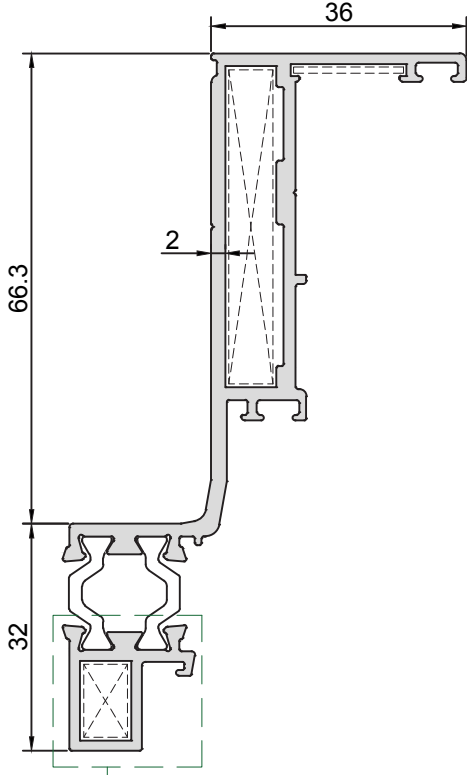

Ana renk farketmeksizin
siyah renk olmalı

354912

Kg: 1441 gr/m
Ix: 40,94 cm⁴
Iy: 6,55 cm⁴

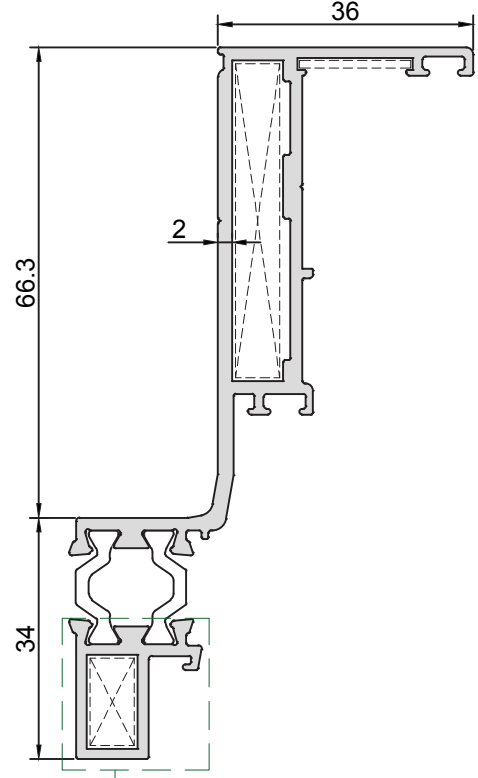

Ana renk farketmeksizin
siyah renk olmalı

354913

Kg: 909 gr/m
Ix: 9,37 cm⁴
Iy: 3,73 cm⁴

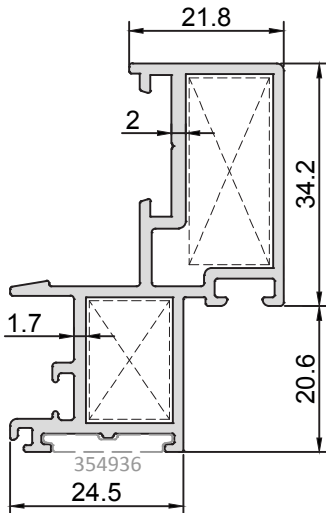

354914

Kg: 1037 gr/m
Ix: 15,85 cm⁴
Iy: 4,27 cm⁴

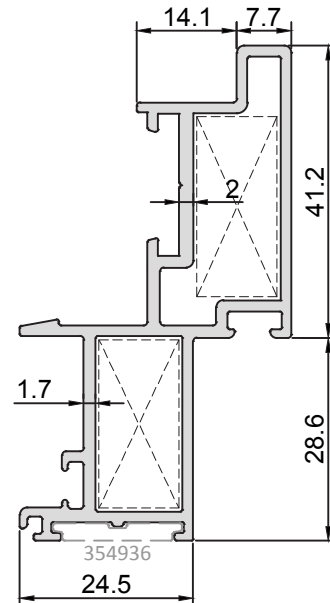

354915

Kg: 1219 gr/m
Ix: 13,80 cm⁴
Iy: 4,15 cm⁴

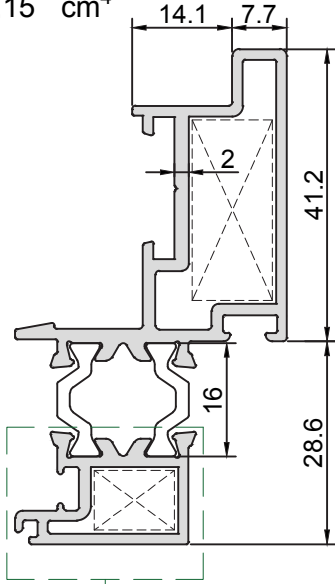

! Ana renk farketmeksizin
20 mikron siyah eloksallı olmalı

354916

Kg: 1255 gr/m
Ix: 30,58 cm⁴
Iy: 5,17 cm⁴

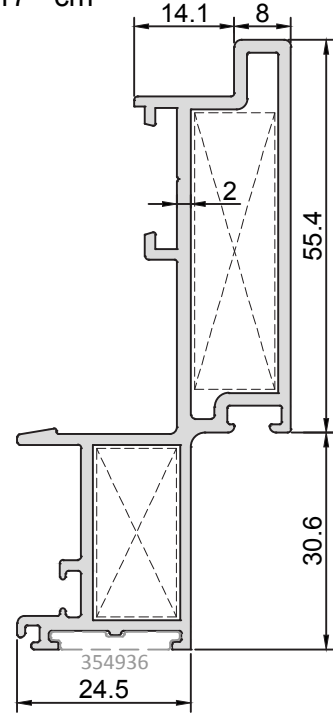

354917

Kg: 1437 gr/m
Ix: 27,3 cm⁴
Iy: 5,01 cm⁴

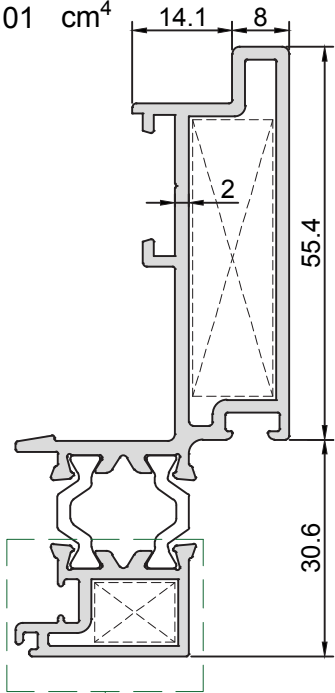

! Ana renk farketmeksizin
20 mikron siyah eloksallı olmalı

354940

Kg: 395 gr/m

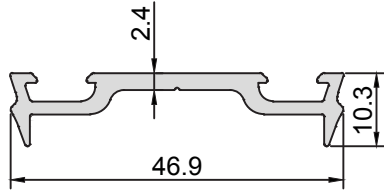

354946

Kg: 283 gr/m

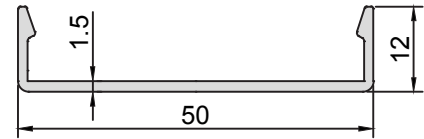

354941

Kg: 496 gr/m

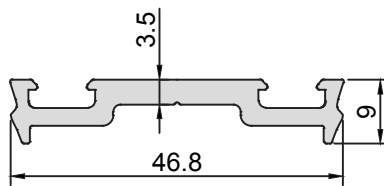

354947

Kg: 308 gr/m

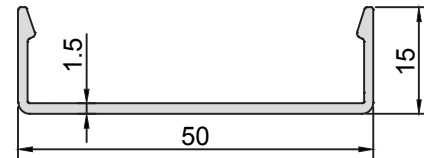

354942

Kg: 413 gr/m

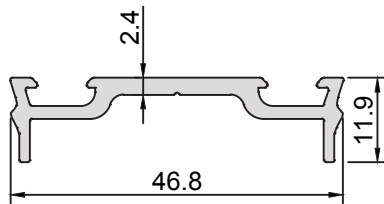

354948

Kg: 343 gr/m

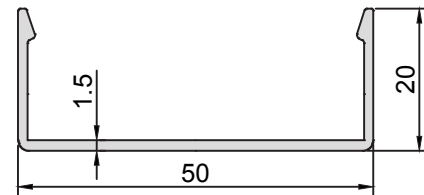

354943

Kg: 494 gr/m

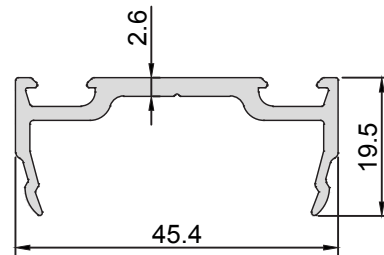

354949

Kg: 403 gr/m

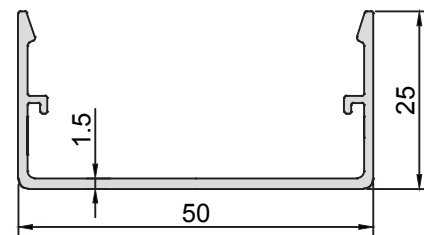

354944

Kg: 183 gr/m

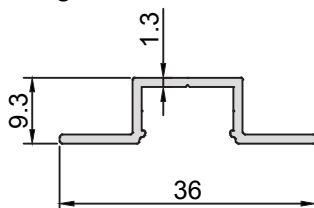

354945

Kg: 43 gr/m

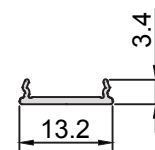

354950

Kg: 455 gr/m

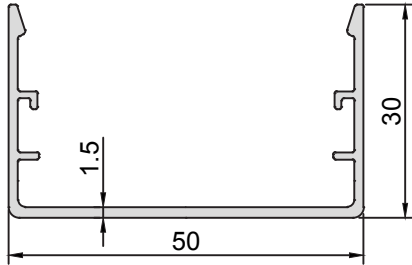

354956

Kg: 262 gr/m

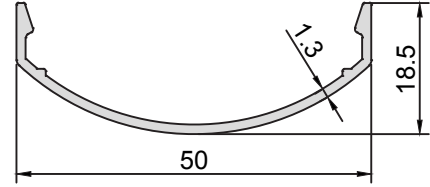

354951

Kg: 745 gr/m

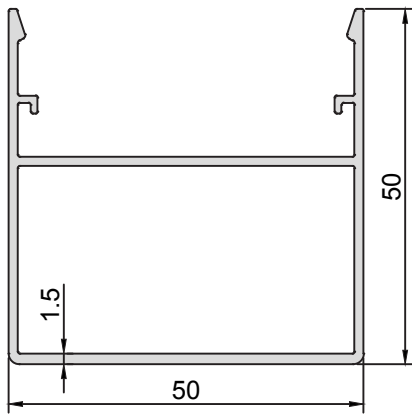

354957

Kg: 397 gr/m

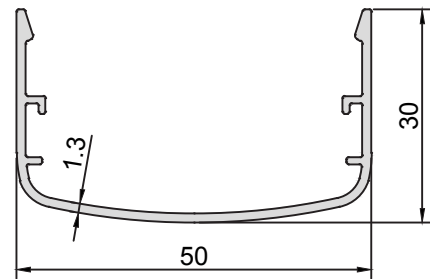

354952

Kg: 954 gr/m

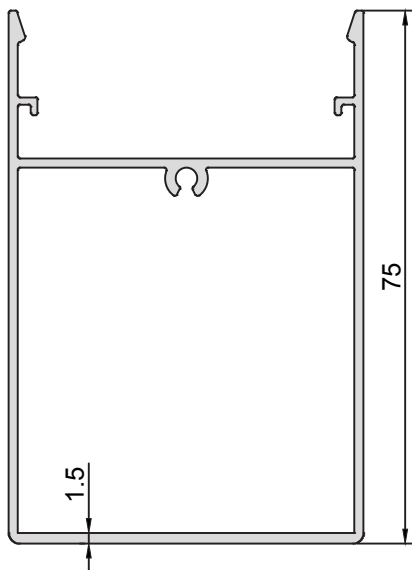

354958

Kg: 611 gr/m

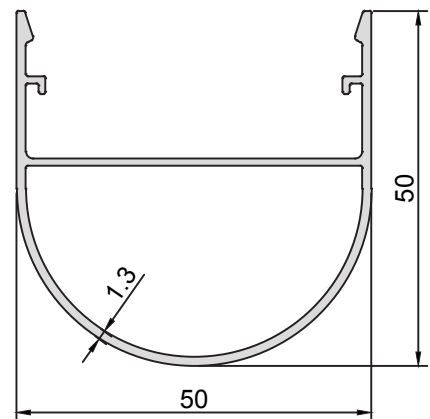

354959

Kg: 753 gr/m

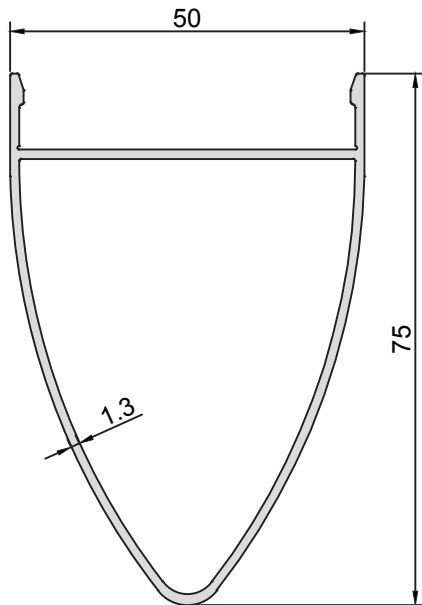

354960

Kg: 879 gr/m

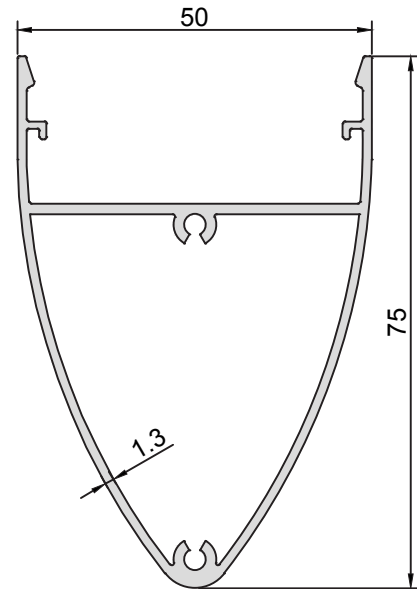

354961

Kg: 1214gr/m

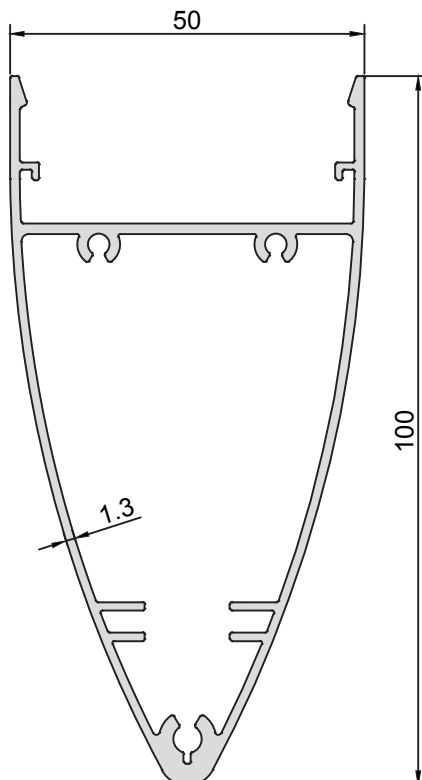

354953

Kg: 1273 gr/m
Ix: 51,45 cm⁴
Iy: 20,74 cm⁴

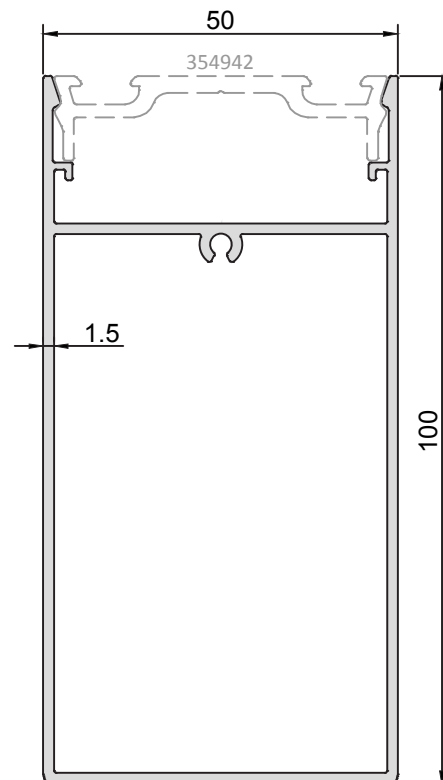

354954

Kg: 2065 gr/m
Ix: 166,2 cm⁴
Iy: 36,07 cm⁴

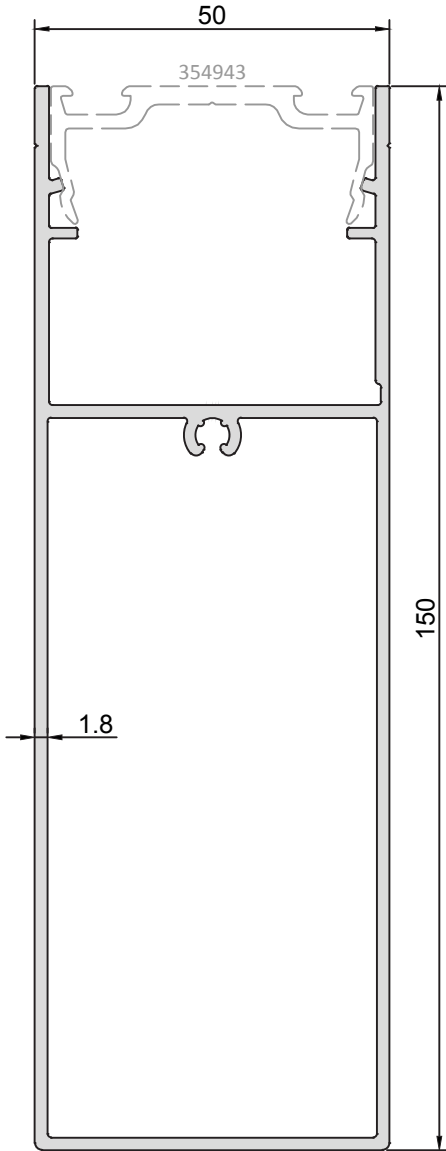

354962

Kg: 1885 gr/m
Ix: 125,4 cm⁴
Iy: 24,90 cm⁴

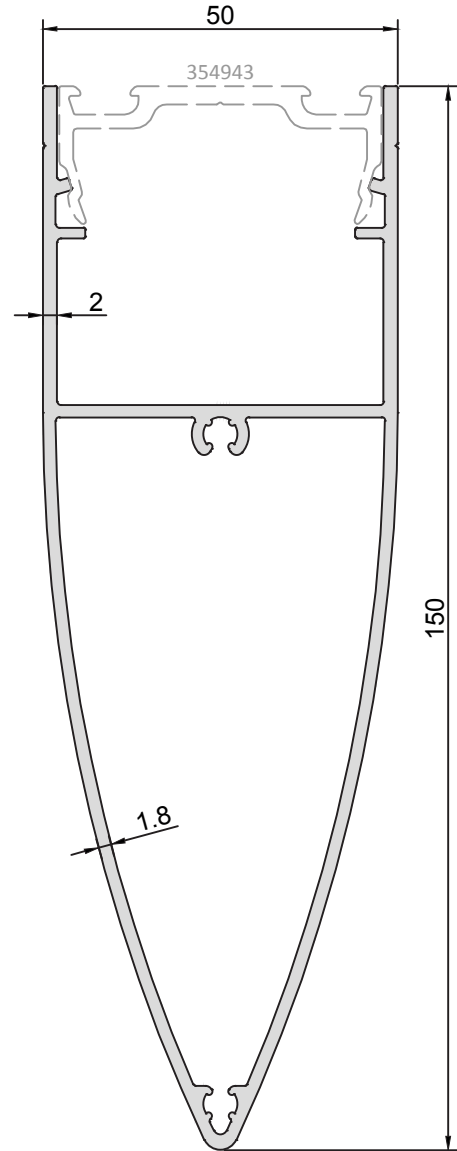

354955

Kg: 3006 gr/m
Ix: 431,5 cm⁴
Iy: 54,38 cm⁴

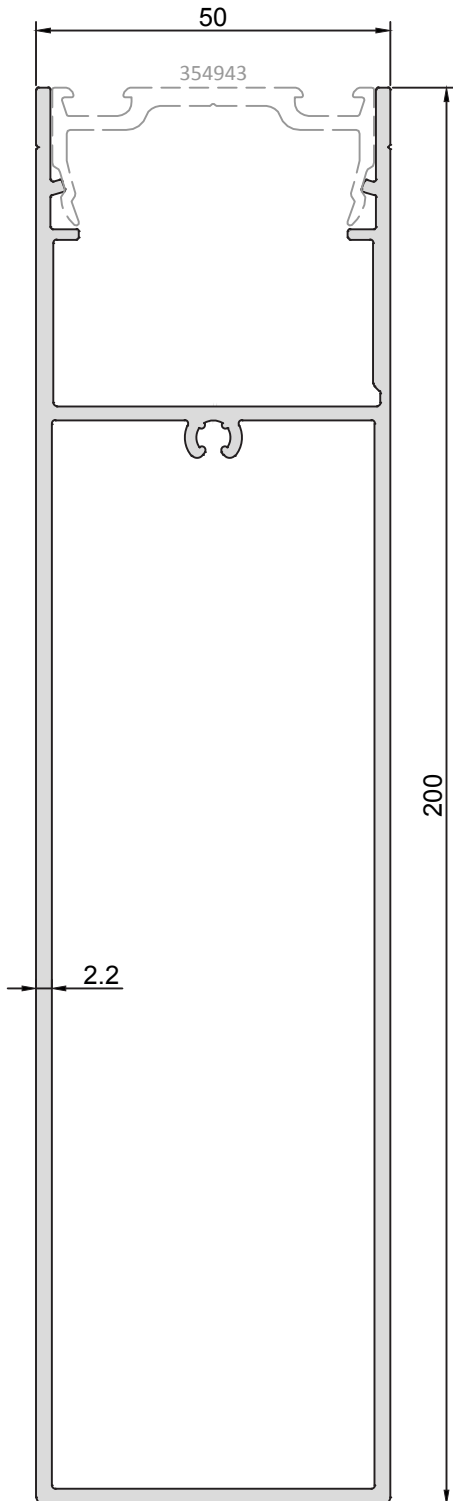

354963

Kg: 2779 gr/m
Ix: 357,4 cm⁴
Iy: 34,28 cm⁴

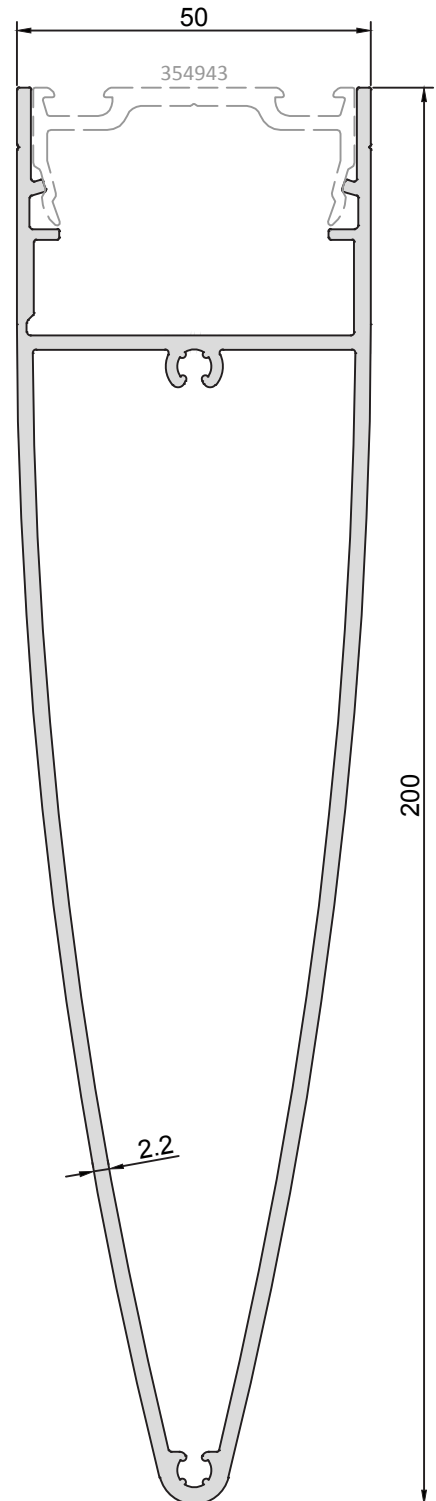

354964

Kg: 1785gr/m

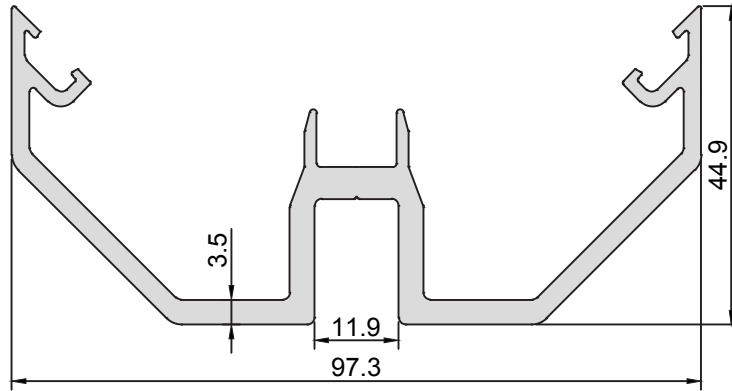

354965

Kg: 384 gr/m

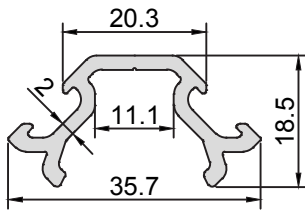

354966

Kg: 251 gr/m

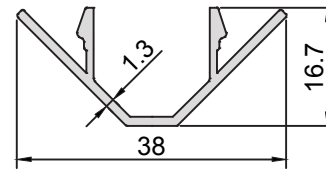

354982

Kg: 329 gr/m

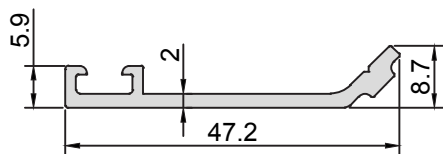

354967

Kg: 524 gr/m

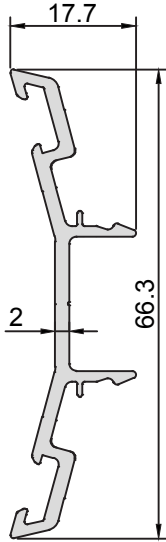

354969

Kg: 614 gr/m

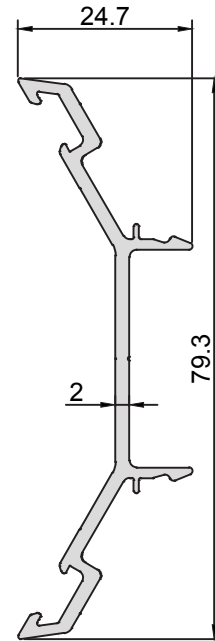

354968

Kg: 562 gr/m

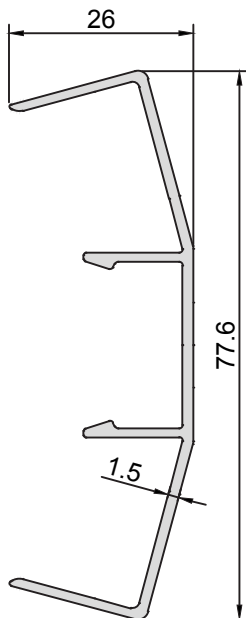

354970

Kg: 674 gr/m

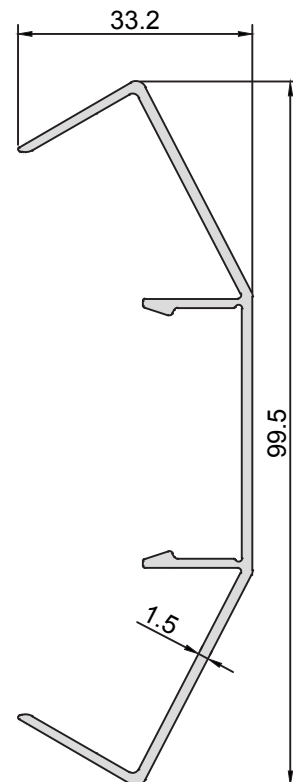

354918

Kg: 437 gr/m

! Ana renk farketmeksizin 20 mikron siyah eloksallı olmalı

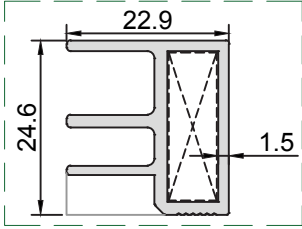

354919

Kg: 485 gr/m

! Ana renk farketmeksizin 20 mikron siyah eloksallı olmalı

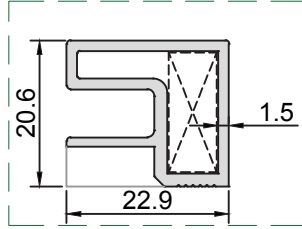

354920

Kg: 468 gr/m

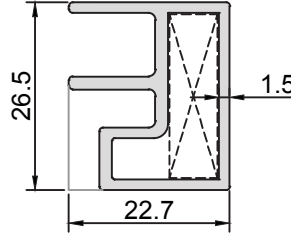

354921

Kg: 416 gr/m

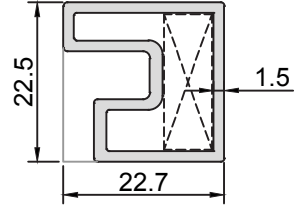

354922

Kg: 294 gr/m

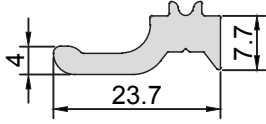

354923

Kg: 319 gr/m

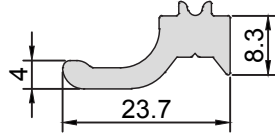

354924

Kg: 332 gr/m

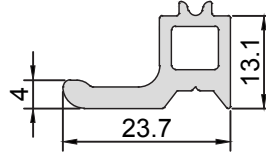

354925

Kg: 354 gr/m

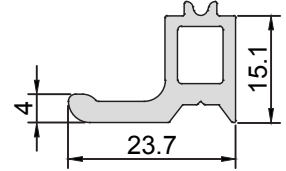

354926

Kg: 270 gr/m

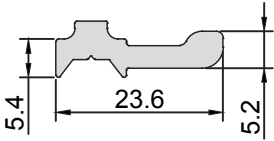

354927

Kg: 281 gr/m

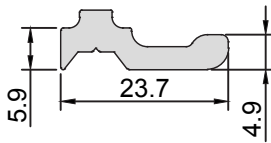

354928

Kg: 343 gr/m

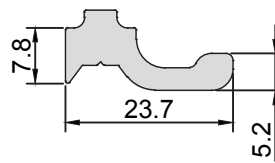

354929

Kg: 340 gr/m

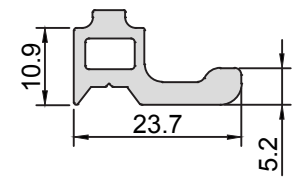

354930

Kg: 277 gr/m

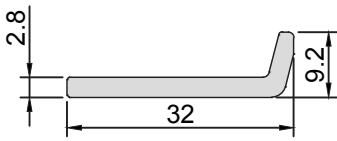

354931

Kg: 308 gr/m

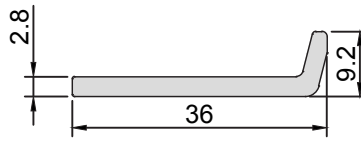

354932

Kg: 338 gr/m

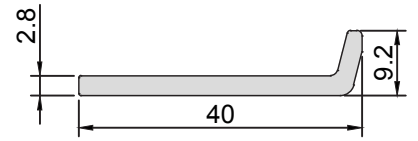

354933

Kg: 368 gr/m

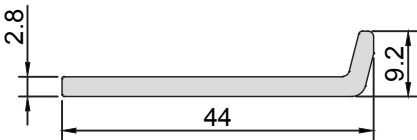

354934

Kg: 482 gr/m

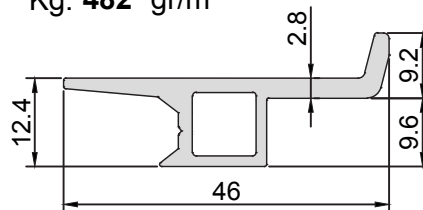

354972

Kg: 98 gr/m

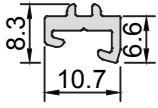

354973

Kg: 105 gr/m

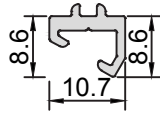

354974

Kg: 112 gr/m

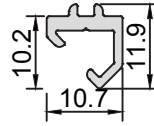

354975

Kg: 96 gr/m

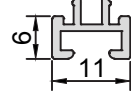

354976

Kg: 151 gr/m

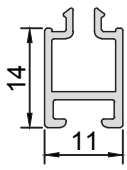

354977

Kg: 179 gr/m

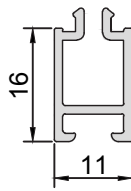

354978

Kg: 192 gr/m

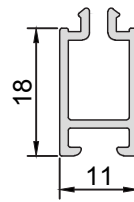

354979

Kg: 207 gr/m

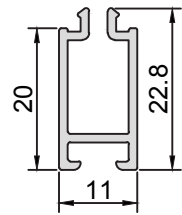

354980

Kg: 218 gr/m

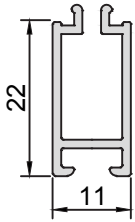

354971

Kg: 234 gr/m

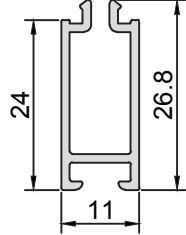

354981

Kg: 270 gr/m

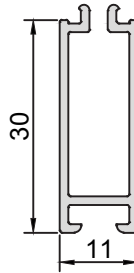

354983

Kg: 96 gr/m

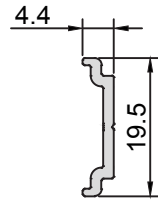

354938

Kg: 112 gr/m

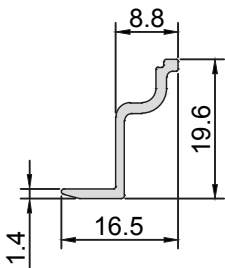

354937

Kg: 078 gr/m

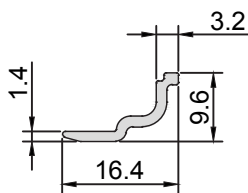

354935

Kg: 240 gr/m



354936

Kg: 109 gr/m



354984

Kg: 3864 gr/m
Ix: 744,2 cm⁴
Iy: 45,76 cm⁴

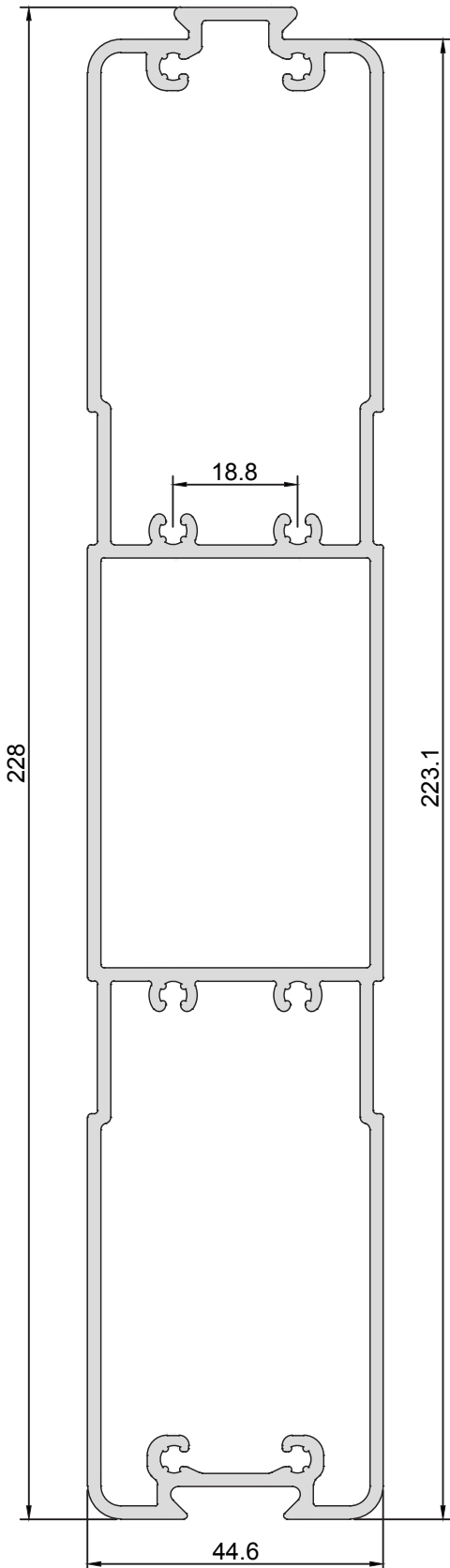

354985

Kg: 3533 gr/m
Ix: 4,10 cm⁴
Iy: 290,5 cm⁴

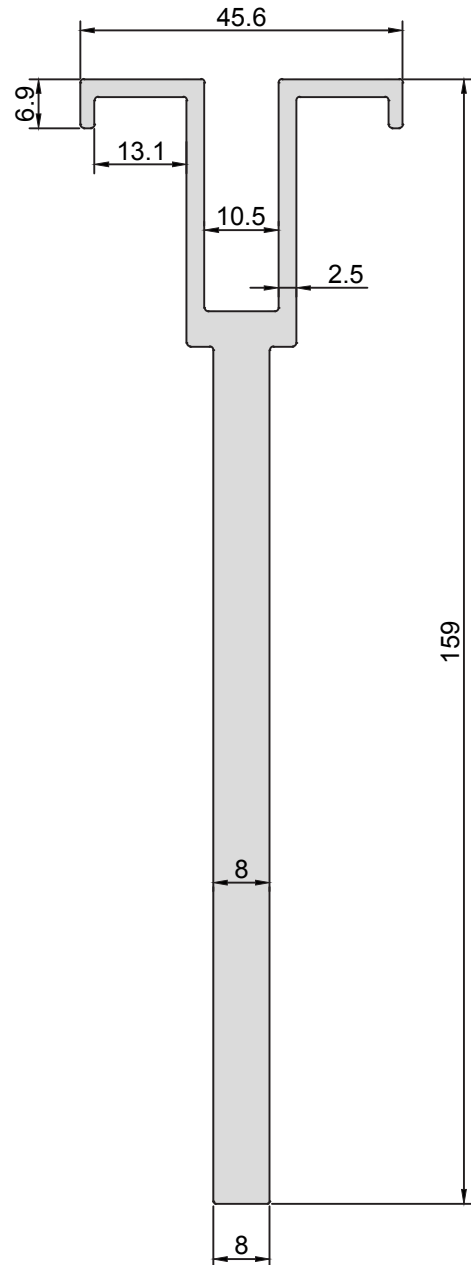

354986

Kg: 1040gr/m

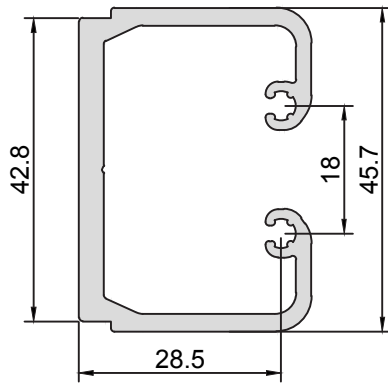

354978

Kg: 947 gr/m

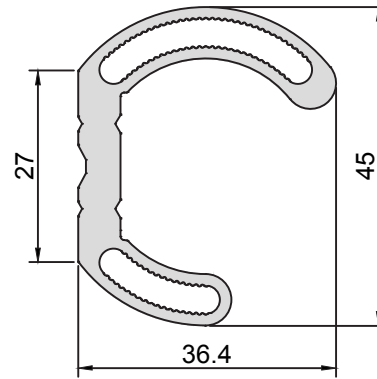

354988

Kg: 1974gr/m

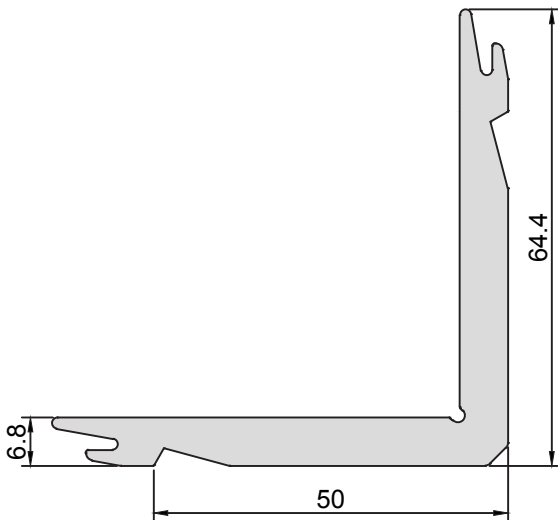

354989

Kg: 2366gr/m

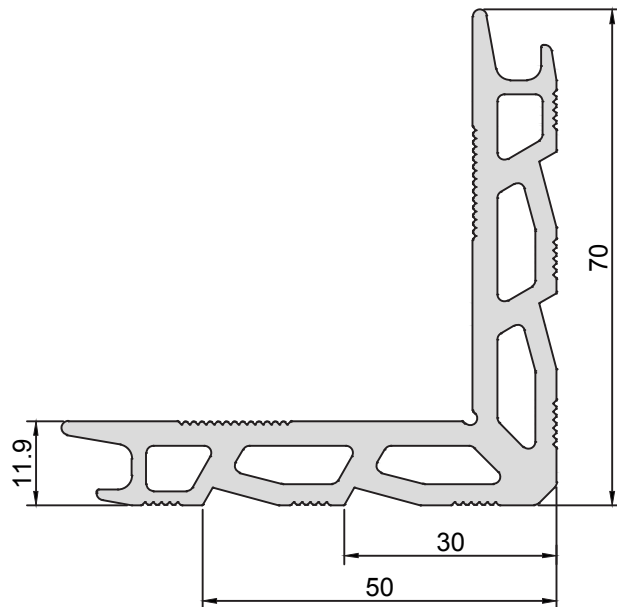









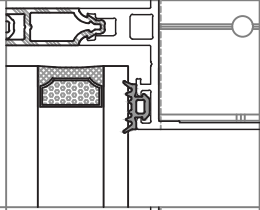

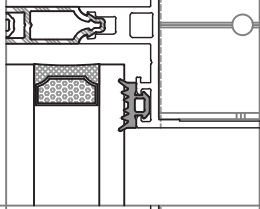

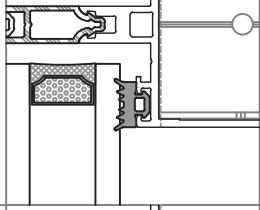

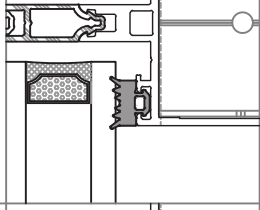

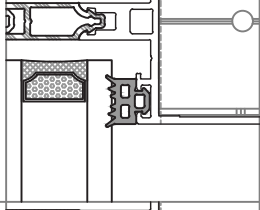

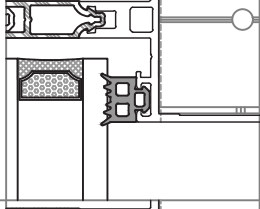

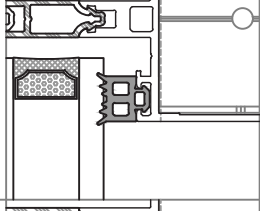

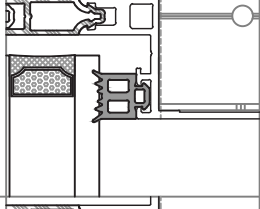

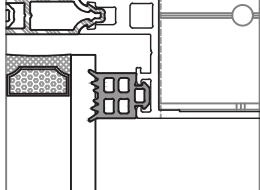

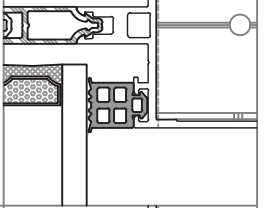
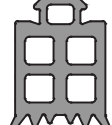
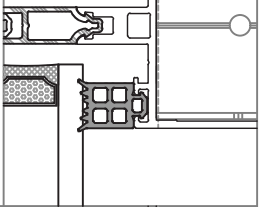

ÜRÜN KODU PRODUCT CODE	ÜRÜN ADI PRODUCT NAME	
350621	KÖŞE TAKOZU - 29,4 mm / CORNER CLEAT	
350622	KÖŞE TAKOZU - 11 mm / CORNER CLEAT	
350623	KÖŞE TAKOZU - 13 mm / CORNER CLEAT	
350624	KÖŞE TAKOZU - 44,9 mm / CORNER CLEAT	
350625	KÖŞE TAKOZU - 21 mm / CORNER CLEAT	
350626	KÖŞE TAKOZU - 17 mm / CORNER CLEAT	
350627	KÖŞE TAKOZU - 23 mm / CORNER CLEAT	
350628	KÖŞE TAKOZU - 19 mm / CORNER CLEAT	
350629	KÖŞE TAKOZU - 24,7 mm / CORNER CLEAT	
350630	KÖŞE TAKOZU - 7 mm / CORNER CLEAT	
350631	KÖŞE TAKOZU - 26,9 mm / CORNER CLEAT	
350632	KÖŞE TAKOZU - 17,5 mm / CORNER CLEAT	
350635	KÖŞE TAKOZU - 26 mm / CORNER CLEAT	
350636	KÖŞE TAKOZU - 9 mm / CORNER CLEAT	
350637	KÖŞE TAKOZU - 24,4 mm / CORNER CLEAT	
350638	KÖŞE TAKOZU - 39,6 mm / CORNER CLEAT	
350639	DİLATASYON BAĞLANTISI - 17,5 mm / DILATATION CONNECTION	
350640	DİLATASYON BAĞLANTISI - 32,5 mm / DILATATION CONNECTION	
350641	DİLATASYON BAĞLANTISI - 52,5 mm / DILATATION CONNECTION	
350642	DİLATASYON BAĞLANTISI - 72,5 mm / DILATATION CONNECTION	
350643	DİLATASYON BAĞLANTISI - 92,5 mm / DILATATION CONNECTION	
350644	DİLATASYON BAĞLANTISI - 91,5 mm / DILATATION CONNECTION	
350645	DİLATASYON BAĞLANTISI - 112 mm / DILATATION CONNECTION	
350646	DİLATASYON BAĞLANTISI - 110 mm / DILATATION CONNECTION	
350647	DİLATASYON BAĞLANTISI - 132 mm / DILATATION CONNECTION	
350648	DİLATASYON BAĞLANTISI - 129,5 mm / DILATATION CONNECTION	
350649	DİLATASYON BAĞLANTISI - 151,5 mm / DILATATION CONNECTION	
350650	DİLATASYON BAĞLANTISI - 149 mm / DILATATION CONNECTION	
350651	DİLATASYON BAĞLANTISI - 171,5 mm / DILATATION CONNECTION	
350652	DİLATASYON BAĞLANTISI - 169 mm / DILATATION CONNECTION	
350653	DİLATASYON BAĞLANTISI - 190 mm / DILATATION CONNECTION	
350656	DİLATASYON BAĞLANTISI - 187 mm / DILATATION CONNECTION	
350657	U BAĞLANTI - 12 mm / U CONNECTION	
350658	U BAĞLANTI - 32 mm / U CONNECTION	
350660	U BAĞLANTI - 42 mm / U CONNECTION	
350661	U BAĞLANTI - 52 mm / U CONNECTION	
350662	U BAĞLANTI - 59,4 mm / U CONNECTION	

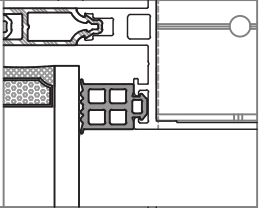
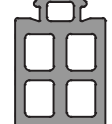
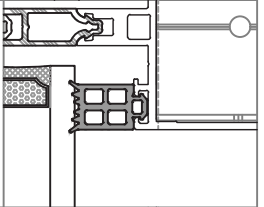

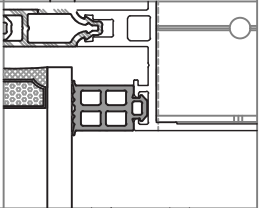

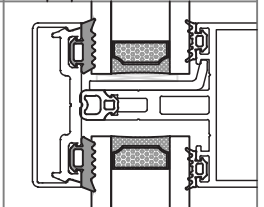
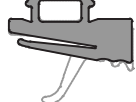
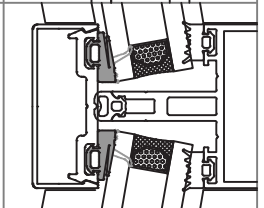

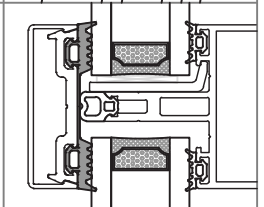

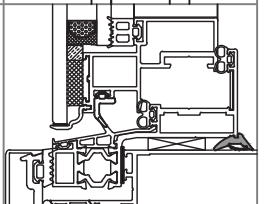

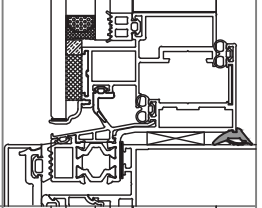

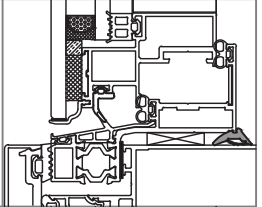

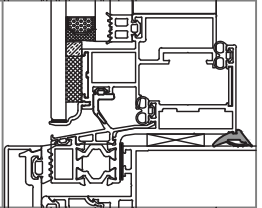

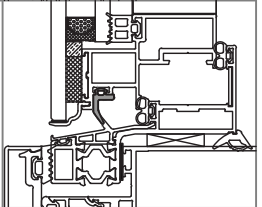
ÜRÜN KODU PRODUCT CODE	ÜRÜN ADI PRODUCT NAME	
350662	U BAĞLANTI - 59,4 mm / U CONNECTION	
350663	U BAĞLANTI - 79,4 mm / U CONNECTION	
350664	U BAĞLANTI - 99,4 mm / U CONNECTION	
350665	U BAĞLANTI - 119,4 mm / U CONNECTION	
350666	U BAĞLANTI - 139,4 mm / U CONNECTION	
350667	U BAĞLANTI - 159,4 mm / U CONNECTION	
350668	U BAĞLANTI - 178 mm / U CONNECTION	
350669	U BAĞLANTI - 210 mm / U CONNECTION	
350675	CAM ALTI DESTEK PARÇASI / GLAZING SUPPORT	
350676	CAM ALTI DESTEK PARÇASI / GLAZING SUPPORT	
350677	CAM ALTI DESTEK PARÇASI / GLAZING SUPPORT	
350678	CAM ALTI DESTEK PARÇASI / GLAZING SUPPORT	
350679	CAM ALTI DESTEK PARÇASI / GLAZING SUPPORT	
350685	KANAT İÇİN CAM ALTI DESTEK PARÇASI / GLAZING SUPPORT FOR VENT	
350686	KANAT İÇİN CAM ALTI DESTEK PARÇASI / GLAZING SUPPORT FOR VENT	
350687	CAM ARASI KİLİTLEME PARÇASI / FOURSIDE LOCKING PIECE	
350688	CAM ARASI KİLİTLEME PARÇASI / FOURSIDE LOCKING PIECE	
350689	CAM ARASI KİLİTLEME PARÇASI / FOURSIDE LOCKING PIECE	
350690	CAM ARASI KİLİTLEME PARÇASI / FOURSIDE LOCKING PIECE	
350691	CAM ARASI KİLİTLEME PARÇASI / FOURSIDE LOCKING PIECE	
350692	CAM ARASI KİLİTLEME PARÇASI / FOURSIDE LOCKING PIECE	
350694	CAM ARASI KİLİTLEME PARÇASI / FOURSIDE LOCKING PIECE	
350695	CAM ARASI KİLİTLEME PARÇASI / FOURSIDE LOCKING PIECE	
350696	GÜNEŞ KIRICI TAŞIYICI APARATI / CARRIER APPARATUS FOR SUNBREAKER	
350697	İÇ BİNİ FITİLİ 2mm / INNER STEP GASKET 2mm	
350698	İÇ BİNİ FITİLİ 3mm / INNER STEP GASKET 3mm	
350699	İÇ BİNİ FITİLİ 4mm / INNER STEP GASKET 4mm	
350700	İÇ BİNİ FITİLİ 5mm / INNER STEP GASKET 5mm	
350701	İÇ BİNİ FITİLİ 6mm / INNER STEP GASKET 6mm	
350702	İÇ BİNİ FITİLİ 7mm / INNER STEP GASKET 7mm	
350703	İÇ BİNİ FITİLİ 8mm / INNER STEP GASKET 8mm	
350704	İÇ BİNİ FITİLİ 9mm / INNER STEP GASKET 9mm	
350705	İÇ BİNİ FITİLİ 10mm / INNER STEP GASKET 10mm	
350706	İÇ BİNİ FITİLİ 11mm / INNER STEP GASKET 11mm	
350707	İÇ BİNİ FITİLİ 12mm / INNER STEP GASKET 12mm	
350708	İÇ BİNİ FITİLİ 13mm / INNER STEP GASKET 13mm	
350709	İÇ BİNİ FITİLİ 14mm / INNER STEP GASKET 14mm	

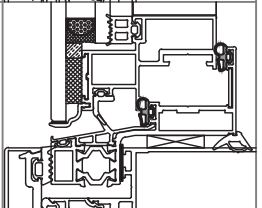

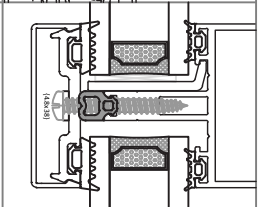

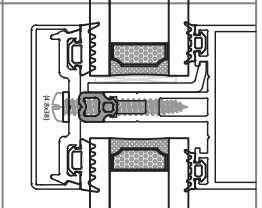

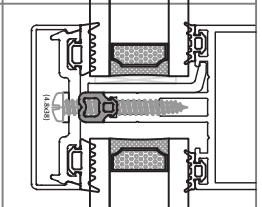

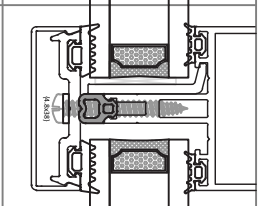

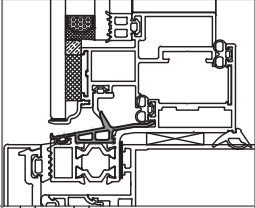

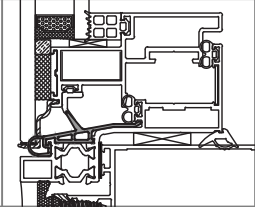
ÜRÜN KODU PRODUCT CODE	ÜRÜN ADI PRODUCT NAME	
350718	İÇ BİNİ FİTİLİ 15mm / INNER STEP GASKET 15mm	
350719	DIŞ BİNİ FİTİLİ / OUTER STEP GASKET	
350720	AÇILI DIŞ CAM FİTİLİ / ANGULAR OUTER STEP GASKET	
350721	YEKPARE DIŞ BİNİ FİTİLİ / ONE PIECE STEP GASKET	
350722	KAMA FİTİLİ 3mm / GLAZING SUPPORT GASKET 3mm	
350723	KAMA FİTİLİ 4mm / GLAZING SUPPORT GASKET 4mm	
350724	KAMA FİTİLİ 5mm / GLAZING SUPPORT GASKET 5mm	
350725	KAMA FİTİLİ 6mm / GLAZING SUPPORT GASKET 6mm	
350726	KANAT DESTEK FİTİLİ / SUPPORT GASKET FOR VENT	
350727	KANAT İÇ BİNİ FİTİLİ / GLAZING SUPPORT FOR VENT	
350728	TAŞIYICI ÖN FİTİL 3mm / MULLION FRONT GASKET 3mm	
350729	TAŞIYICI ÖN FİTİL 4mm / MULLION FRONT GASKET 4mm	
350746	TAŞIYICI ÖN FİTİL 5mm / MULLION FRONT GASKET 5mm	
350747	TAŞIYICI ÖN FİTİL 7mm / MULLION FRONT GASKET 7mm	
350748	KANAT ÇARŞAF FİTİLİ / SHEET GASKET FOR VENT	
350749	KANAT ÇARŞAF FİTİLİ / SHEET GASKET FOR VENT	
350750	KANAT ÇARŞAF FİTİLİ / SHEET GASKET FOR VENT	
350751	KANAT ÇARŞAF FİTİLİ / SHEET GASKET FOR VENT	
350752	POLİETİLEN DERZ KAPATMA FİTİLİ / POLYETHELENE SEAM GASKET	
350753	İÇ MEKAN DERZ KAPATMA FİTİLİ / INSIDE SEAM GASKET	
350754	SİLİKON DERZ KAPATMA FİTİLİ / SILICONE SEAM GASKET	
350755	VULKANİZE KÖŞE PARÇASI / VULCANISED CORNER PIECE	
350756	VULKANİZE KÖŞE PARÇASI / VULCANISED CORNER PIECE	
350757	VULKANİZE KÖŞE PARÇASI / VULCANISED CORNER PIECE	
350758	YATAY KAYIT CONTASI 20mm / TRANSOM CONNECTION PLUGS 20mm	
350759	YATAY KAYIT CONTASI 40mm / TRANSOM CONNECTION PLUGS 40mm	
350760	YATAY KAYIT CONTASI 60mm / TRANSOM CONNECTION PLUGS 60mm	
350761	YATAY KAYIT CONTASI 80mm / TRANSOM CONNECTION PLUGS 80mm	
350762	YATAY KAYIT CONTASI 100mm / TRANSOM CONNECTION PLUGS 100mm	
350763	YATAY KAYIT CONTASI 120mm / TRANSOM CONNECTION PLUGS 120mm	
350764	YATAY KAYIT CONTASI 140mm / TRANSOM CONNECTION PLUGS 140mm	
350765	YATAY KAYIT CONTASI 160mm / TRANSOM CONNECTION PLUGS 160mm	
350766	YATAY KAYIT CONTASI 180mm / TRANSOM CONNECTION PLUGS 180mm	
350767	YATAY KAYIT CONTASI 200mm / TRANSOM CONNECTION PLUGS 200mm	
350768	YATAY KAYIT CONTASI 220mm / TRANSOM CONNECTION PLUGS 220mm	
350769	TAŞIYICI ÖN İZOLASYON (PVC) - 4mm / MULLION OR TRANSOM FRONT ISOLATOR (PVC) - 4mm	
350770	TAŞIYICI ÖN İZOLASYON (PVC) - 8mm / MULLION OR TRANSOM FRONT ISOLATOR (PVC) - 8mm	

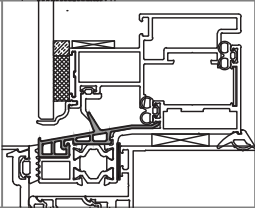
ÜRÜN KODU PRODUCT CODE	ÜRÜN ADI PRODUCT NAME	
350771	TAŞIYICI ÖN İZOLASYON (PVC) - 12mm / MULLION OR TRANSOM FRONT ISOLATOR (PVC) - 12mm	
350772	TAŞIYICI ÖN İZOLASYON (PVC) - 16mm / MULLION OR TRANSOM FRONT ISOLATOR (PVC) - 16mm	
350773	TAŞIYICI ÖN İZOLASYON (PVC) - 20mm / MULLION OR TRANSOM FRONT ISOLATOR (PVC) - 20mm	
350774	TAŞIYICI ÖN İZOLASYON (PVC) - 24mm / MULLION OR TRANSOM FRONT ISOLATOR (PVC) - 24mm	
350775	TAŞIYICI ÖN İZOLASYON (PVC) - 28mm / MULLION OR TRANSOM FRONT ISOLATOR (PVC) - 28mm	
350776	KÖŞE ÇAVUŞU 16 x 1,5mm / CORNER ALIGNMENT	
350777	DİLATASYON TAPASI / DILATATION PLUG	
350778	KONDENS YOLU İÇİN BAĞLANTI PARÇASI / CONNECTION PIECE FOR CONDENSATION LINE	
350779	ÇÖRTEN / WATERSPOUT	
350780	ISICAM KÖŞE BİRLEŞTİRME PARÇASI / CORNER CONNECTION PIECE FOR DOUBLE GLAZING	
350781	CAM ARASI KİTLEME HAVUZU / LOCKING HOLE FOR DOUBLE GLAZING	
350782	MAKAS ALTI BESLEME TAKOZU / FRICTION STAY REINFORCEMENT PLUG	
350783	ISICAM KÖŞE BİRLEŞTİRME PARÇASI / CORNER CONNECTION PIECE FOR DOUBLE GLAZING	
350784	YATAY BAKLALI SABİT ANKRAJ / HORIZONTAL MOVABLE FIXED ANCHORAGE	
350785	YATAY BAKLALI SABİT ANKRAJ / HORIZONTAL MOVABLE FIXED ANCHORAGE	
350786	YATAY BAKLALI SABİT ANKRAJ / HORIZONTAL MOVABLE FIXED ANCHORAGE	
350787	YATAY BAKLALI SABİT ANKRAJ / HORIZONTAL MOVABLE FIXED ANCHORAGE	
350788	YATAY BAKLALI SABİT ANKRAJ / HORIZONTAL MOVABLE FIXED ANCHORAGE	
350789	DÜŞEY BAKLALI SABİT ANKRAJ / VERTICAL MOVABLE FIXED ANCHORAGE	
350790	DÜŞEY BAKLALI SABİT ANKRAJ / VERTICAL MOVABLE FIXED ANCHORAGE	
350791	DÜŞEY BAKLALI SABİT ANKRAJ / VERTICAL MOVABLE FIXED ANCHORAGE	
350792	DÜŞEY BAKLALI SABİT ANKRAJ / VERTICAL MOVABLE FIXED ANCHORAGE	
350793	DÜŞEY BAKLALI SABİT ANKRAJ / VERTICAL MOVABLE FIXED ANCHORAGE	
350794	METRİK PERÇİN VE VİDA SETİ / METRIC PIN AND SCREW KIT	
350795	10" - CEPHE MAKASI / FRICTION STAY - 10"	
350796	12" - CEPHE MAKASI / FRICTION STAY - 12"	
350797	14" - CEPHE MAKASI / FRICTION STAY - 14"	
350798	16" - CEPHE MAKASI / FRICTION STAY - 16"	
350799	18" - CEPHE MAKASI / FRICTION STAY - 18"	
350800	20" - CEPHE MAKASI / FRICTION STAY - 20"	
350801	22" - CEPHE MAKASI / FRICTION STAY - 22"	
350802	24" - CEPHE MAKASI / FRICTION STAY - 24"	
350803	26" - CEPHE MAKASI / FRICTION STAY - 26"	
350804	28" - CEPHE MAKASI / FRICTION STAY - 28"	
350805	CEPHE KOLU / FACADE HANDLE	
350806	CEPHE KOLU BAĞLANTISI - 14,5mm / FACADE HANDLE CONNECTION 14,5mm	
350807	CEPHE KOLU BAĞLANTISI - 17,5mm / FACADE HANDLE CONNECTION 17,5mm	

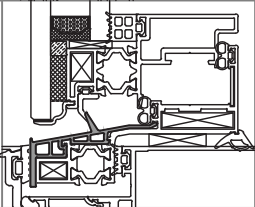
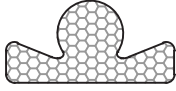
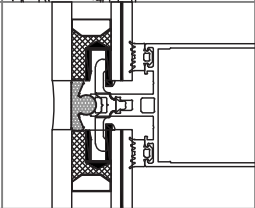
AKSESUAR KODU VE ÜRÜN BİLGİLERİ / ACCESSORY CODE AND PRODUCT DESCRIPTION	ÇİZİM / DRAWING	TAKILMA BÖLGESİ / APPLICATION AREA
<p>350697 İÇ BİNİ FİTİLİ 2 mm / INNER STEP GASKET 2 mm BİRİM AĞIRLIK / UNIT WEIGHT: 39 g/m KOLİ MİKTARI / PACKAGE QUANTITY: 382 m</p>		
<p>350698 İÇ BİNİ FİTİLİ 3 mm / INNER STEP GASKET 3 mm BİRİM AĞIRLIK / UNIT WEIGHT: 52 g/m KOLİ MİKTARI / PACKAGE QUANTITY: 288 m</p>		
<p>350699 İÇ BİNİ FİTİLİ 4 mm / INNER STEP GASKET 4 mm BİRİM AĞIRLIK / UNIT WEIGHT: 68 g/m KOLİ MİKTARI / PACKAGE QUANTITY: 220 m</p>		
<p>350700 İÇ BİNİ FİTİLİ 5 mm / INNER STEP GASKET 5 mm BİRİM AĞIRLIK / UNIT WEIGHT: 82 g/m KOLİ MİKTARI / PACKAGE QUANTITY: 183 m</p>		
<p>350701 İÇ BİNİ FİTİLİ 6 mm / INNER STEP GASKET 6 mm BİRİM AĞIRLIK / UNIT WEIGHT: 86 g/m KOLİ MİKTARI / PACKAGE QUANTITY: 174 m</p>		
<p>350702 İÇ BİNİ FİTİLİ 7 mm / INNER STEP GASKET 7 mm BİRİM AĞIRLIK / UNIT WEIGHT: 91 g/m KOLİ MİKTARI / PACKAGE QUANTITY: 166 m</p>		
<p>350703 İÇ BİNİ FİTİLİ 8 mm / INNER STEP GASKET 8 mm BİRİM AĞIRLIK / UNIT WEIGHT: 98 g/m KOLİ MİKTARI / PACKAGE QUANTITY: 153 m</p>		
<p>350704 İÇ BİNİ FİTİLİ 9 mm / INNER STEP GASKET 9 mm BİRİM AĞIRLIK / UNIT WEIGHT: 105 g/m KOLİ MİKTARI / PACKAGE QUANTITY: 143 m</p>		
<p>350705 İÇ BİNİ FİTİLİ 10 mm / INNER STEP GASKET 10 mm BİRİM AĞIRLIK / UNIT WEIGHT: 115 g/m KOLİ MİKTARI / PACKAGE QUANTITY: 130 m</p>		

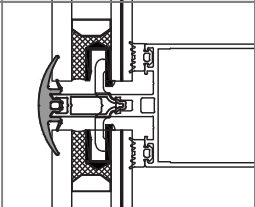
AKSESUAR KODU VE ÜRÜN BİLGİLERİ / ACCESSORY CODE AND PRODUCT DESCRIPTION	ÇİZİM / DRAWING	TAKILMA BÖLGESİ / APPLICATION AREA
<p>350706 İÇ BİNİ FİTİLİ 11 mm / INNER STEP GASKET 11 mm BİRİM AĞIRLIK / UNIT WEIGHT: 120 g/m KOLİ MİKTARI / PACKAGE QUANTITY: 125 m</p>		
<p>350707 İÇ BİNİ FİTİLİ 12 mm / INNER STEP GASKET 12 mm BİRİM AĞIRLIK / UNIT WEIGHT: 126 g/m KOLİ MİKTARI / PACKAGE QUANTITY: 120 m</p>		
<p>350708 İÇ BİNİ FİTİLİ 13 mm / INNER STEP GASKET 13 mm BİRİM AĞIRLIK / UNIT WEIGHT: 131 g/m KOLİ MİKTARI / PACKAGE QUANTITY: 115 m</p>		
<p>350709 İÇ BİNİ FİTİLİ 14 mm / INNER STEP GASKET 14 mm BİRİM AĞIRLIK / UNIT WEIGHT: 137 g/m KOLİ MİKTARI / PACKAGE QUANTITY: 110 m</p>		
<p>350718 İÇ BİNİ FİTİLİ 15 mm / INNER STEP GASKET 15 mm BİRİM AĞIRLIK / UNIT WEIGHT: 143 g/m KOLİ MİKTARI / PACKAGE QUANTITY: 105 m</p>		
<p>350719 DIŞ BİNİ FİTİLİ 4 mm / OUTER STEP GASKET 4 mm BİRİM AĞIRLIK / UNIT WEIGHT: 88 g/m KOLİ MİKTARI / PACKAGE QUANTITY: 170 m</p>		
<p>350720 AÇILI DIŞ CAM FİTİLİ / ANGULAR OUTER STEP GASKET BİRİM AĞIRLIK / UNIT WEIGHT: 91 g/m KOLİ MİKTARI / PACKAGE QUANTITY: 165 m</p>		
<p>350721 YEKPARE DIŞ BİNİ FİTİLİ / ONE PIECE STEP GASKET BİRİM AĞIRLIK / UNIT WEIGHT: 124 g/m KOLİ MİKTARI / PACKAGE QUANTITY: 121 m</p>		
<p>350722 KAMA FİTİLİ 3 mm / GLAZING SUPPORT GASKET 3 mm BİRİM AĞIRLIK / UNIT WEIGHT: 41 g/m KOLİ MİKTARI / PACKAGE QUANTITY: 365 m</p>		

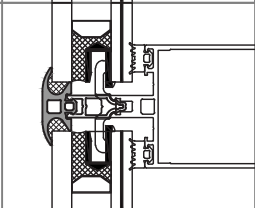
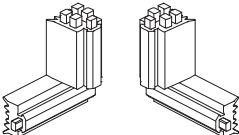
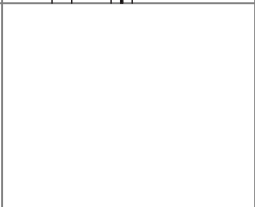
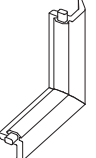
AKSESUAR KODU VE ÜRÜN BİLGİLERİ / ACCESSORY CODE AND PRODUCT DESCRIPTION	ÇİZİM / DRAWING	TAKILMA BÖLGESİ / APPLICATION AREA
<p>350723 KAMA FİTİLİ 4 mm / GLAZING SUPPORT GASKET 4 mm BİRİM AĞIRLIK / UNIT WEIGHT: 54 g/m KOLİ MİKTARI / PACKAGE QUANTITY: 280 m</p>		
<p>350724 KAMA FİTİLİ 5 mm / GLAZING SUPPORT GASKET 5 mm BİRİM AĞIRLIK / UNIT WEIGHT: 67 g/m KOLİ MİKTARI / PACKAGE QUANTITY: 224 m</p>		
<p>350725 KAMA FİTİLİ 6 mm / GLAZING SUPPORT GASKET 6 mm BİRİM AĞIRLIK / UNIT WEIGHT: 89 g/m KOLİ MİKTARI / PACKAGE QUANTITY: 168 m</p>		
<p>350726 KANAT DESTEK FİTİLİ / SUPPORT GASKET FOR VENT BİRİM AĞIRLIK / UNIT WEIGHT: 54 g/m KOLİ MİKTARI / PACKAGE QUANTITY: 275 m</p>		
<p>350727 KANAT İÇ BİNİ FİTİLİ / INNER STEP GASKET FOR VENT BİRİM AĞIRLIK / UNIT WEIGHT: 40 g/m KOLİ MİKTARI / PACKAGE QUANTITY: 370 m</p>		
<p>350728 TAŞIYICI ÖN FİTİL 3mm / MULLION FRONT GASKET 3mm BİRİM AĞIRLIK / UNIT WEIGHT: 47 g/m KOLİ MİKTARI / PACKAGE QUANTITY: 316 m</p>		
<p>350729 TAŞIYICI ÖN FİTİL 4mm / MULLION FRONT GASKET 4mm BİRİM AĞIRLIK / UNIT WEIGHT: 56 g/m KOLİ MİKTARI / PACKAGE QUANTITY: 266 m</p>		
<p>350746 TAŞIYICI ÖN FİTİL 5mm / MULLION FRONT GASKET 5mm BİRİM AĞIRLIK / UNIT WEIGHT: 58 g/m KOLİ MİKTARI / PACKAGE QUANTITY: 260 m</p>		
<p>350747 TAŞIYICI ÖN FİTİL 7mm / MULLION FRONT GASKET 7mm BİRİM AĞIRLIK / UNIT WEIGHT: 71 g/m KOLİ MİKTARI / PACKAGE QUANTITY: 212 m</p>		

AKSESUAR KODU VE ÜRÜN BİLGİLERİ / ACCESSORY CODE AND PRODUCT DESCRIPTION	ÇİZİM / DRAWING	TAKILMA BÖLGESİ / APPLICATION AREA
<p>350748 KANAT ÇARŞAF FİTİLİ / SHEET GASKET FOR VENT BİRİM AĞIRLIK / UNIT WEIGHT: 125 g/m KOLİ MİKTARI / PACKAGE QUANTITY: 120 m</p>		
<p>350749 KANAT ÇARŞAF FİTİLİ / SHEET GASKET FOR VENT BİRİM AĞIRLIK / UNIT WEIGHT: 153 g/m KOLİ MİKTARI / PACKAGE QUANTITY: 98 m</p>		
<p>350750 KANAT ÇARŞAF FİTİLİ / SHEET GASKET FOR VENT BİRİM AĞIRLIK / UNIT WEIGHT: 185 g/m KOLİ MİKTARI / PACKAGE QUANTITY: 81 m</p>		
<p>350751 KANAT ÇARŞAF FİTİLİ / SHEET GASKET FOR VENT BİRİM AĞIRLIK / UNIT WEIGHT: 229 g/m KOLİ MİKTARI / PACKAGE QUANTITY: 66 m</p>		
<p>350752 POLİETİLEN DERZ FİTİL / POLYETHYLENE SEAM GASKET BİRİM AĞIRLIK / UNIT WEIGHT: 30 g/m KOLİ MİKTARI / PACKAGE QUANTITY: 500 m</p>		
<p>350753 İÇ MEKAN DERZ KAPATMA FİTİLİ / INSIDE SEAM GASKET BİRİM AĞIRLIK / UNIT WEIGHT: 204 g/m KOLİ MİKTARI / PACKAGE QUANTITY: 73 m</p>		
<p>350754 SİLİKON DERZ KAPATMA FİTİLİ / SILICONE SEAM GASKET BİRİM AĞIRLIK / UNIT WEIGHT: 194 g/m KOLİ MİKTARI / PACKAGE QUANTITY: 77 m</p>		
<p>350755 VULKANİZE KÖŞE PARÇASI / VULCANISED CORNER PIECE İLİŞKİLİ FİTİLLER / RELATED GASKETS: 350700 & 350706</p>		
<p>350756 VULKANİZE KÖŞE PARÇASI / VULCANISED CORNER PIECE İLİŞKİLİ FİTİL / RELATED GASKET: 350726</p>		

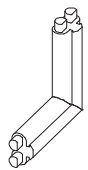
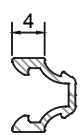
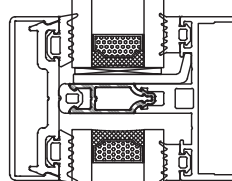
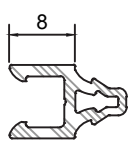
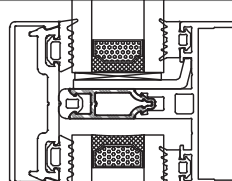
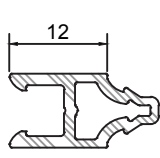
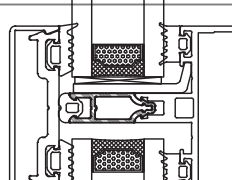
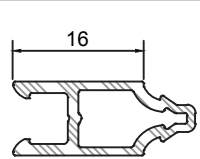
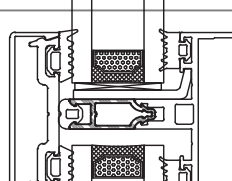
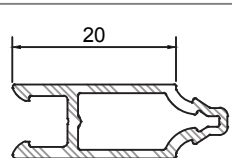
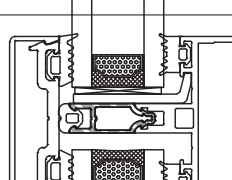
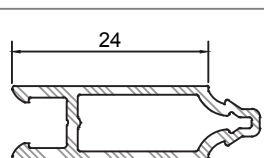
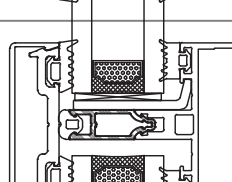
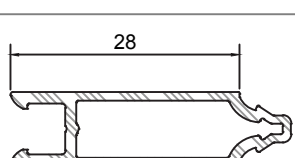
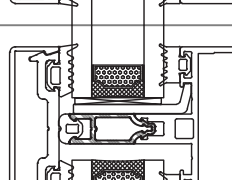
AKSESUAR KODU VE ÜRÜN BİLGİLERİ / ACCESSORY CODE AND PRODUCT DESCRIPTION	ÇİZİM / DRAWING	TAKILMA BÖLGESİ / APPLICATION AREA
<p>350757 VULKANİZE KÖŞE PARÇASI / VULCANISED CORNER PIECE İLİŞKİLİ FİTİL / RELATED GASKET: 350727</p>		
<p>350769 TAŞIYICI ÖN İZOLASYON (PVC) 4 MM MULLION OR TRANSOM FRONT ISOLATOR (PVC) MİKTAR / QUANTITY: BOY 6 m /Adet</p>		
<p>350770 TAŞIYICI ÖN İZOLASYON (PVC) 8 MM MULLION OR TRANSOM FRONT ISOLATOR (PVC) MİKTAR / QUANTITY: BOY 6 m /Adet</p>		
<p>350771 TAŞIYICI ÖN İZOLASYON (PVC) 12 MM MULLION OR TRANSOM FRONT ISOLATOR (PVC) MİKTAR / QUANTITY: BOY 6 m /Adet</p>		
<p>350772 TAŞIYICI ÖN İZOLASYON (PVC) 16 MM MULLION OR TRANSOM FRONT ISOLATOR (PVC) MİKTAR / QUANTITY: BOY 6 m /Adet</p>		
<p>350773 TAŞIYICI ÖN İZOLASYON (PVC) 20 MM MULLION OR TRANSOM FRONT ISOLATOR (PVC) MİKTAR / QUANTITY: BOY 6 m /Adet</p>		
<p>350774 TAŞIYICI ÖN İZOLASYON (PVC) 24 MM MULLION OR TRANSOM FRONT ISOLATOR (PVC) MİKTAR / QUANTITY: BOY 6 m /Adet</p>		
<p>350775 TAŞIYICI ÖN İZOLASYON (PVC) 28 MM MULLION OR TRANSOM FRONT ISOLATOR (PVC) MİKTAR / QUANTITY: BOY 6 m /Adet</p>		

AKSESUAR KODU VE ÜRÜN BİLGİLERİ / ACCESSORY CODE AND PRODUCT DESCRIPTION	ÇİZİM / DRAWING	KESİM ÖLÇÜSÜ / CUTTING DIMENSION
<p>350621 KÖŞE TAKOZU / CORNER CLEAT PROFİL NUMARASI / PROFILE NUMBER: 354988 PROFİL AĞIRLIĞI / PROFILE WEIGHT: 1,974 kg/m.</p>		<p>29,4 mm</p>
<p>350622 KÖŞE TAKOZU / CORNER CLEAT PROFİL NUMARASI / PROFILE NUMBER: 354988 PROFİL AĞIRLIĞI / PROFILE WEIGHT: 1,974 kg/m.</p>		<p>11 mm</p>
<p>350623 KÖŞE TAKOZU / CORNER CLEAT PROFİL NUMARASI / PROFILE NUMBER: 354988 PROFİL AĞIRLIĞI / PROFILE WEIGHT: 1,974 kg/m.</p>		<p>13 mm</p>
<p>350624 KÖŞE TAKOZU / CORNER CLEAT PROFİL NUMARASI / PROFILE NUMBER: 354988 PROFİL AĞIRLIĞI / PROFILE WEIGHT: 1,974 kg/m.</p>		<p>44,9 mm</p>
<p>350625 KÖŞE TAKOZU / CORNER CLEAT PROFİL NUMARASI / PROFILE NUMBER: 354988 PROFİL AĞIRLIĞI / PROFILE WEIGHT: 1,974 kg/m.</p>		<p>21 mm</p>
<p>350626 KÖŞE TAKOZU / CORNER CLEAT PROFİL NUMARASI / PROFILE NUMBER: 354988 PROFİL AĞIRLIĞI / PROFILE WEIGHT: 1,974 kg/m.</p>		<p>17 mm</p>
<p>350627 KÖŞE TAKOZU / CORNER CLEAT PROFİL NUMARASI / PROFILE NUMBER: 354988 PROFİL AĞIRLIĞI / PROFILE WEIGHT: 1,974 kg/m.</p>		<p>23 mm</p>
<p>350628 KÖŞE TAKOZU / CORNER CLEAT PROFİL NUMARASI / PROFILE NUMBER: 354988 PROFİL AĞIRLIĞI / PROFILE WEIGHT: 1,974 kg/m.</p>		<p>19 mm</p>

AKSESUAR KODU VE ÜRÜN BİLGİLERİ / ACCESSORY CODE AND PRODUCT DESCRIPTION	ÇİZİM / DRAWING	KESİM ÖLÇÜSÜ / CUTTING DIMENSION
<p>350629 KÖŞE TAKOZU / CORNER CLEAT PROFİL NUMARASI / PROFILE NUMBER: 354989 PROFİL AĞIRLIĞI / PROFILE WEIGHT: 2,367 kg/m.</p>		<p>24,7 mm</p>
<p>350630 KÖŞE TAKOZU / CORNER CLEAT PROFİL NUMARASI / PROFILE NUMBER: 354989 PROFİL AĞIRLIĞI / PROFILE WEIGHT: 2,367 kg/m.</p>		<p>7 mm</p>
<p>350631 KÖŞE TAKOZU / CORNER CLEAT PROFİL NUMARASI / PROFILE NUMBER: 354989 PROFİL AĞIRLIĞI / PROFILE WEIGHT: 2,367 kg/m.</p>		<p>26,9 mm</p>
<p>350632 KÖŞE TAKOZU / CORNER CLEAT PROFİL NUMARASI / PROFILE NUMBER: 354989 PROFİL AĞIRLIĞI / PROFILE WEIGHT: 2,367 kg/m.</p>		<p>17,5 mm</p>
<p>350635 KÖŞE TAKOZU / CORNER CLEAT PROFİL NUMARASI / PROFILE NUMBER: 354989 PROFİL AĞIRLIĞI / PROFILE WEIGHT: 2,367 kg/m.</p>		<p>26 mm</p>
<p>350636 KÖŞE TAKOZU / CORNER CLEAT PROFİL NUMARASI / PROFILE NUMBER: 354989 PROFİL AĞIRLIĞI / PROFILE WEIGHT: 2,367 kg/m.</p>		<p>9 mm</p>
<p>350637 KÖŞE TAKOZU / CORNER CLEAT PROFİL NUMARASI / PROFILE NUMBER: 354989 PROFİL AĞIRLIĞI / PROFILE WEIGHT: 2,367 kg/m.</p>		<p>24,4 mm</p>
<p>350638 KÖŞE TAKOZU / CORNER CLEAT PROFİL NUMARASI / PROFILE NUMBER: 354989 PROFİL AĞIRLIĞI / PROFILE WEIGHT: 2,367 kg/m.</p>		<p>39,6 mm</p>
<p>350776 KÖŞE ÇAVUŞU / CORNET ALIGNMENT MALZEME / MATERIAL: POLYAMID</p>		<p>16 x 1,5</p>



ÜRÜN KODU PRODUCT CODE	MAKAS BOYU FRICTION STAY LENGTH (inch)	MAKAS BOYU FRICTION STAY LENGTH (mm)	KANAT AÇMA DERECESİ OPENING ANGLE	MAKS. KANAT YÜKSEKLİĞİ MAX. VENT HEIGHT (mm)	MAKS. KANAT AĞIRLIĞI MAX. VENT WEIGHT (kg)
350795	10"	255	35°	700	50
350796	12"	305	30°/35°	800	60
350797	14"	355	30°/35°	1000	70
350798	16"	405	25°/30°	1200	90
350799	18"	460	25°/30°	1400	100
350800	20"	505	20°/25°	1600	135
350801	22"	560	20°/25°	1700	140
350802	24"	610	20°/25°	1800	145
350803	26"	660	10°/15°/20°	2000	155
350804	28"	710	10°/15°/20°	2500	180

! TABLODA BELİRTİLEN TEKNİK DEĞERLER, İTHAL ÜRÜNLERE AİTTİR. YERLİ ALTERNATİFLERİ İÇİN DEĞERLER FARKLI OLABİLİR.
TECHNICAL VALUES ARE BELONG TO IMPORTED PRODUCTS AS SHOWN AT THE TABLE. VALUES CAN BE DIFFERENT AT THE NATIVE ALTERNATIVES.

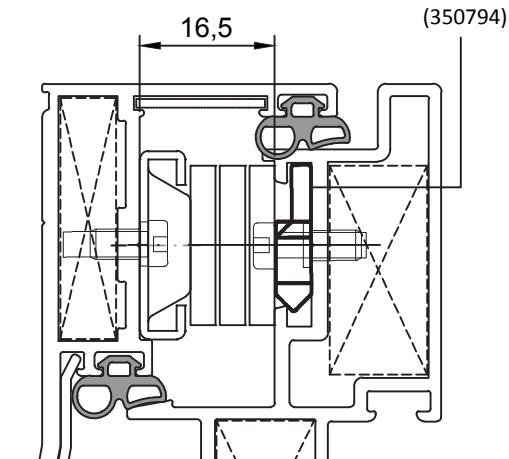

*** STANDART AKSESUAR SETİNDE YER ALMAYAN 46012 KODLU METRİK PERÇİN VE VİDALARIN KULLANILMASI DURUMUNDA TÜM MAKAS TİPLERİ İÇİN MAKSİMUM KANAT AĞIRLIĞI 180 KG OLUP ÜRETİCİ FİRMA GARANTİSİ ALTINDADIR.**
IF USING THE METRIC PIN & SCREWS WITH THE CODE OF 46012 WHICH DOESN'T INCLUDE AT STANDARD ACCESSORY KIT, MAXIMUM CARRIAGE CAPACITY FIXED TO 180 KG FOR ALL FRICTION STAY TYPES.

350794
METRİK PERÇİN VE VİDA SETİ
METRIC PIN AND SCREW KIT

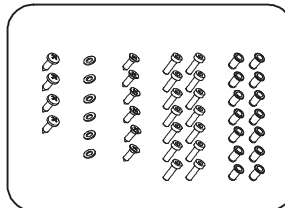

350782
MAKAS ALTI BESLEME TAKOZU (PVC)
FRICTION STAY REINFORCEMENT PLUG (PVC)

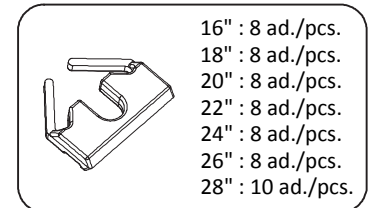

! BU SAYFADA BELİRTİLEN AKSESUAR GÖRSELLERİ TEMSİLİDİR.
ACCESSORY IMAGES ARE REPRESENTATIVE AT THIS PAGE.

MAKAS SEÇİM DİYAGRAMI / FRICTION STAY SELECTION DIAGRAM

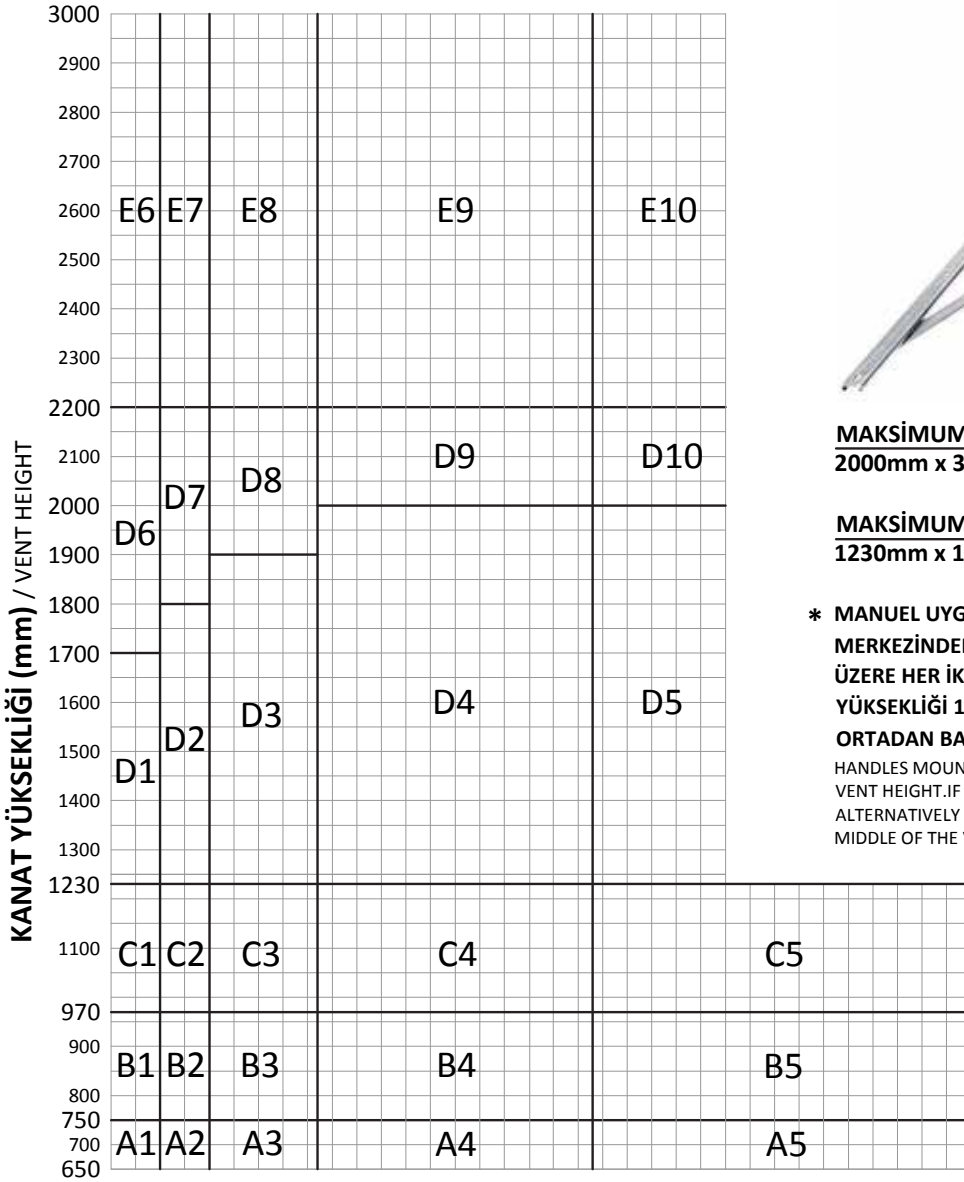

MAKSİMUM MOTORLU UYGULAMA ÖLÇÜSÜ:
2000mm x 3000mm

MAKSİMUM MANUEL UYGULAMA ÖLÇÜSÜ:
1230mm x 1500mm

* MANUEL UYGULAMADA KOLLAR KANAT YÜKSEKLİĞİNİN MERKEZİNDEN +/- 15% MESAFESİNE SAĞ VE SOL OLMAK ÜZERE HER İKİ TARAFA MONTAJLANMALIDIR. KANAT YÜKSEKLİĞİ 1230 mm'NİN ALTINDA İSE KANATLAR ALT ORTADAN BAĞLANAN TEK KOL İLE AÇILABİLİR.

HANDLES MOUNTED CENTRALLY ON THE VERTICAL SIDES +/- 15% OF THE VENT HEIGHT. IF THE VENTS HEIGHT BELOW 1230 mm HIGH, IT CAN ALTERNATIVELY BE OPERATED FROM A SINGLE HANDLE AT THE BOTTOM MIDDLE OF THE VENT.

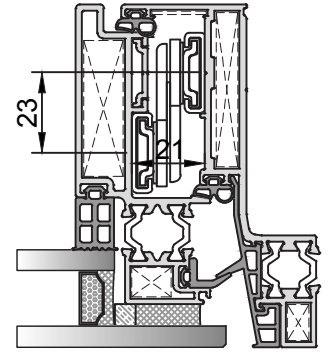

KANAT GENİŞLİĞİ (mm) / VENT WIDTH

YAN MAKASLAR SIDE MOUNTED FRICTION STAYS					ALT&ÜST KONTROL MAKASLARI TOP&BOTTOM CONTROL FRICTION STAYS		
	SOL TARAF LEFT SIDE	SAĞ TARAF RIGHT SIDE	STOPLAMALAR STOPPERS	MAKS. AĞIRLIK MAX. WEIGHT (mm)		ÜST TOP	ALT BOTTOM
A	1 x 350826	1 x 350830	2 x 350834	100	1	350838	-
B	1 x 350827	1 x 350831	2 x 350835	100	2	350830	-
C	1 x 350828	1 x 350832	2 x 350836	200	3	350831	-
D	1 x 350829	1 x 350833	2 x 350837	200	4	350832	-
E	2 x 350829	2 x 350833	4 x 350837	200	5	350833	-
* 350838 KONTROL MAKASLARI KULLANILIRKEN 350835 STOPLAMA YERİNE 350834 KULLANILIR. / WHEN USING 350838 KONTROL FRICTION STAYS, REPLACE 350835 STOPPERS WITH 350834 STOPPERS. * MANUEL UYGULAMALAR İÇİN KANATLARIN MAKSİMUM AÇILMA MESAFESİ 150 mm 'DİR. / MAXIMUM OPENING DISTANCE FOR VENTS ARE 150 mm FOR MANUAL APPLICATIONS. * PARALEL MAKAS FİYATLANDIRMASI İÇİN LÜTFEN SİSTEM ALÜMİNYUM'A BAŞVURUNUZ. / FOR PARALEL FRICTION STAY PRICING DETAILS PLEASE CONTACT WITH SİSTEM ALUMINIUM.					6	350838	350838
					7	350830	350830
					8	350831	350831
					9	350832	350832
					10	350833	350833

! BU SAYFADA BELİRTİLEN AKSESUAR GÖRSELLERİ TEMSİLDİR.
ACCESSORY IMAGES ARE REPRESENTATIVE AT THIS PAGE.

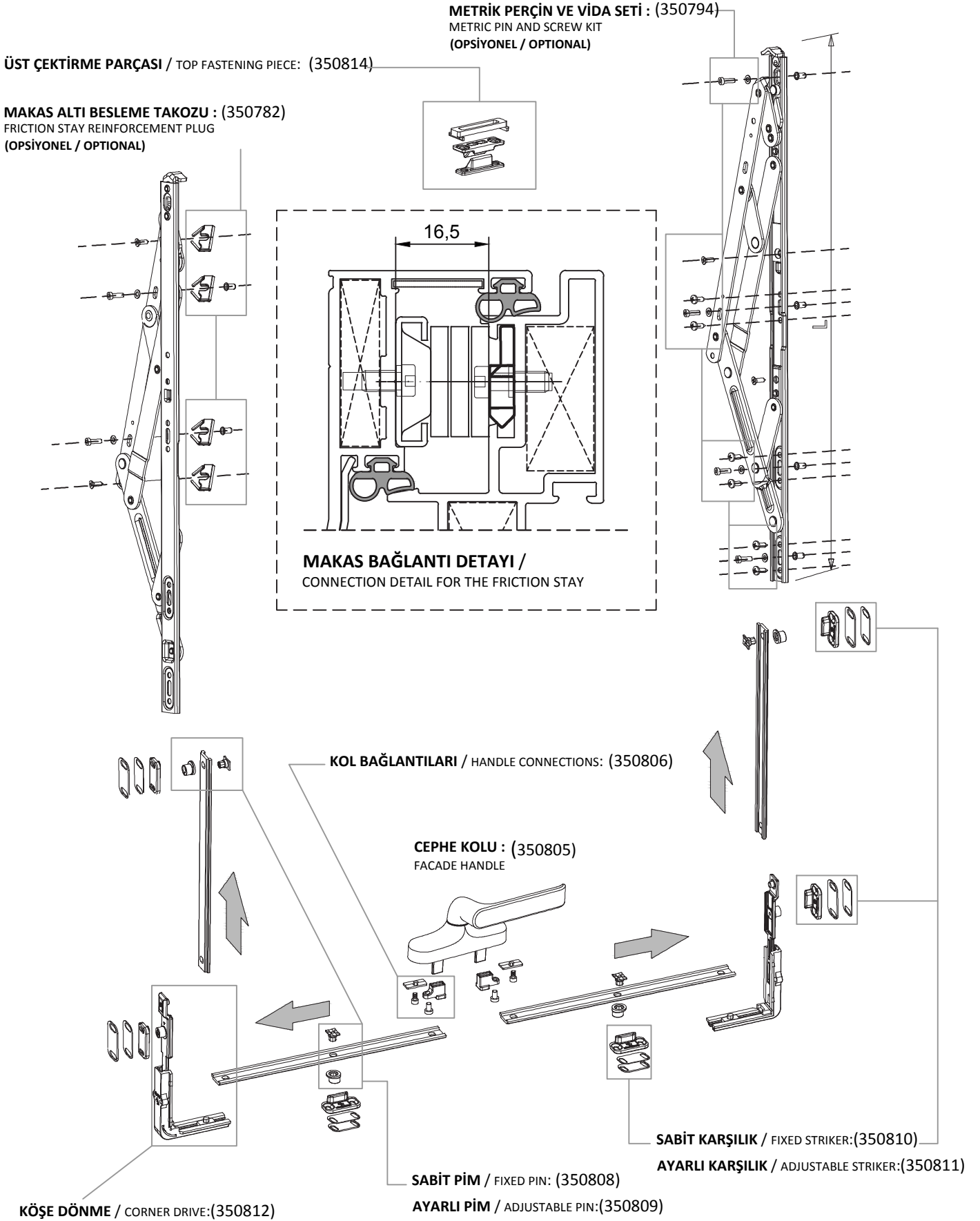

350822

KANAT YÜKSEKLİĞİ
VENT HEIGHT
600 - 1200 mm

KANAT GENİŞLİĞİ
VENT WIDTH
600 - 1000 mm

350823

KANAT YÜKSEKLİĞİ
VENT HEIGHT
1200 - 1600 mm

KANAT GENİŞLİĞİ
VENT WIDTH
1000 - 1200 mm

350824

KANAT YÜKSEKLİĞİ
VENT HEIGHT
1600 - 1800 mm

KANAT GENİŞLİĞİ
VENT WIDTH
1200 - 1600 mm







350825

KANAT YÜKSEKLİĞİ
VENT HEIGHT
1800 - 2500 mm

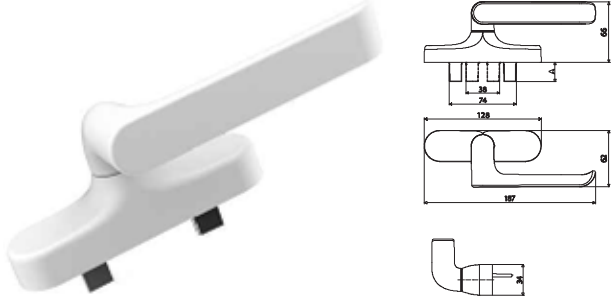
KANAT GENİŞLİĞİ
VENT WIDTH
1600 - 2000 mm

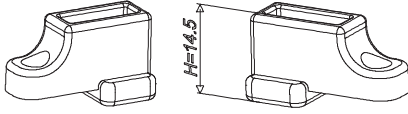
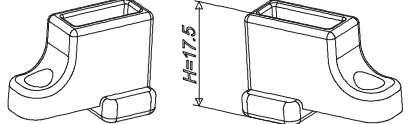

SET KODU / KIT CODE :		350822	350823	350824	350825
ÜRÜN KODU PRODUCT CODE	ÜRÜN ADI PRODUCT NAME	2 NOKTADAN KİTLEME 2 POINTS LOCKING	7 NOKTADAN KİTLEME 7 POINTS LOCKING	10 NOKTADAN KİTLEME 10 POINTS LOCKING	15 NOKTADAN KİTLEME 15 POINTS LOCKING
350805	CEPHE KOLU CURTAIN WALL HANDLE	1 ADET / PCS.	1 ADET / PCS.	1 ADET / PCS.	1 ADET / PCS.
350806	KOL BAĞLANTILARI HANDLE CONNECTIONS	2 ADET / PCS.	2 ADET / PCS.	2 ADET / PCS.	2 ADET / PCS.
350809	AYARLI PİM ADJUSTABLE PIN	2 ADET / PCS.	4 ADET / PCS.	6 ADET / PCS.	10 ADET / PCS.
350811	AYARLI KARŞILIK ADJUSTABLE STRIKER	2 ADET / PCS.	6 ADET / PCS.	8 ADET / PCS.	12 ADET / PCS.
350812	KÖŞE DÖNME CORNER DRIVE	-	2 ADET / PCS.	2 ADET / PCS.	2 ADET / PCS.
350814	ÜST ÇEKTİRME PARÇASI TOP FASTENING PIECE	-	1 ADET / PCS.	2 ADET / PCS.	3 ADET / PCS.

! BU SAYFADA BELİRTİLEN AKSESUAR GÖRSELLERİ TEMSİLİDİR.
ACCESSORY IMAGES ARE REPRESENTATIVE AT THIS PAGE.

<p>AKSESUAR KODU VE ÜRÜN BİLGİLERİ / ACCESSORY CODE AND PRODUCT DESCRIPTION</p>	<p>GÖRSELLER / IMAGES</p>
<p>350805 <i>CEPHE KOLU / FACADE HANDLE</i></p>	
<p>350819 <i>ANAHTARLI CEPHE KOLU / FACADE HANDLE WITH KEY</i></p>	
<p>350820 <i>SÖKÜLEBİLİR CEPHE KOLU MEKANİZMASI /</i> <i>DETACHABLE FACADE CREMONE MECANISM</i></p>	
<p>350821 <i>SÖKÜLEBİLİR CEPHE KOLU SAPI /</i> <i>DETACHABLE FACADE HANDLE</i></p>	
<p>350806 <i>CEPHE KOLU BAĞLANTI ELEMANI /</i> <i>FACADE HANDLE FASTENING ELEMENT</i></p>	 <p>14,5mm</p>
<p>350807 <i>CEPHE KOLU BAĞLANTI ELEMANI /</i> <i>FACADE HANDLE FASTENING ELEMENT</i></p>	 <p>17,5mm</p>
<p>350808 <i>SABİT PİM / FIXED PIN</i></p>	

<p>AKSESUAR KODU VE ÜRÜN BİLGİLERİ / ACCESSORY CODE AND PRODUCT DESCRIPTION</p>	<p>GÖRSELLER / IMAGES</p>
<p>350809 <i>AYARLI PİM / ADJUSTABLE PIN</i></p>	
<p>350810 <i>SABİT KARŞILIK / FIXED STRIKER</i></p>	
<p>350811 <i>AYARLI KARŞILIK / ADJUSTABLE STRIKER</i></p>	
<p>350812 <i>KÖŞE DÖNÜŞ AKTARMA PARÇASI /</i> <i>CORNER TRANSFER DEVICE</i></p>	
<p>350813 <i>CEPHE MAKASLARI İÇİN YÜKSEKLİK AYAR PARÇASI /</i> <i>HEIGHT ADJUSTMENT PIECE FOR FRICTION STAYS</i></p>	

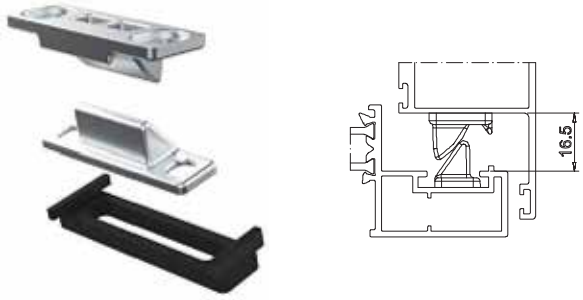
! BU SAYFADA BELİRTİLEN AKSESUAR GÖRSELLERİ TEMSİLDİR.
ACCESSORY IMAGES ARE REPRESENTATIVE AT THIS PAGE.

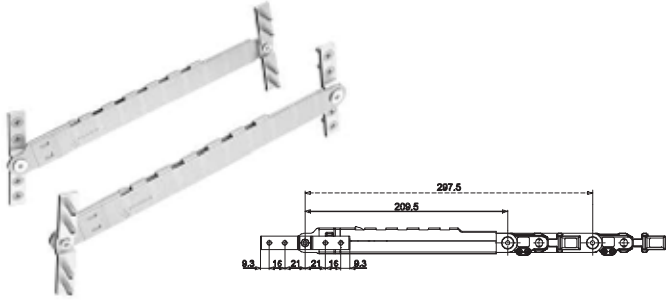
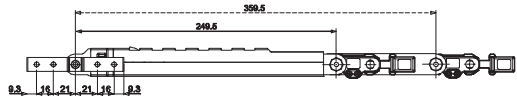
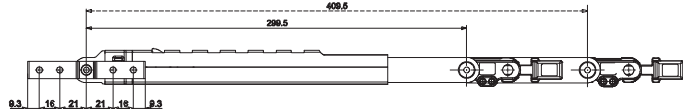
<p>AKSESUAR KODU VE ÜRÜN BİLGİLERİ / ACCESSORY CODE AND PRODUCT DESCRIPTION</p>	<p>GÖRSELLER / IMAGES</p>
<p>350814 ÜST ÇEKTİRME PARÇASI / TOP FASTENING PIECE</p>	
<p>350815 LİMİTLEME MAKASI / LIMITOR ARM</p>	
<p>350816 TELESKOPİK MAKAS (KÜÇÜK) / TELESCOPIC ARM (SMALL)</p>	
<p>350817 TELESKOPİK MAKAS (ORTA) / TELESCOPIC ARM (MEDIUM)</p>	
<p>350818 TELESKOPİK MAKAS (BÜYÜK) / TELESCOPIC ARM (LARGE)</p>	

CAM KALINLIKLARINA GÖRE ENTEGRE SİSTEM DETAYLARI
INTEGRATED CURTAIN WALL DETAILS ACCORDING TO THE GLASS THICKNESSES

32mm

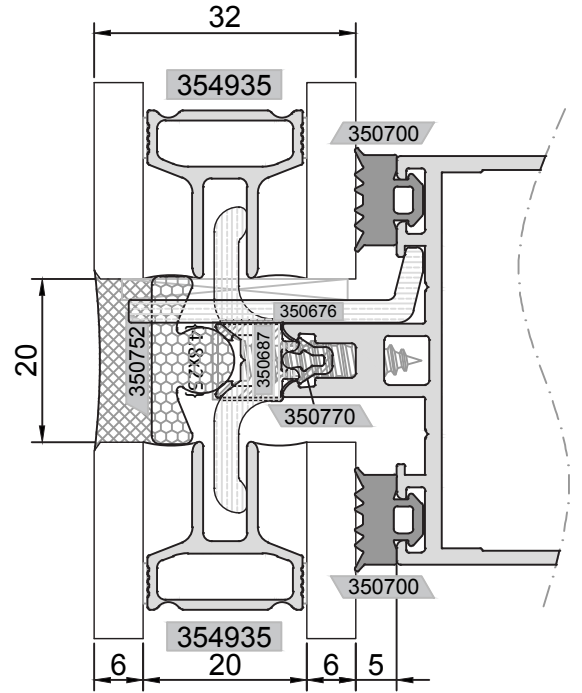
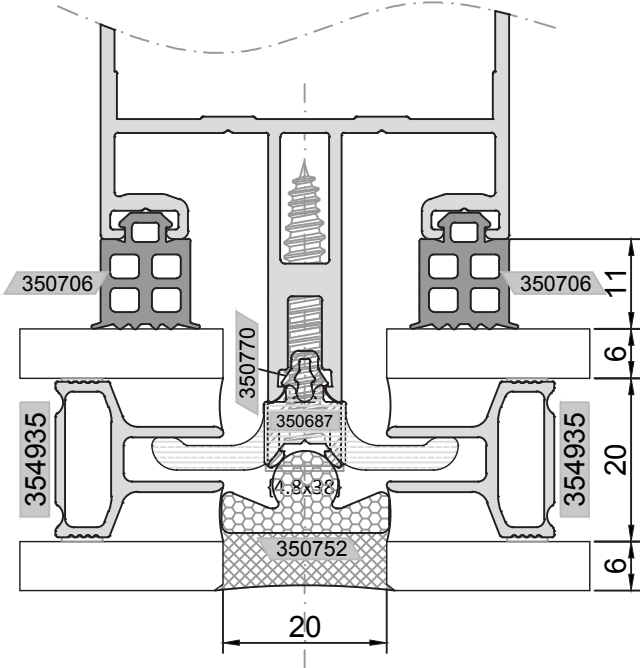

34mm

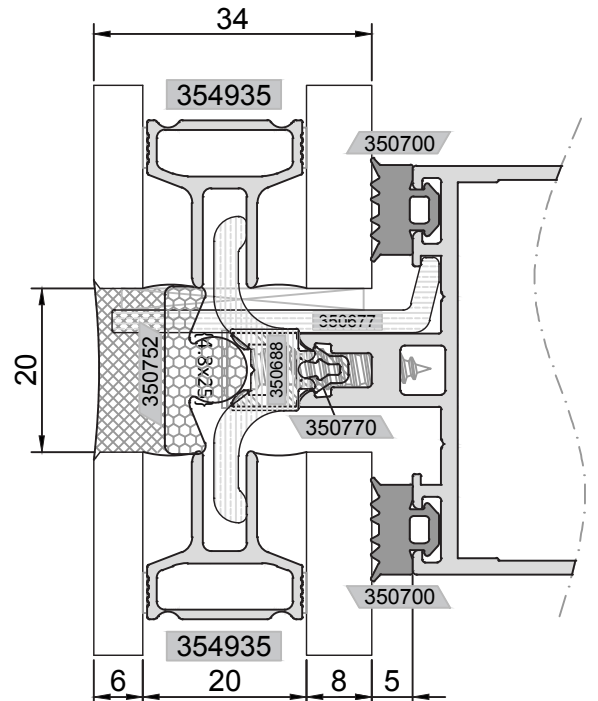
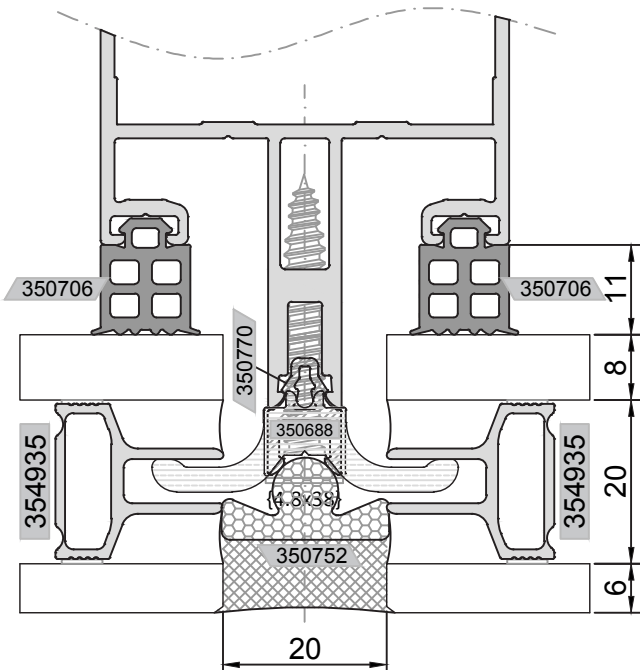

34,76mm

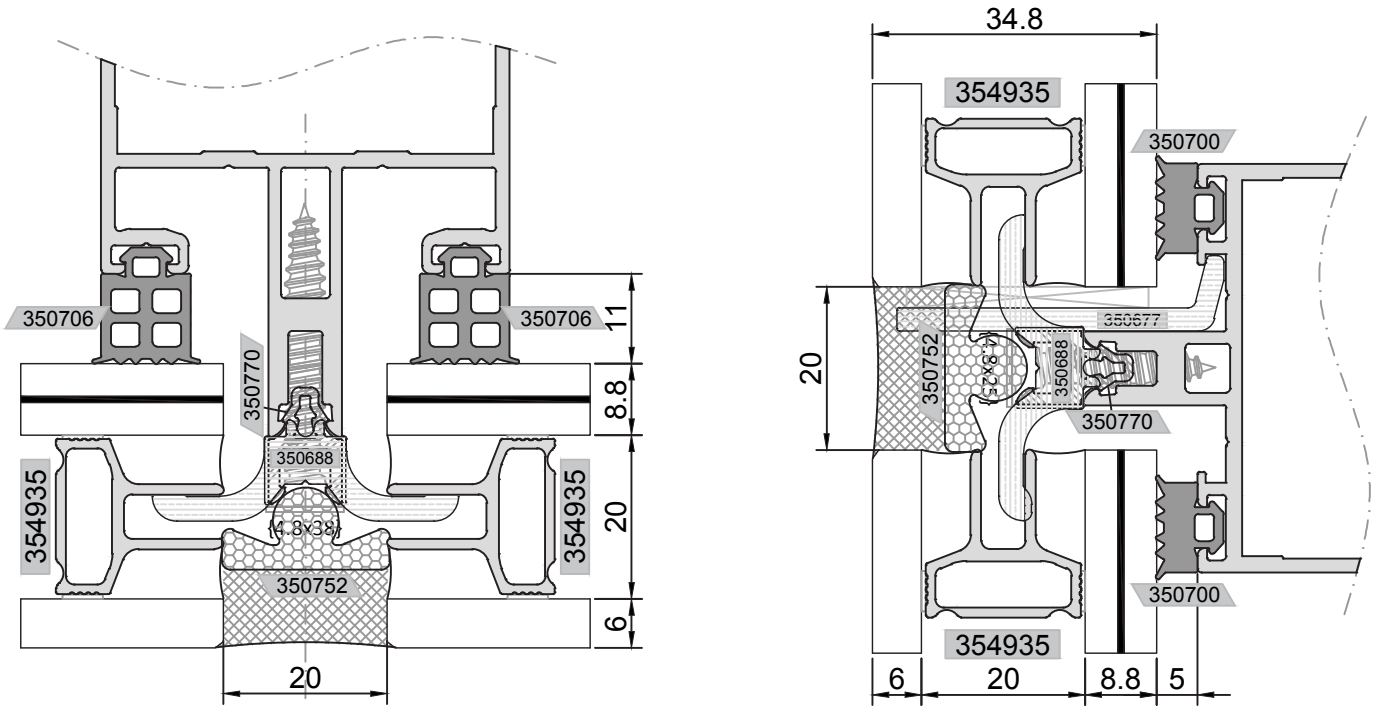

36mm

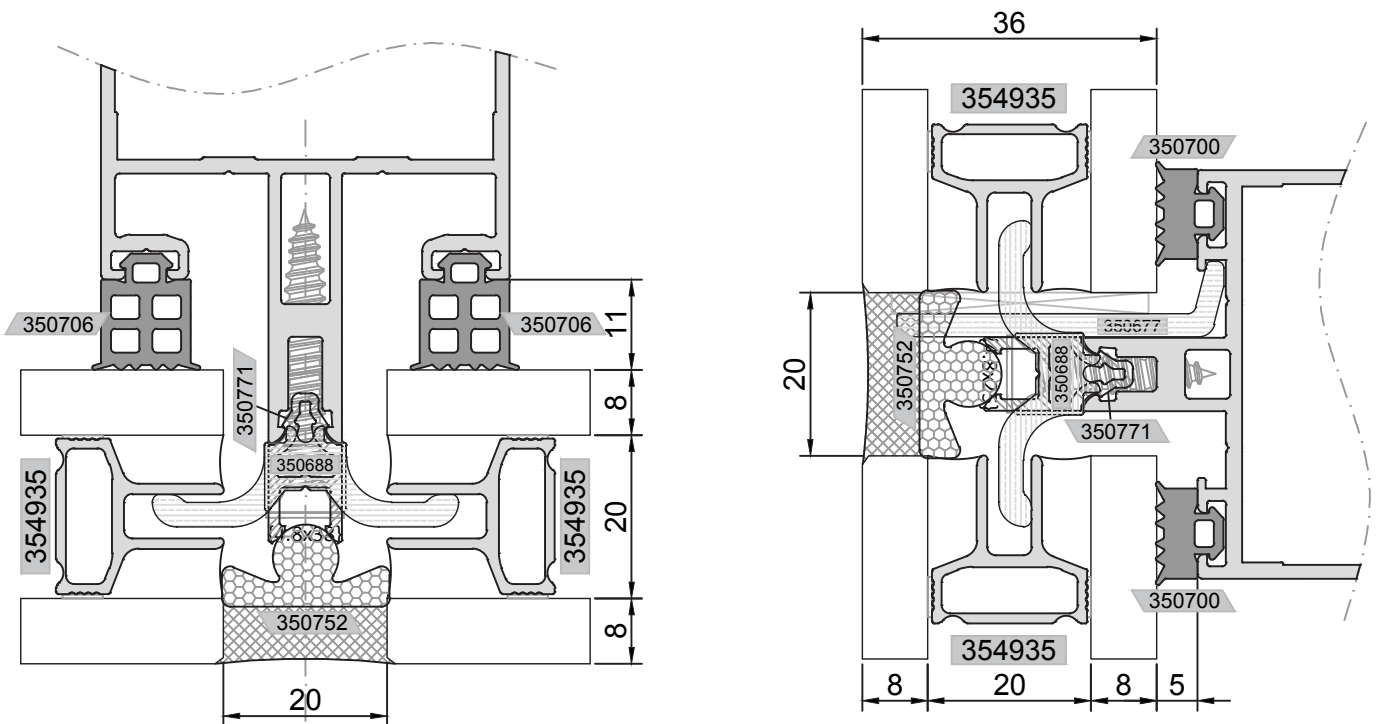

36,76mm

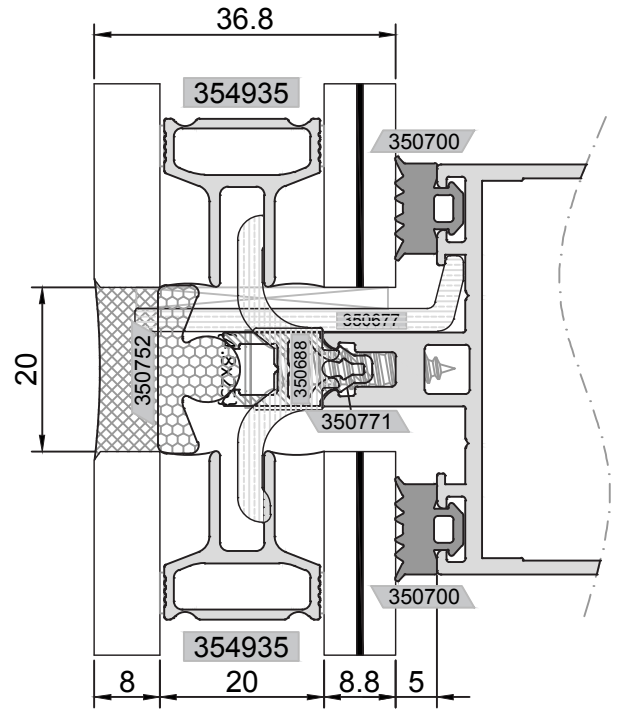
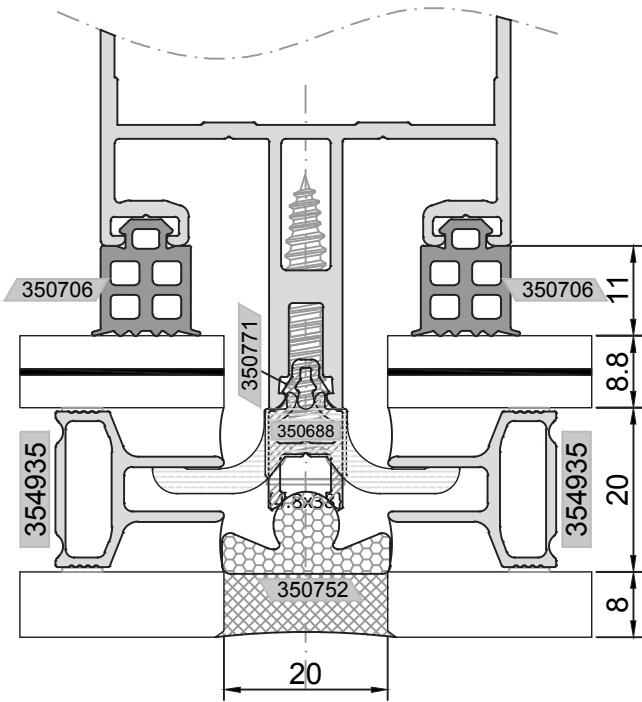

36,76mm

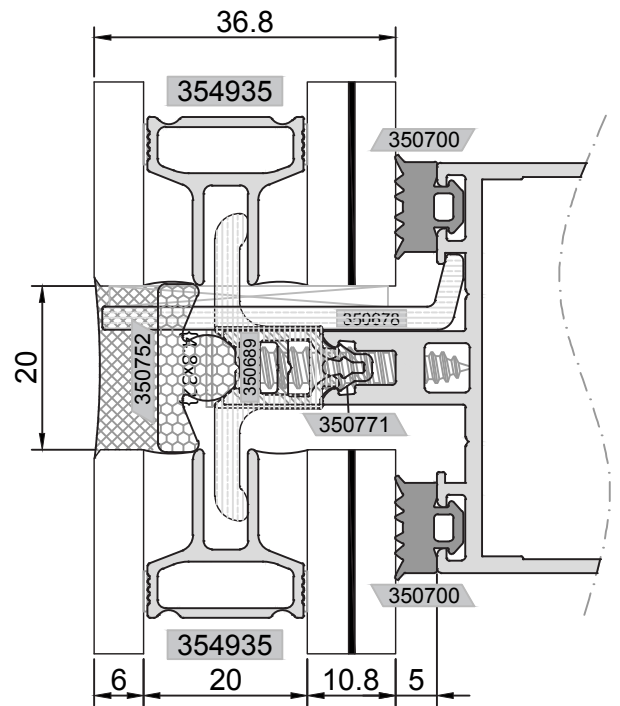
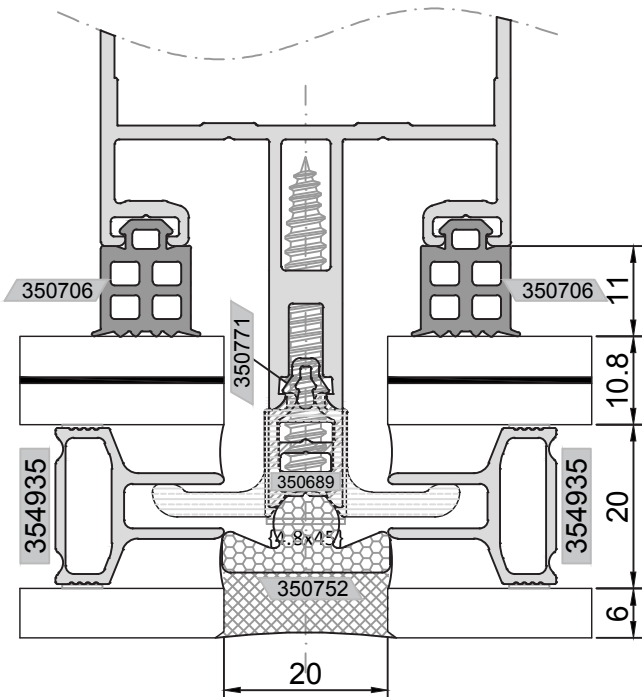

37,52mm

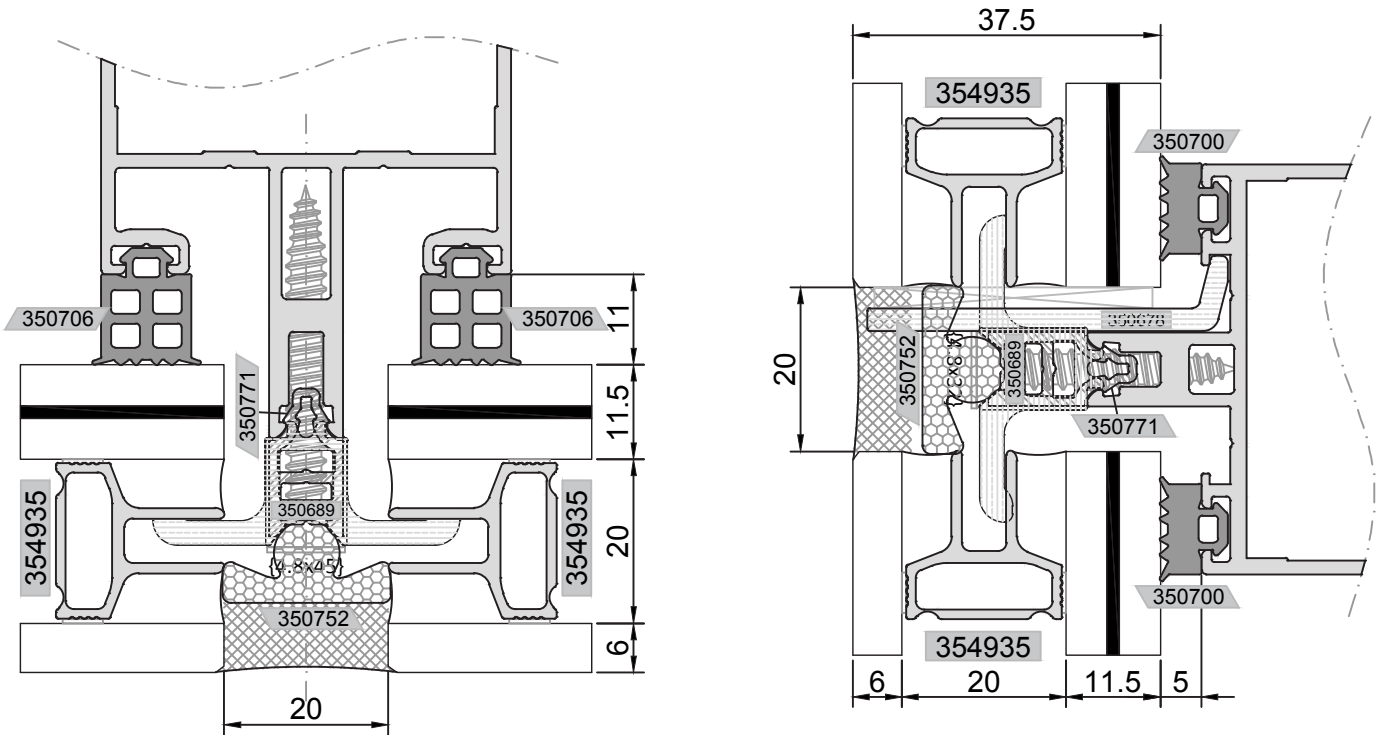

38,76mm

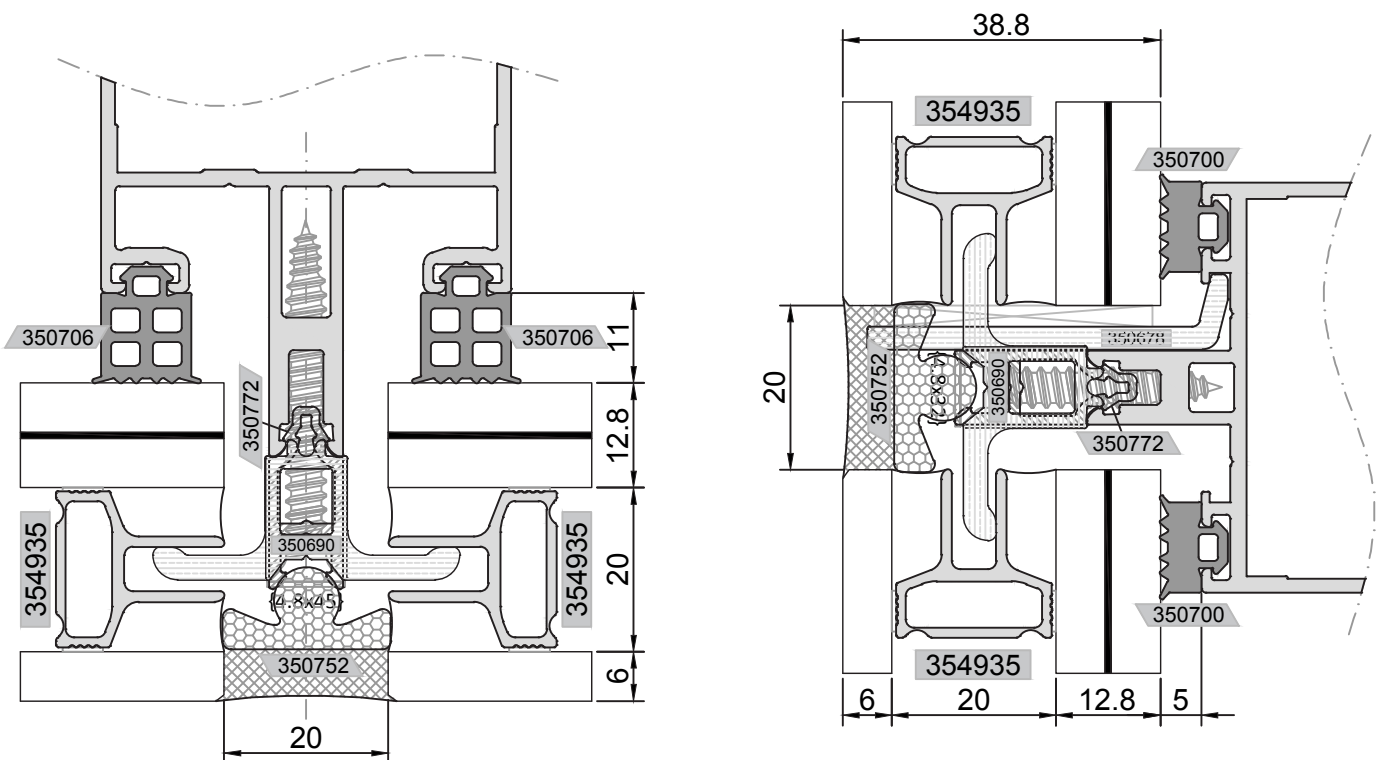

CAM KALINLIKLARINA GÖRE ENTEGRE SİSTEM DETAYLARI
 INTEGRATED CURTAIN WALL DETAILS ACCORDING TO THE GLASS THICKNESSES

39,52mm

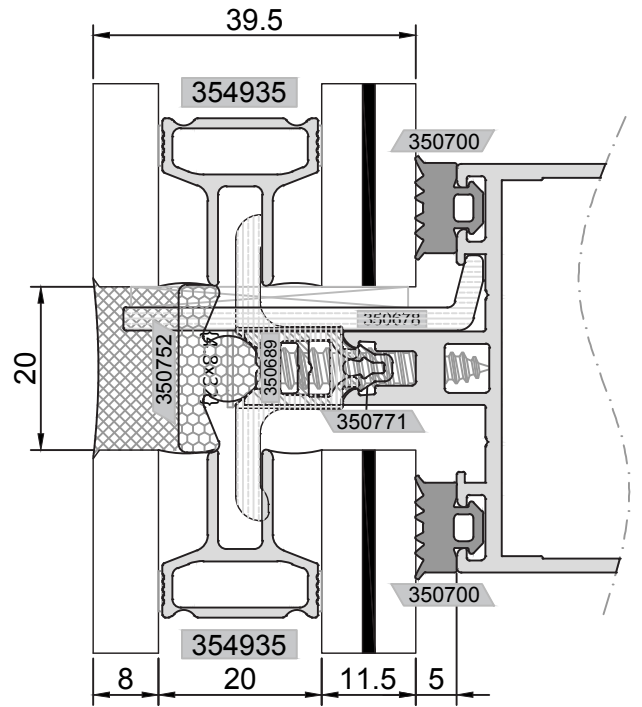
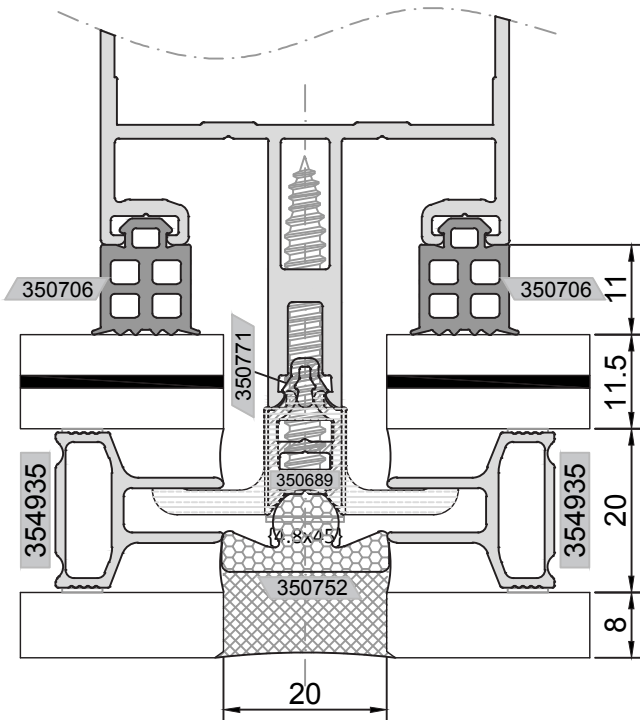

39,52mm

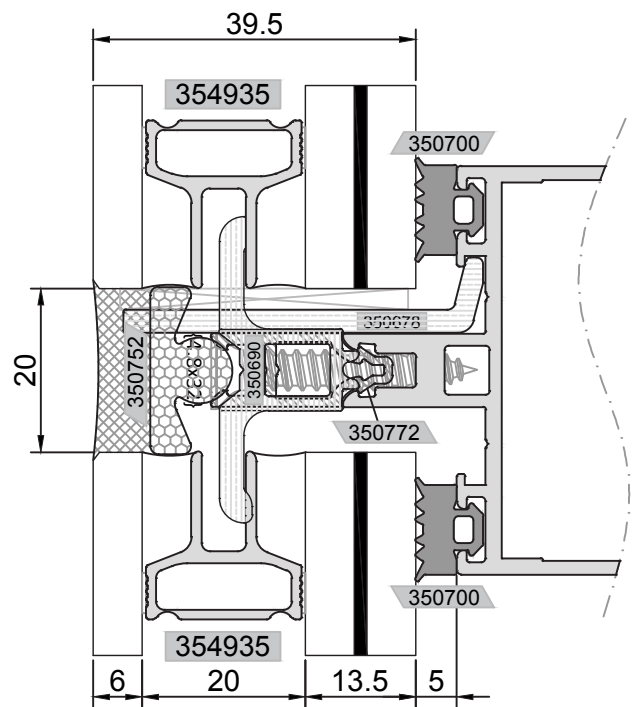
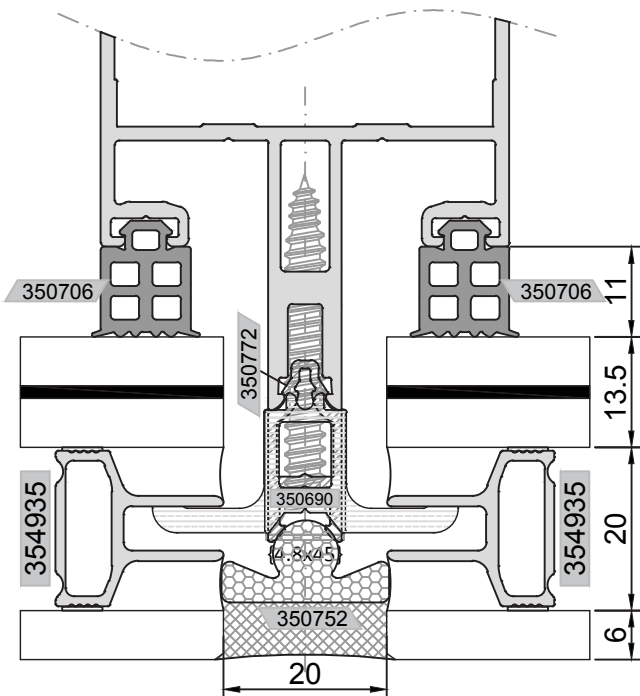

40,76mm

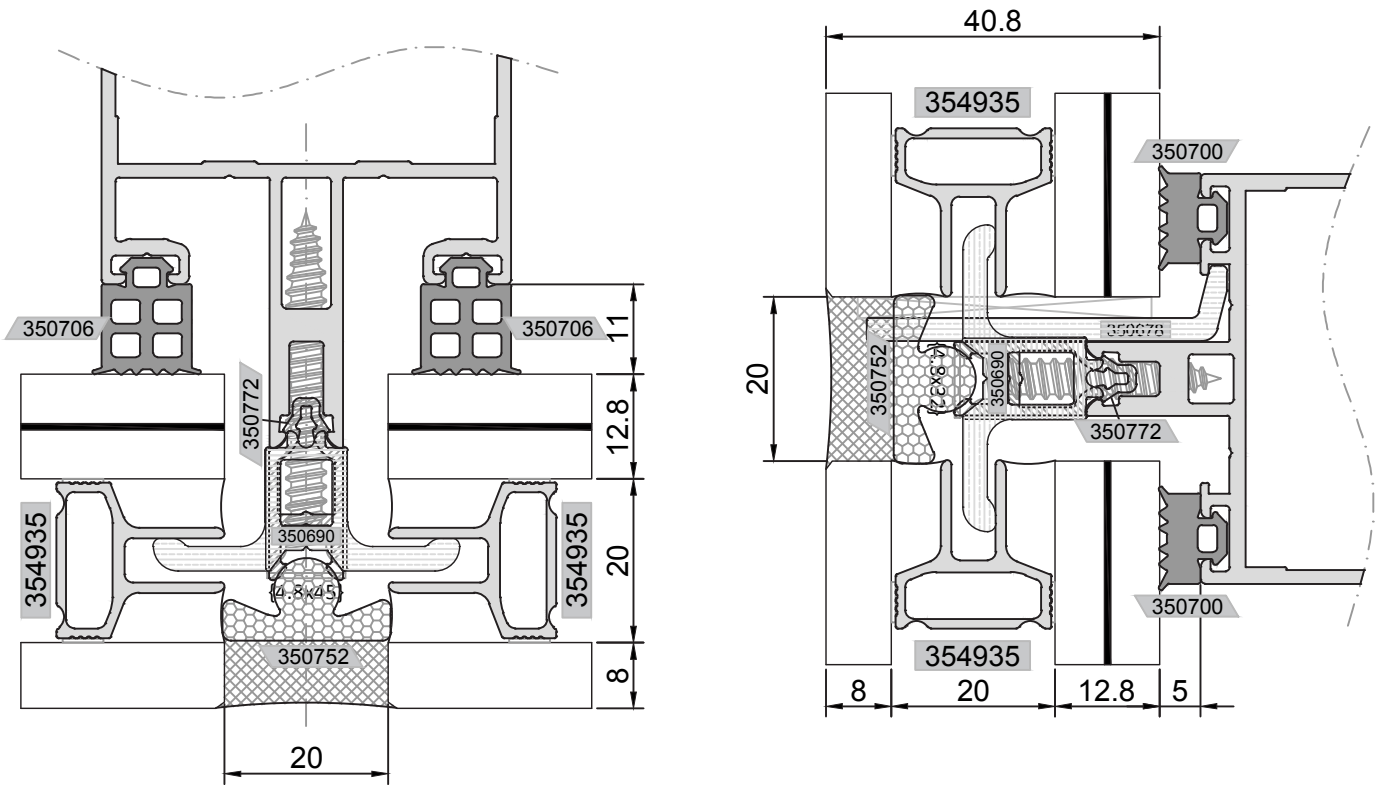

41,52mm

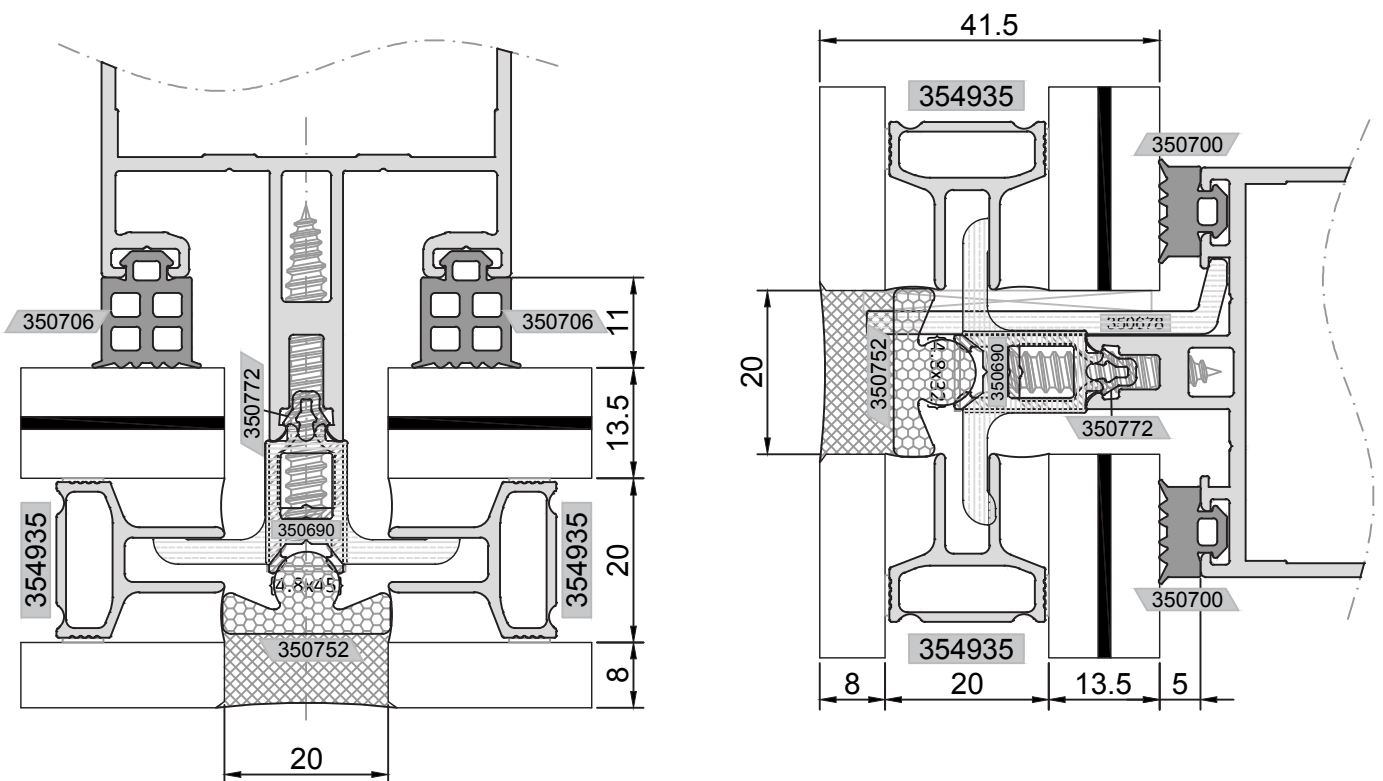

CAM KALINLIKLARINA GÖRE ENTEGRE SİSTEM DETAYLARI

INTEGRATED CURTAIN WALL DETAILS ACCORDING TO THE GLASS THICKNESSES

28mm

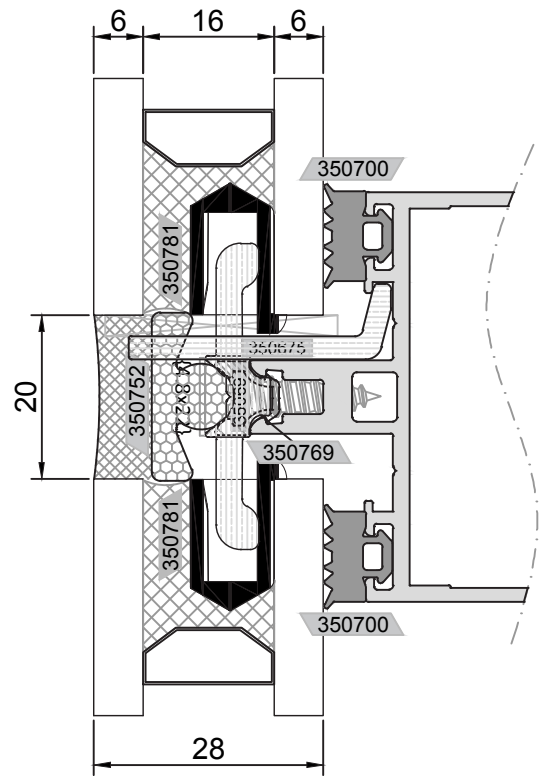
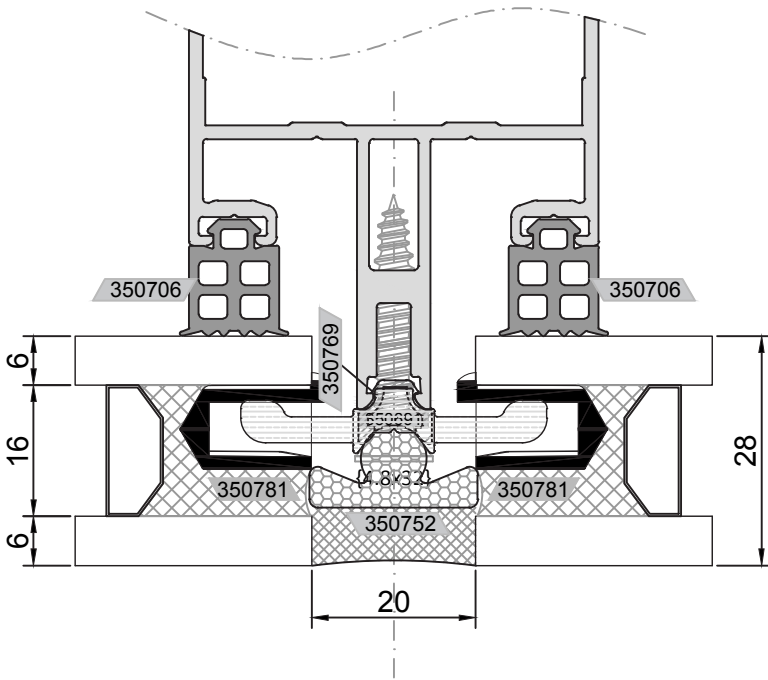

30mm

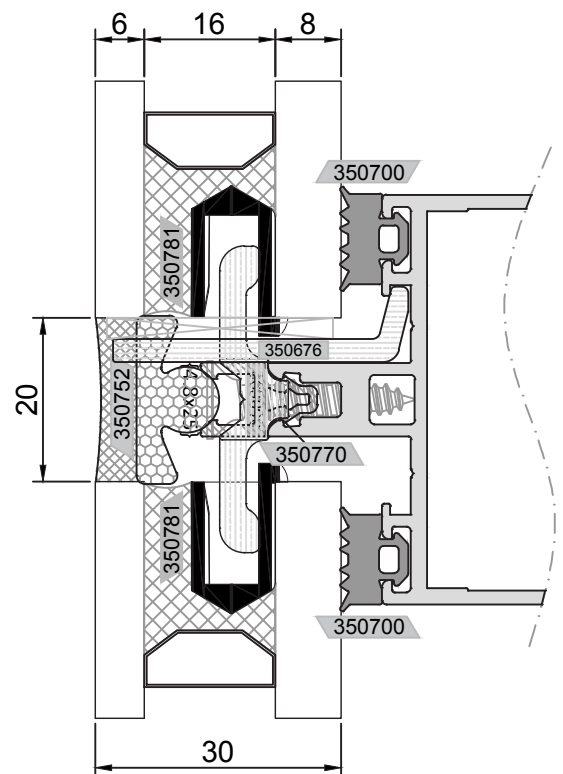
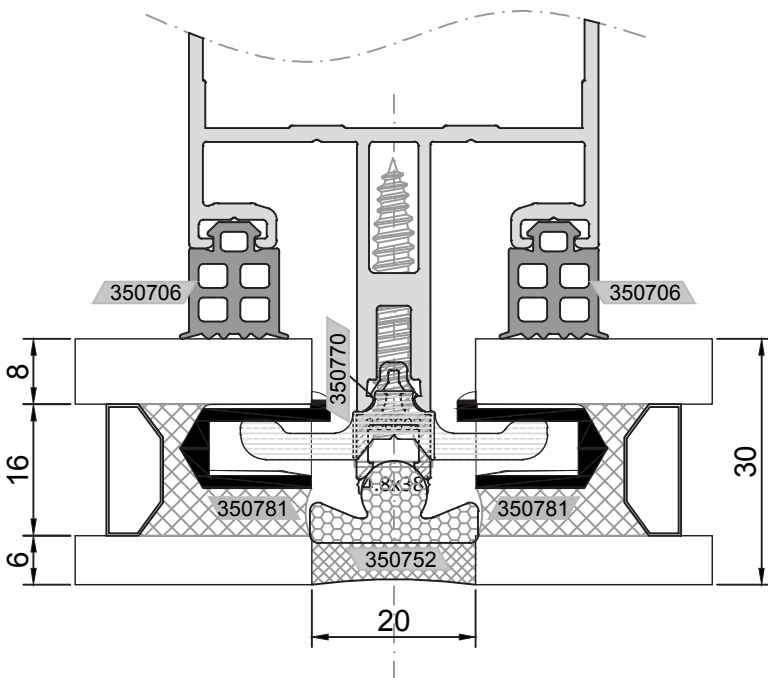

30,76mm

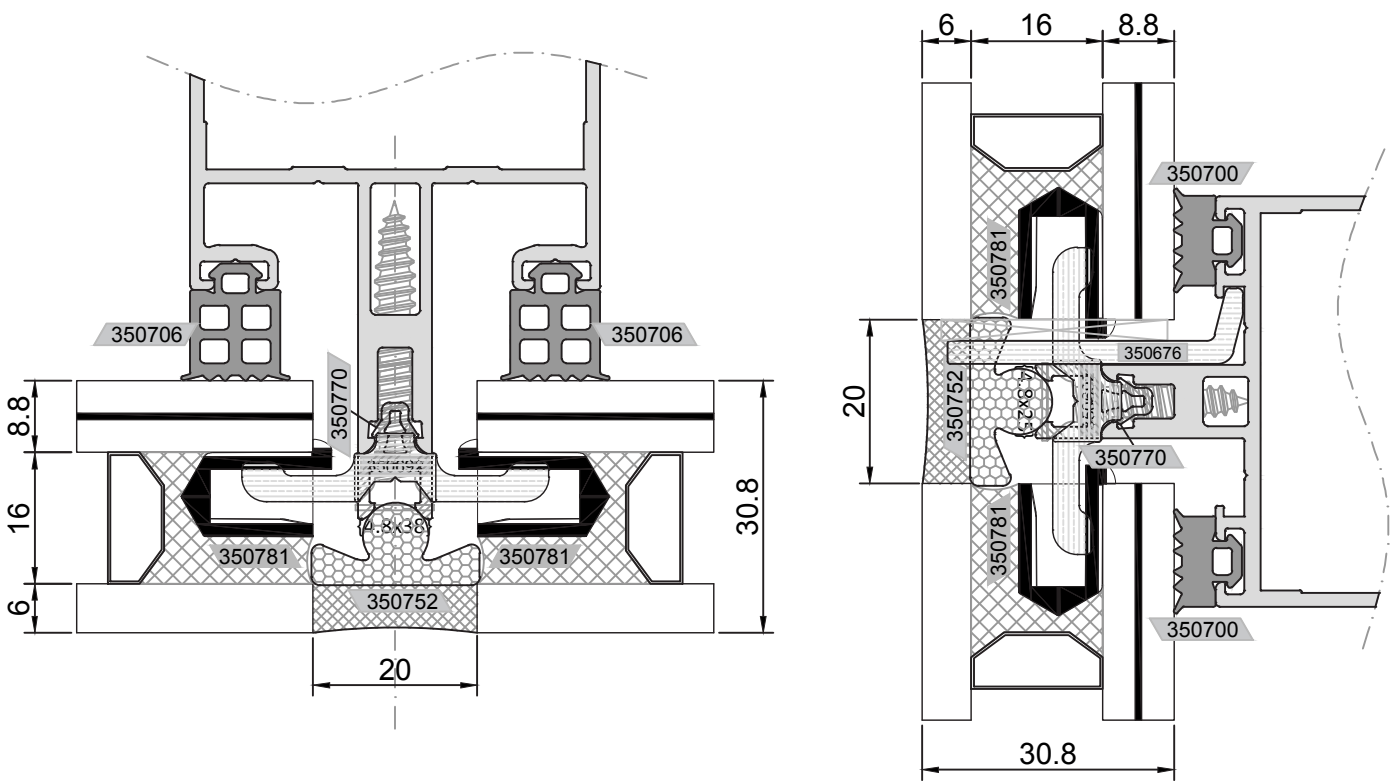

32mm

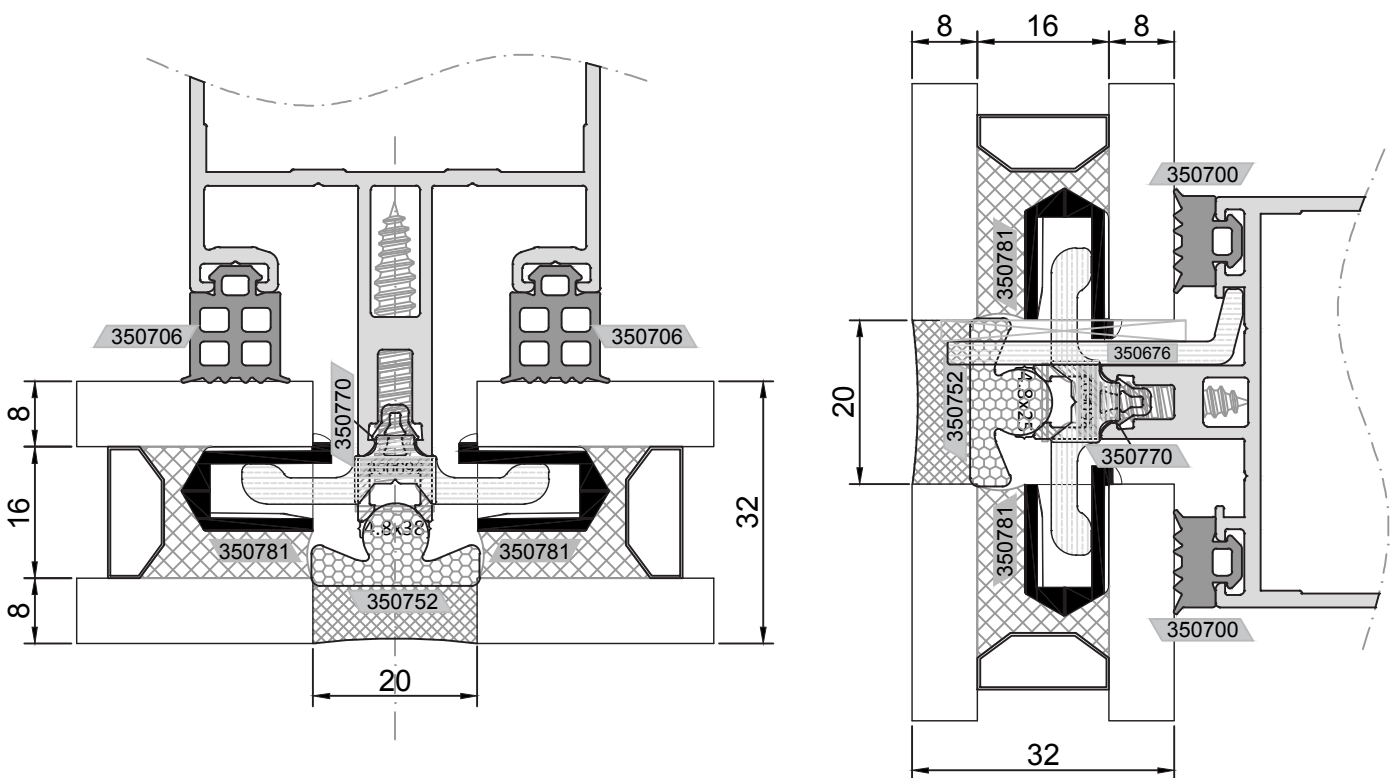

CAM KALINLIKLARINA GÖRE ENTEGRE SİSTEM DETAYLARI
INTEGRATED CURTAIN WALL DETAILS ACCORDING TO THE GLASS THICKNESSES

32,76mm

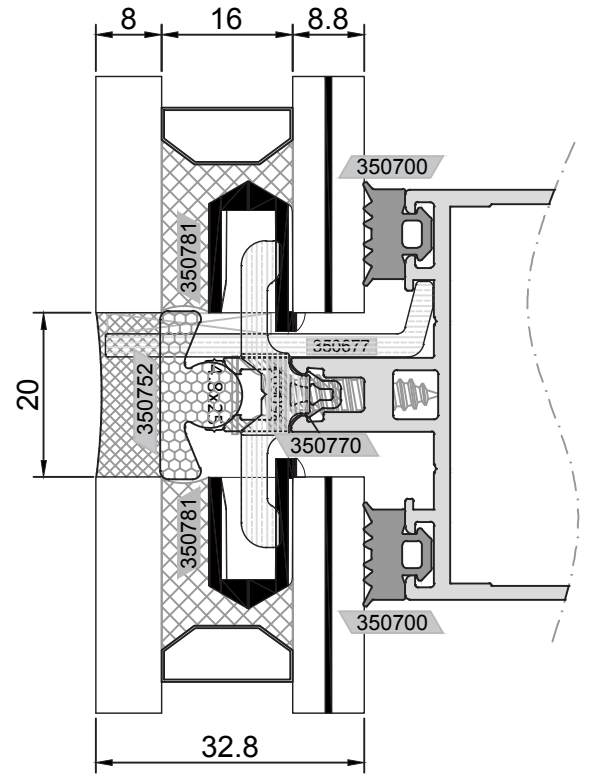
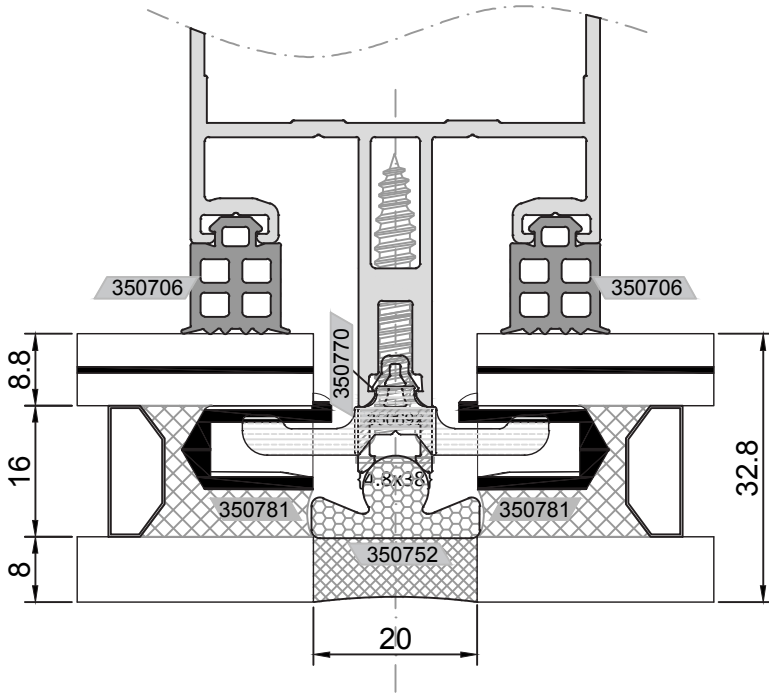

32,76mm

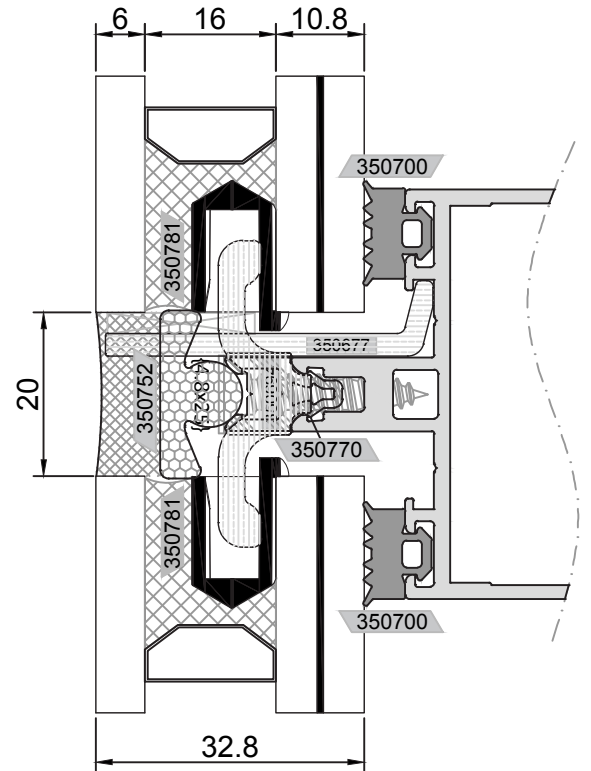
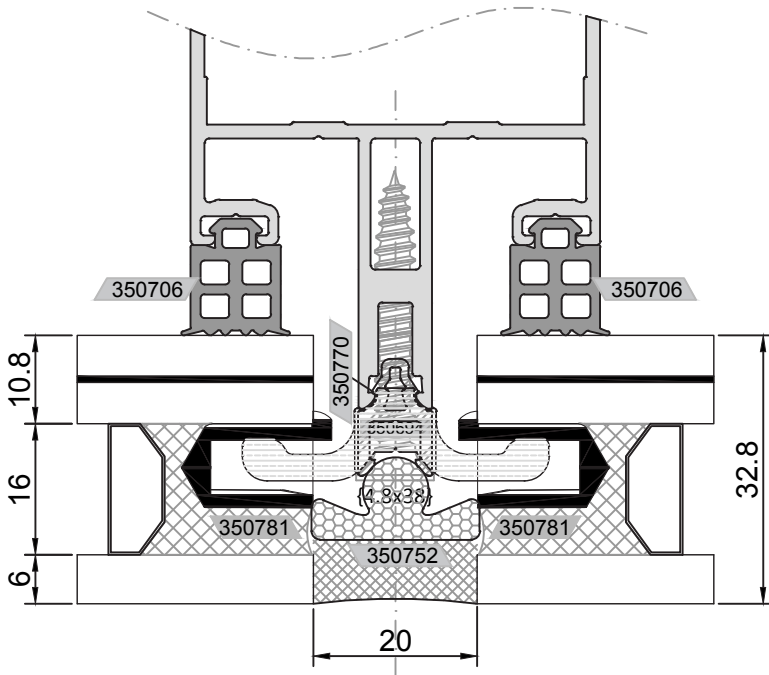

33,52mm

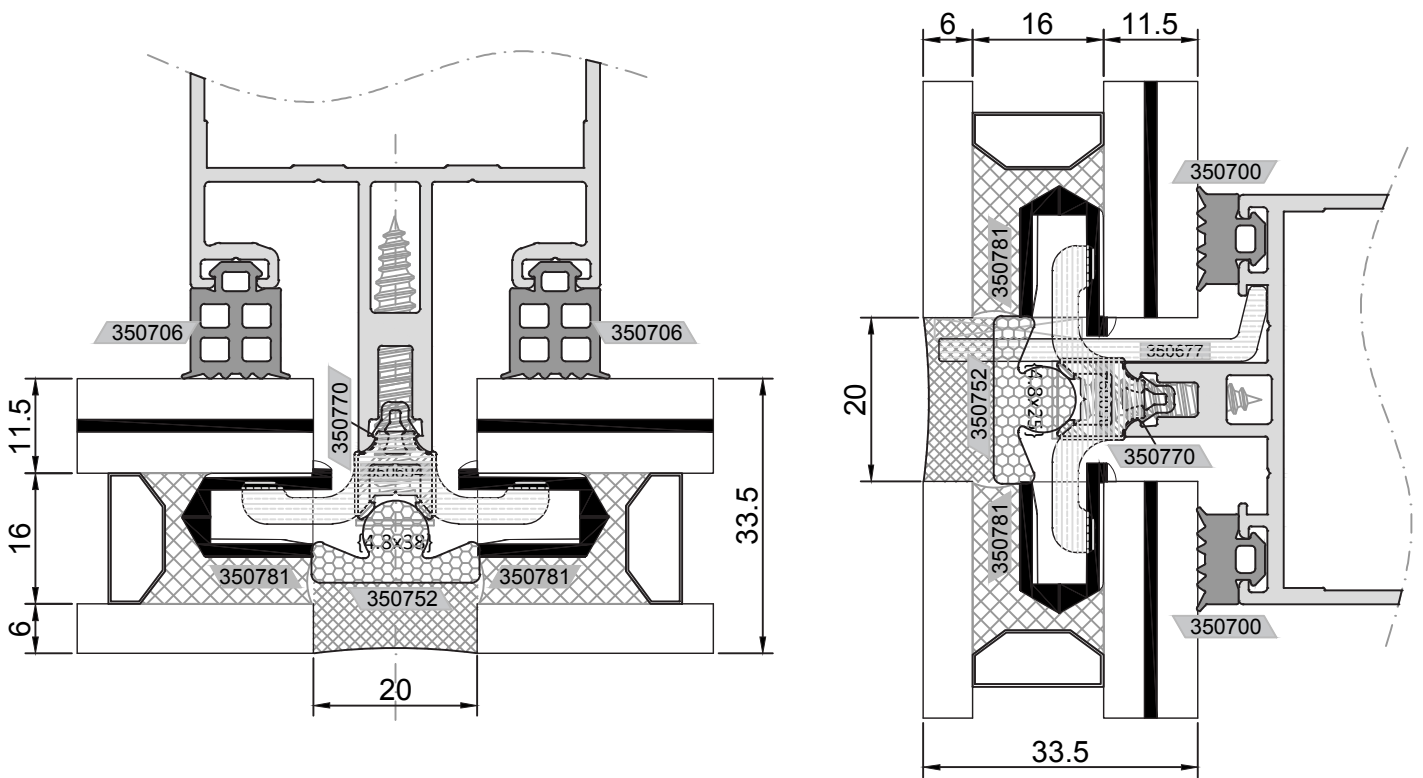

34,76mm

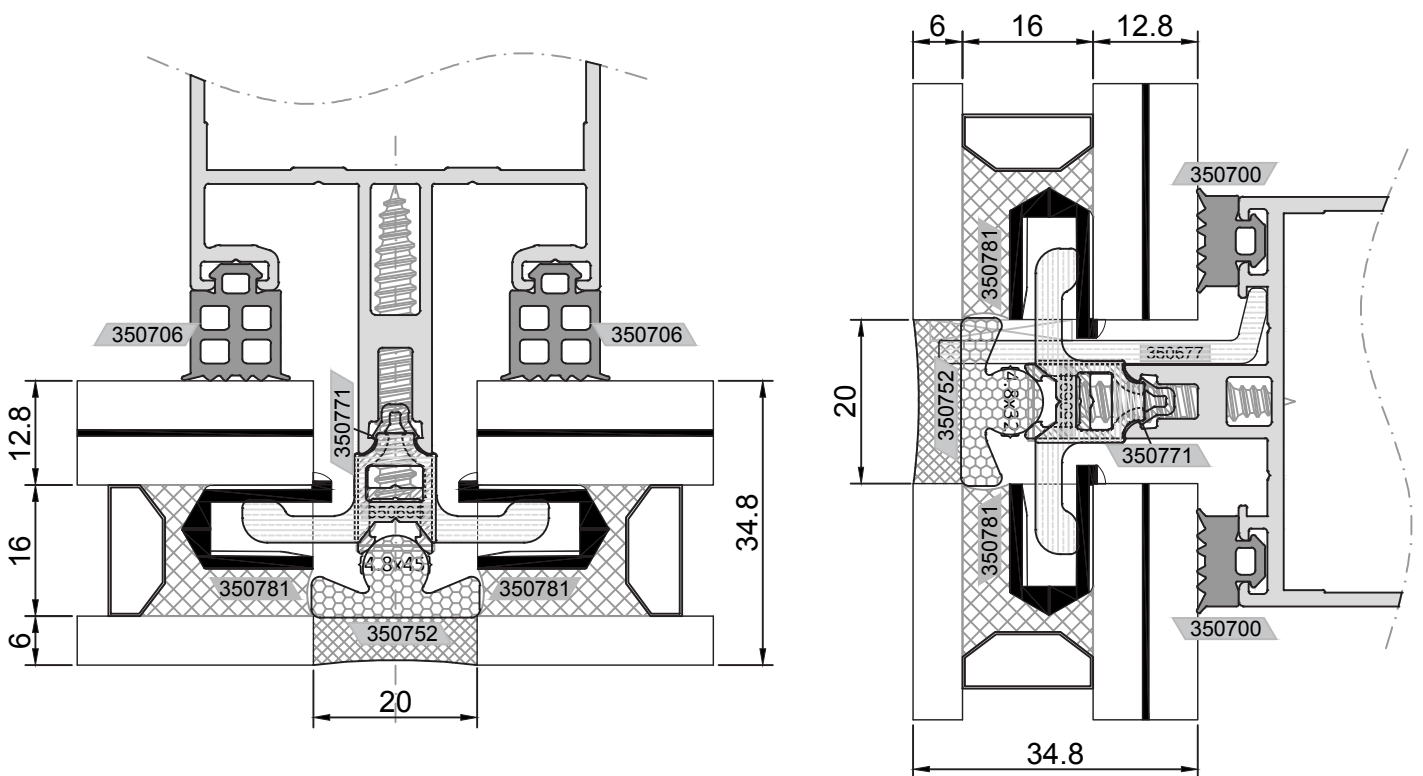

35,52mm

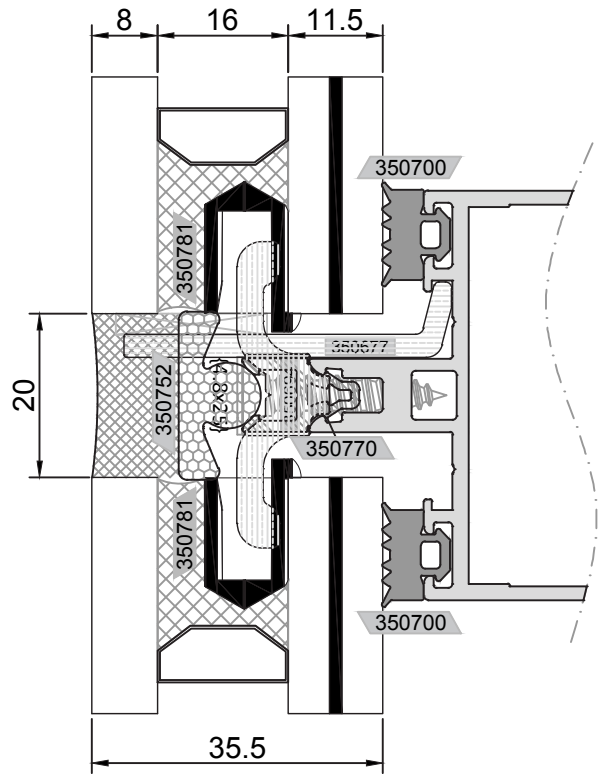
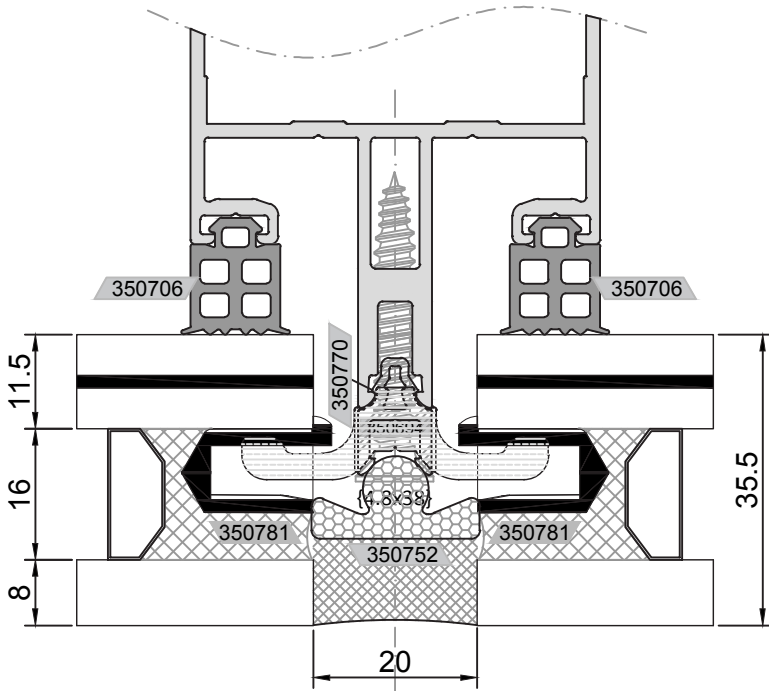

35,52mm

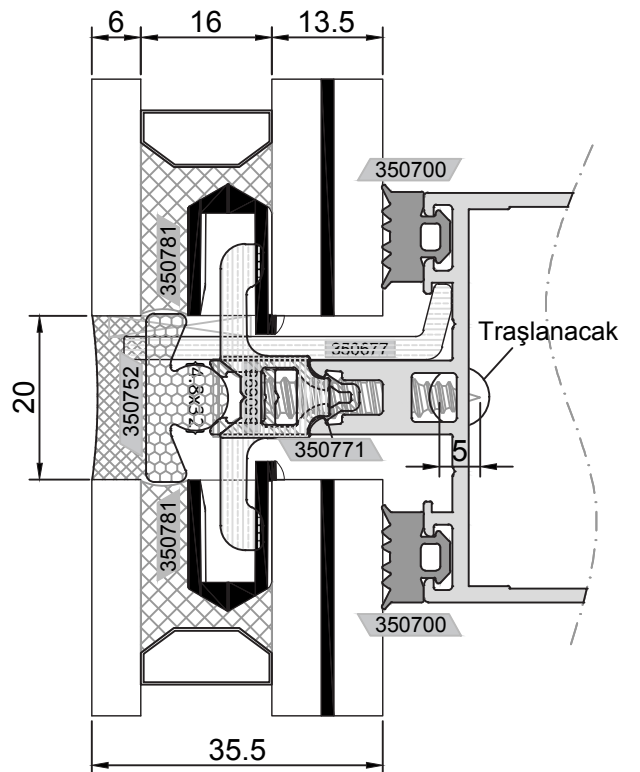
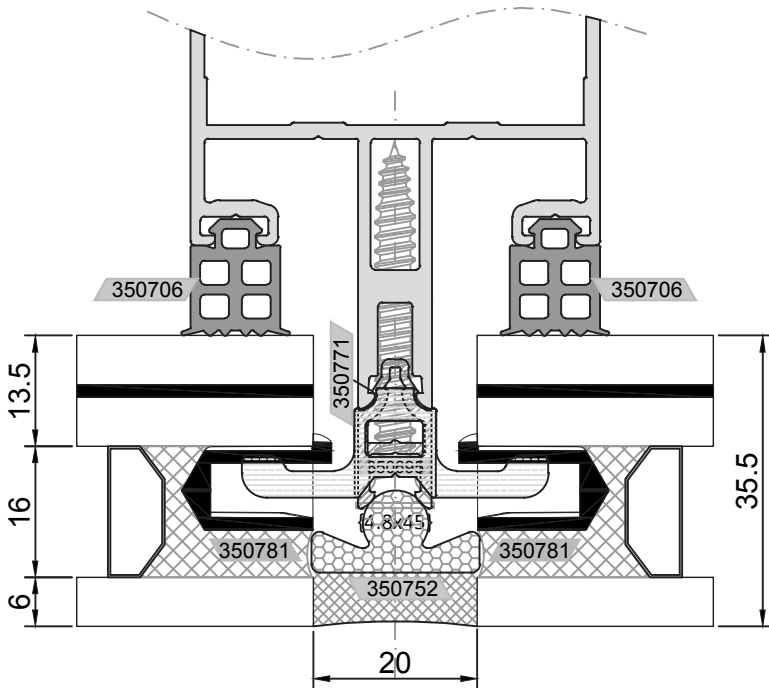

36,76mm

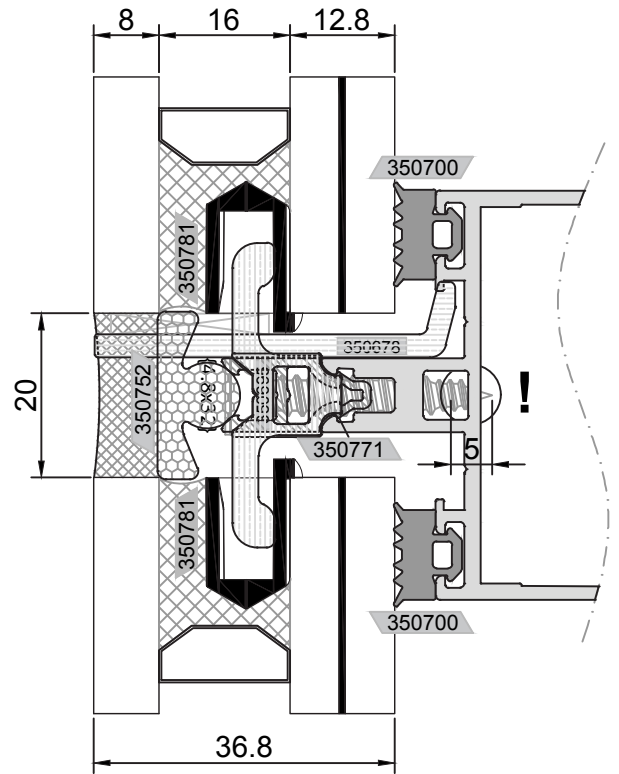
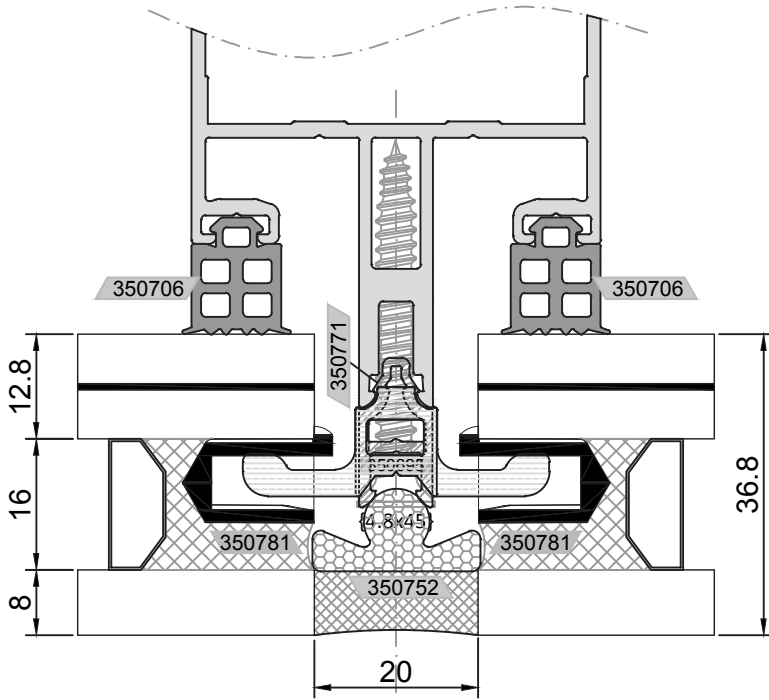

37,52mm

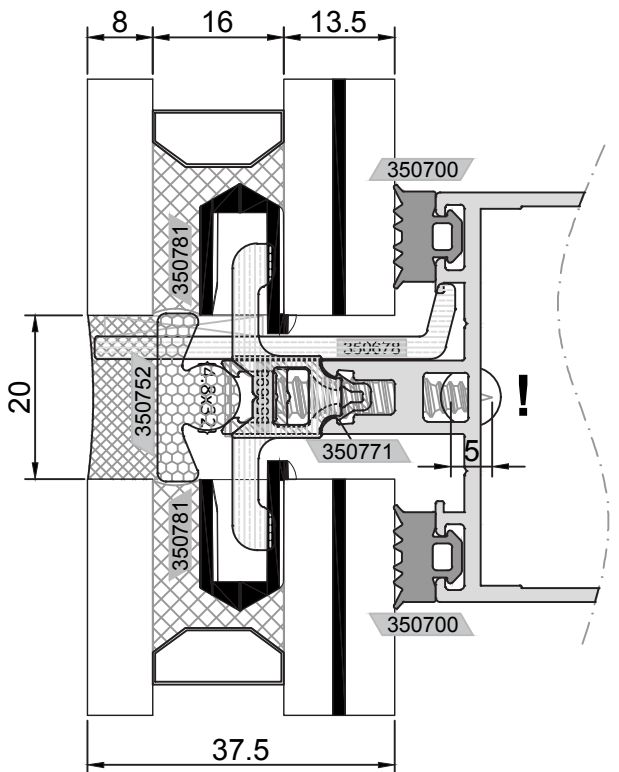
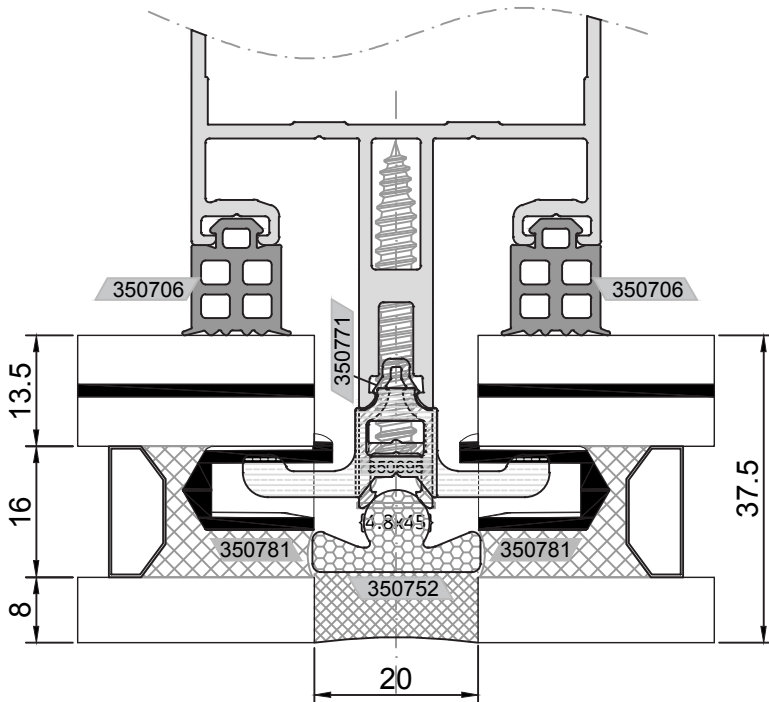

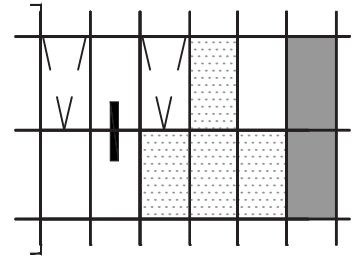

YATAY DETAYI
HORIZONTAL DETAIL

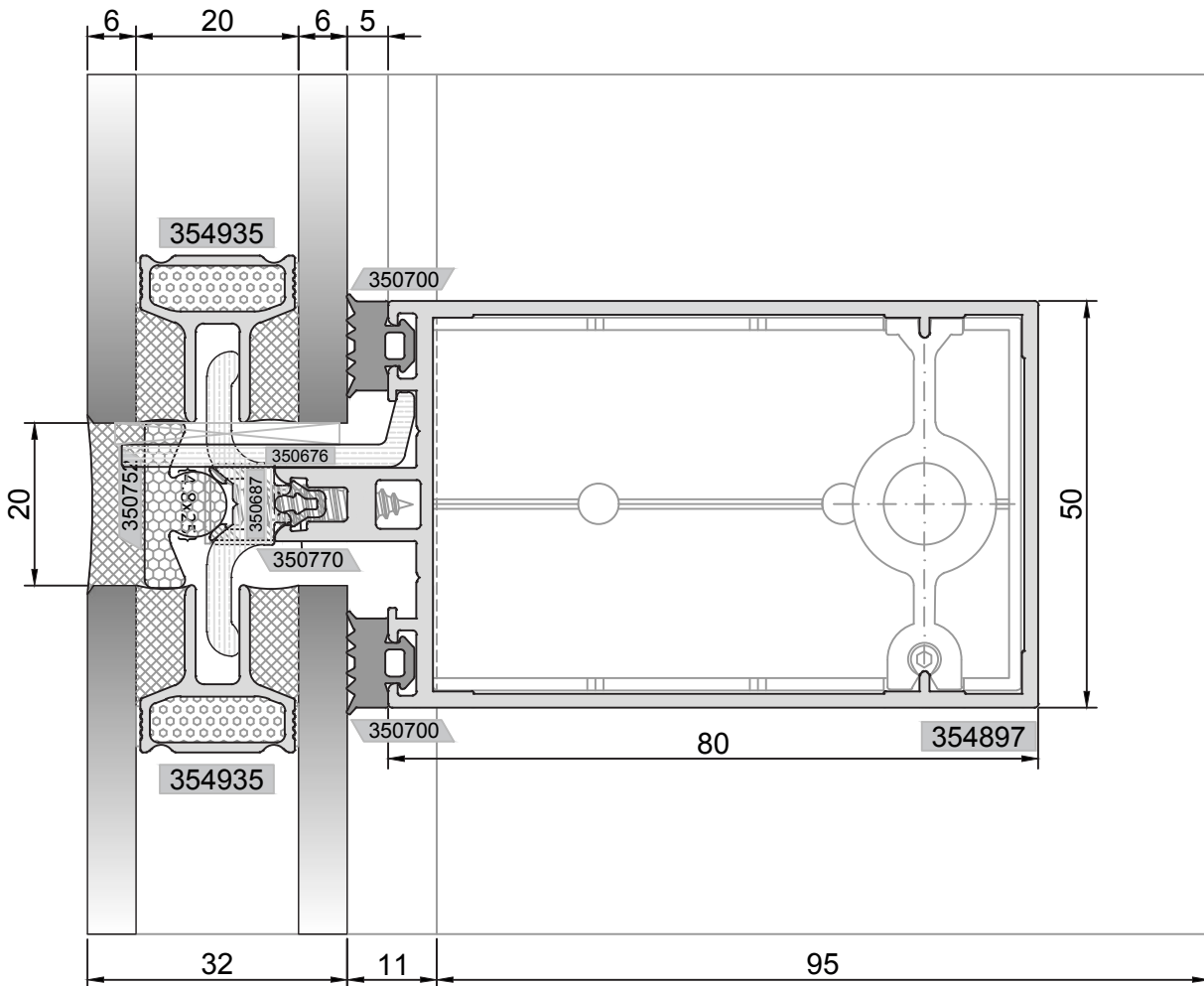

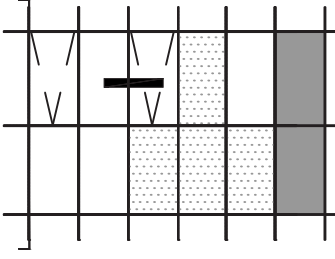

DÜŞEY DETAYI
VERTICAL DETAIL

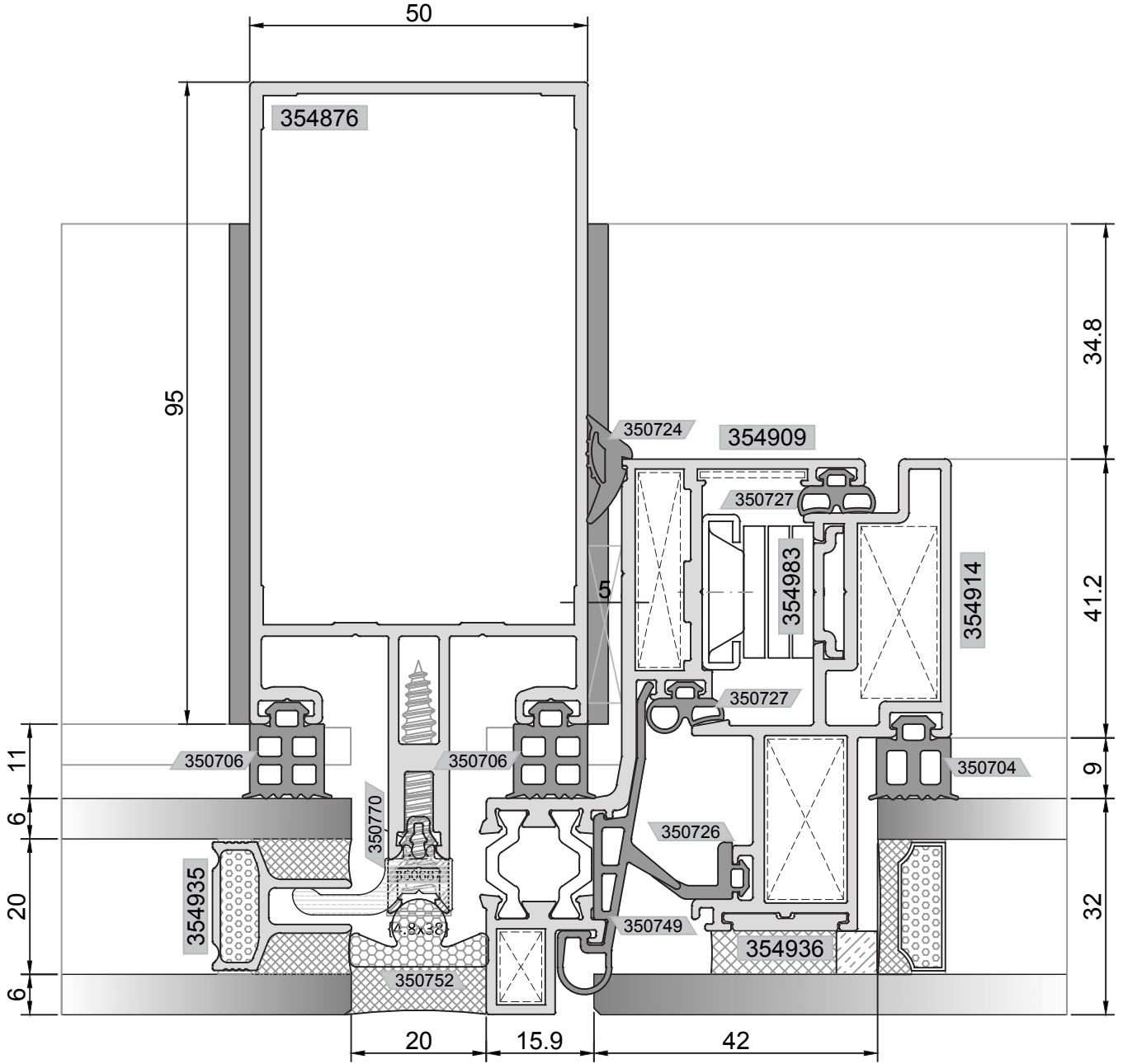

ALTERNATİF 1: YALITIMSIZ KANAT DETAYI
ALTERNATIVE 1 : UNINSULATED VENT DETAIL

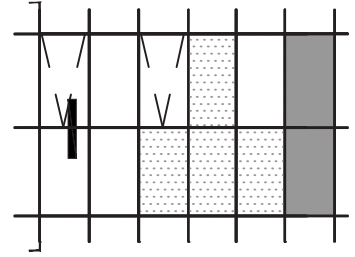

YATAY DETAYI
HORIZONTAL DETAIL

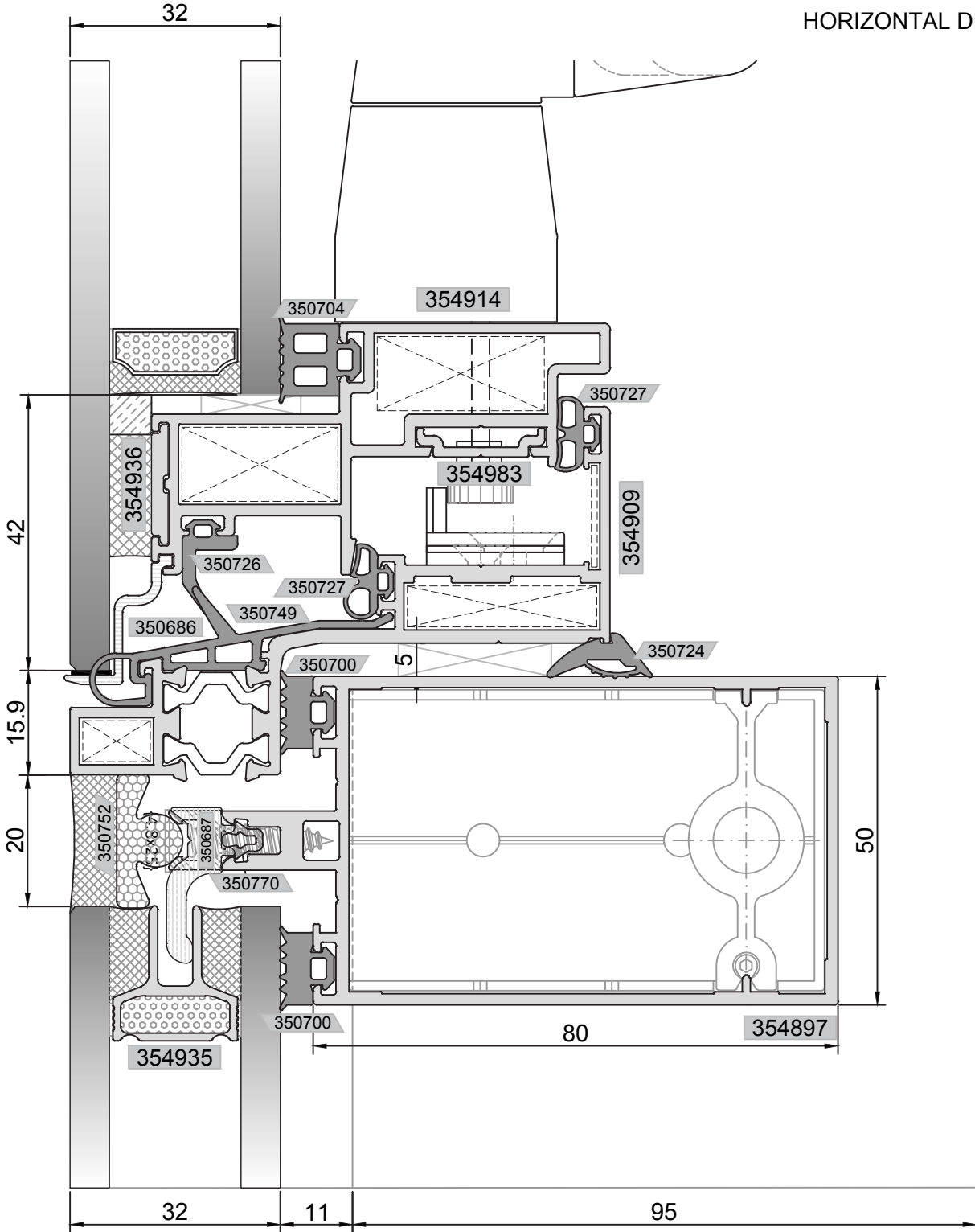

ALTERNATİF 1: YALITIMSIZ KANAT DETAYI
ALTERNATIVE 1 : UNINSULATED VENT DETAIL

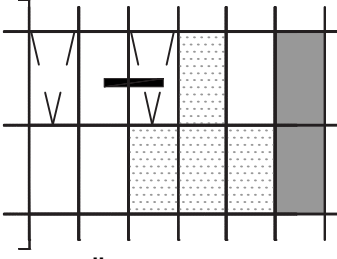

DÜŞEY DETAYI
VERTICAL DETAIL

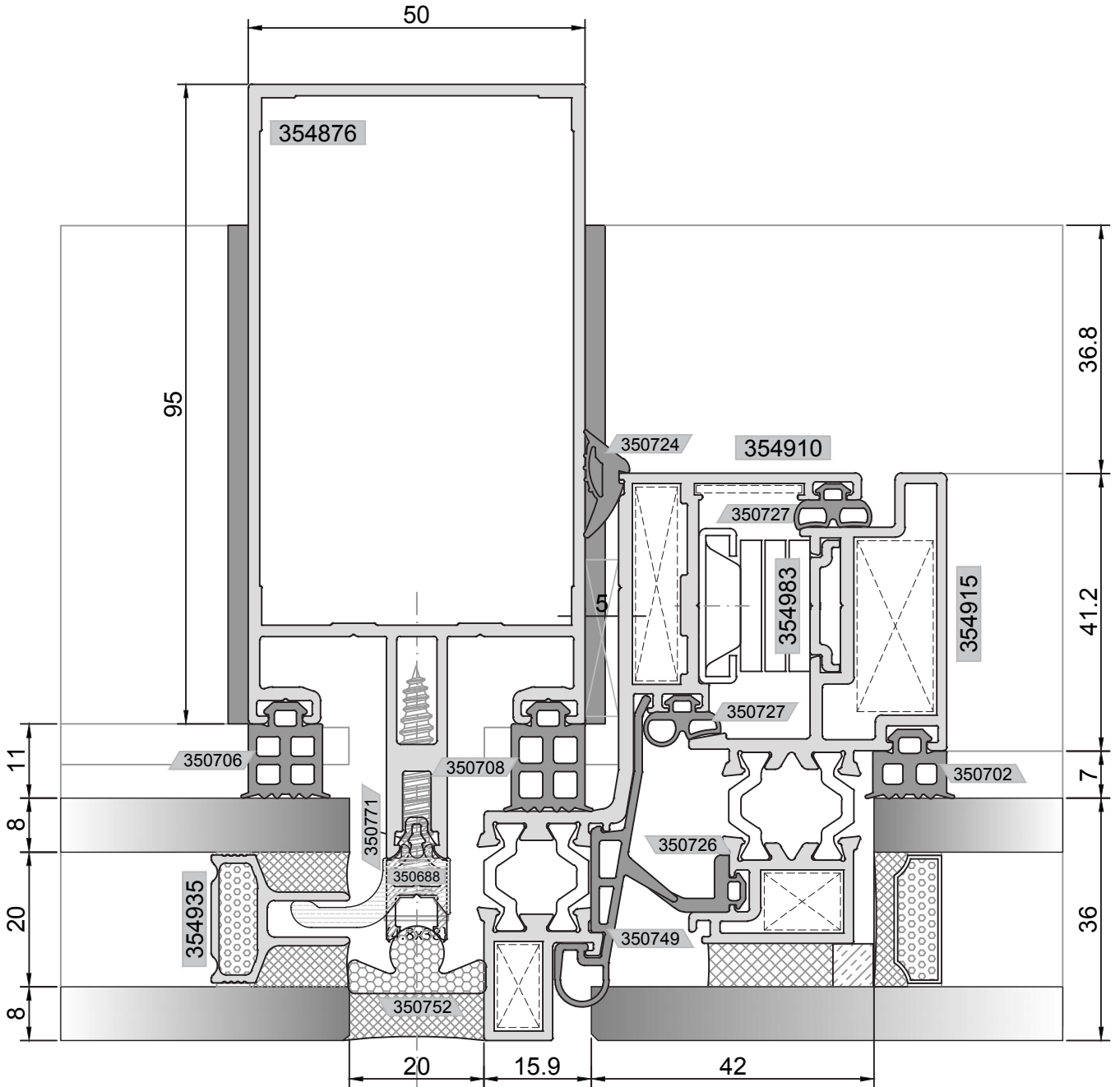

ALTERNATİF 2: YALITIMLI KANAT DETAYI
ALTERNATIVE 2 : INSULATED VENT DETAIL

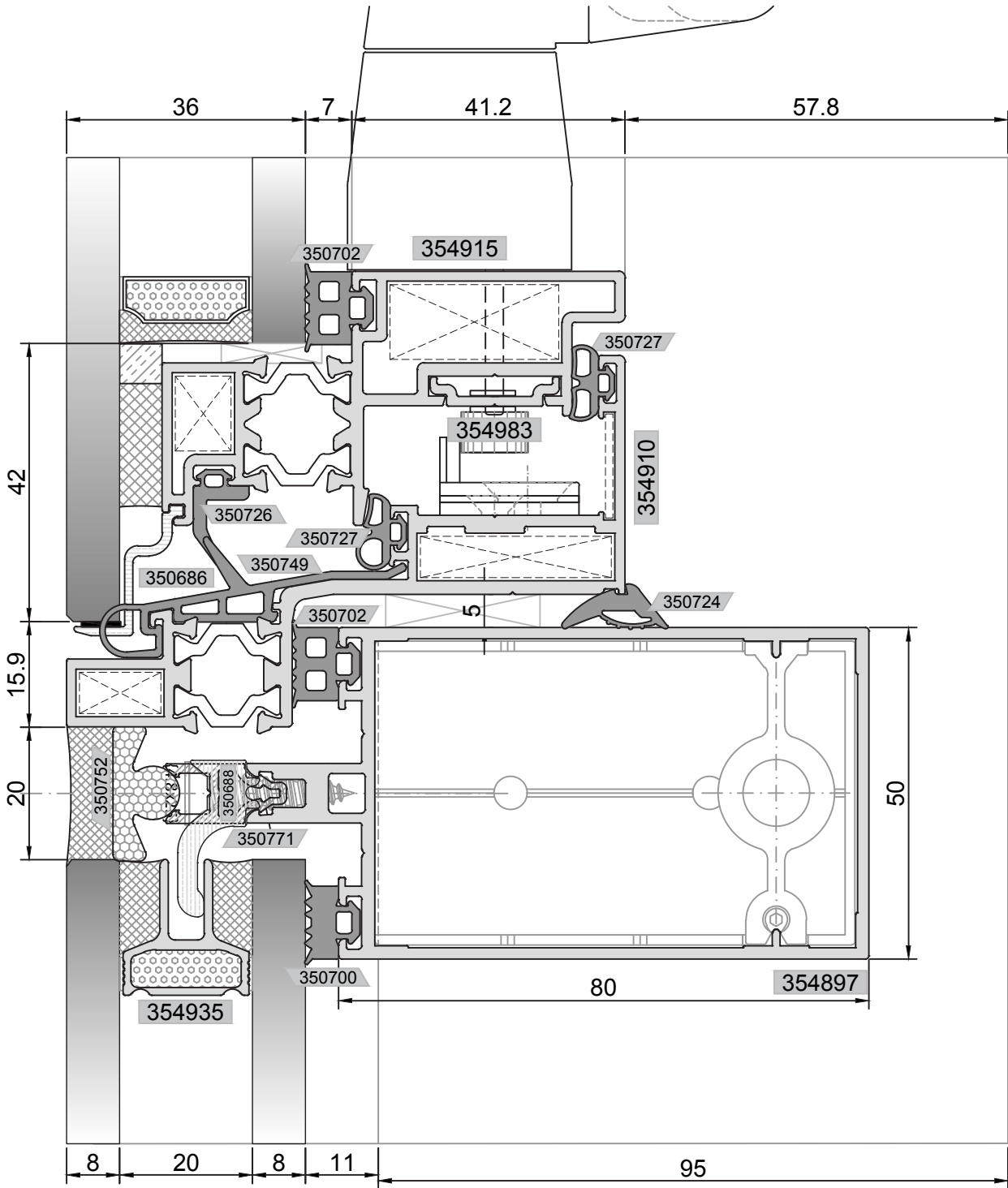
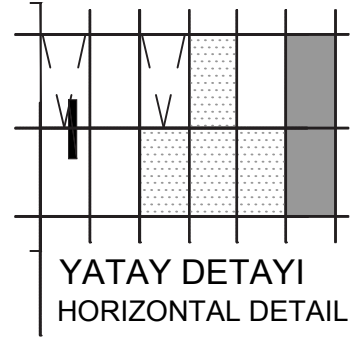

ALTERNATİF 2: YALITIMLI KANAT DETAYI
ALTERNATIVE 2 : INSULATED VENT DETAIL

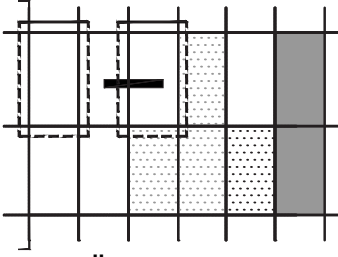

DÜŞEY DETAYI
VERTICAL DETAIL

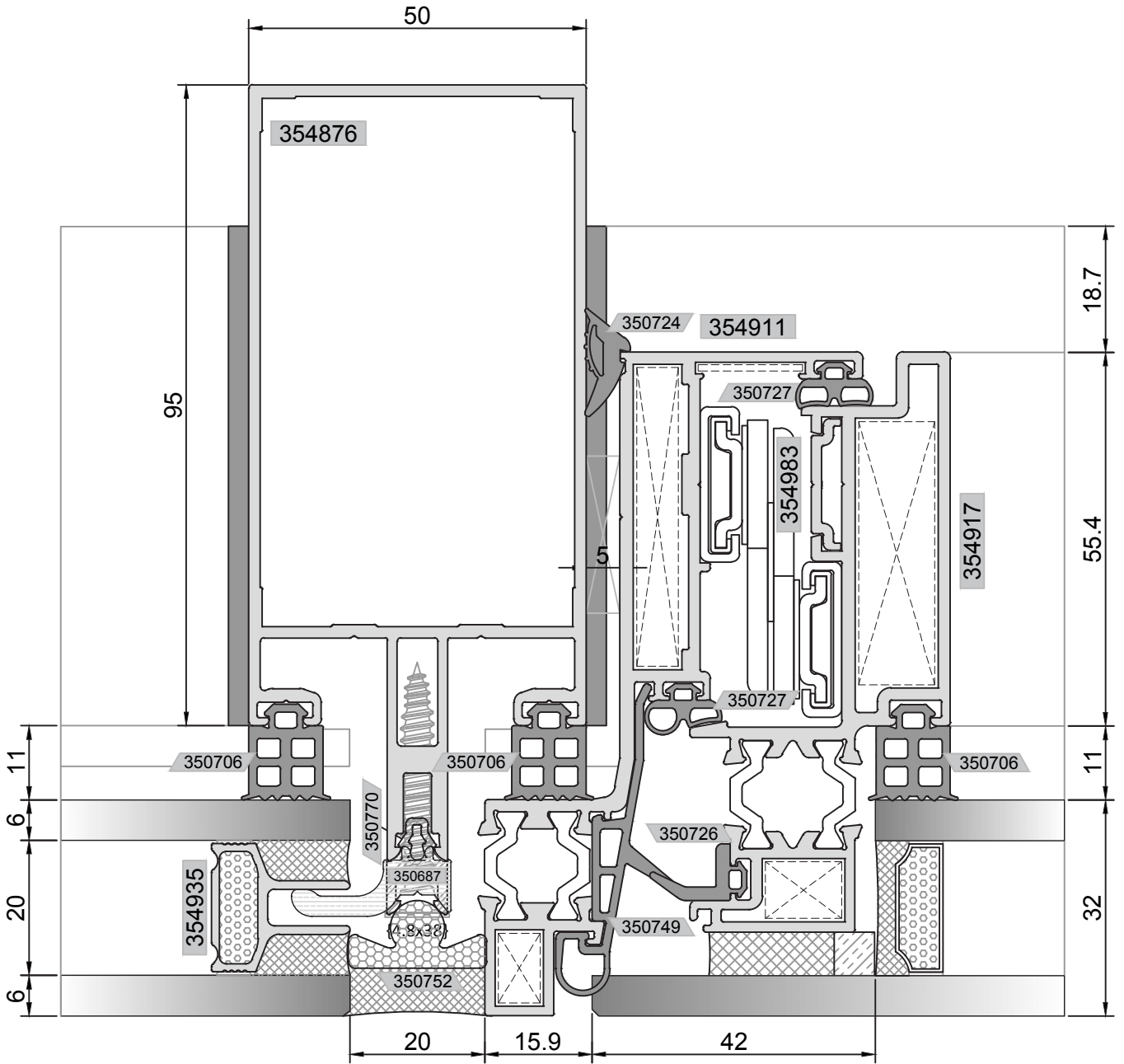

ALTERNATİF 1: YALITIMLI PARALEL AÇILIR KANAT DETAYI
ALTERNATIVE 1 : PARALEL OPENING INSULATED VENT DETAIL

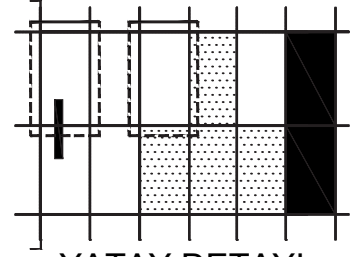

YATAY DETAYI
HORIZONTAL DETAIL

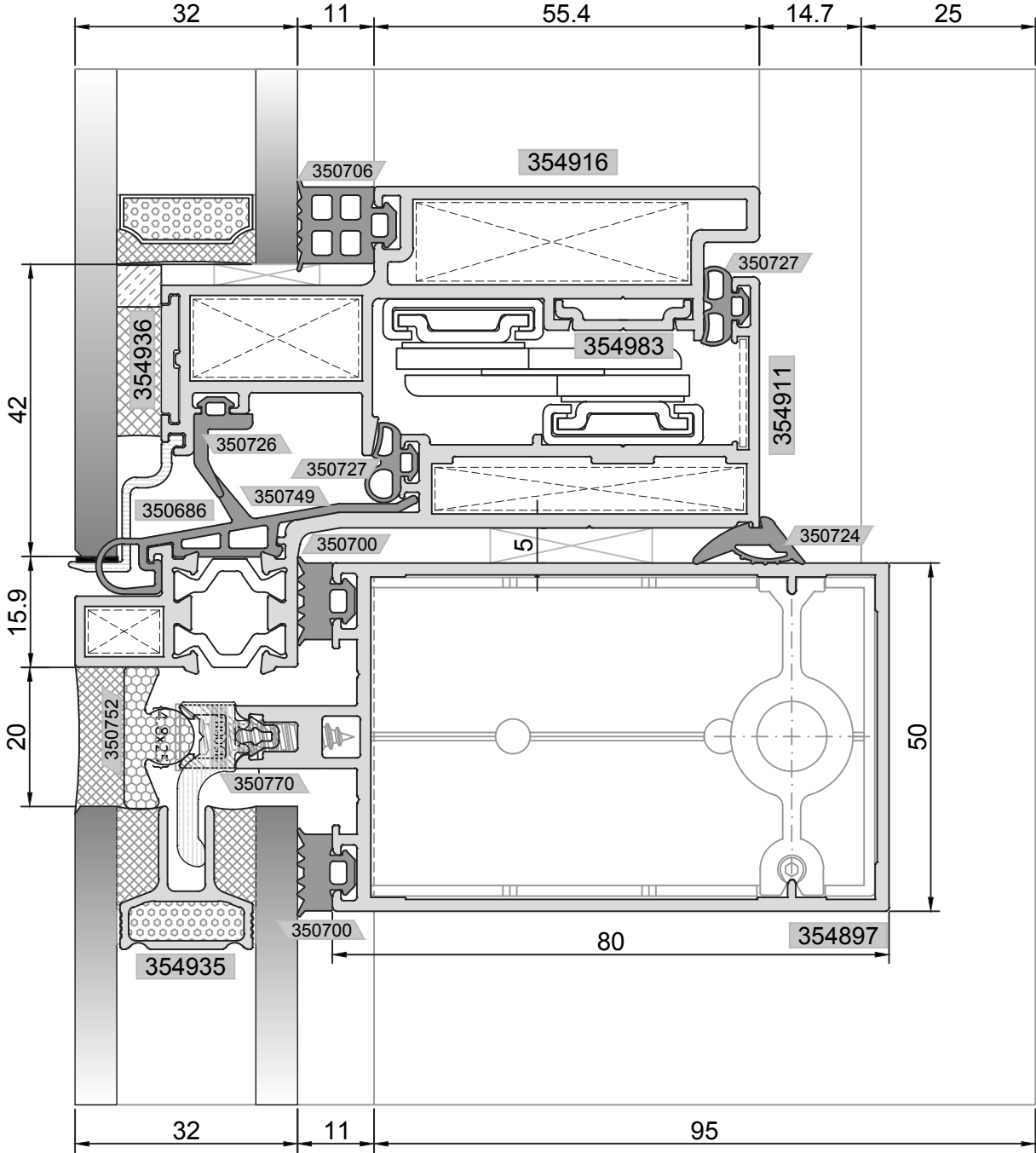

ALTERNATİF 2: YALITIMSIZ PARALEL AÇILIR KANAT DETAYI
ALTERNATIVE 2 : PARALEL OPENING UNINSULATED VENT DETAIL

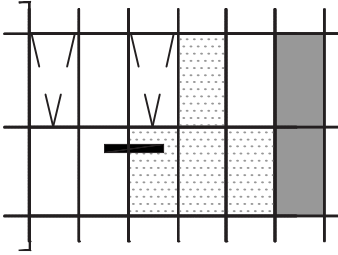

DÜŞEY DETAYI
VERTICAL DETAIL

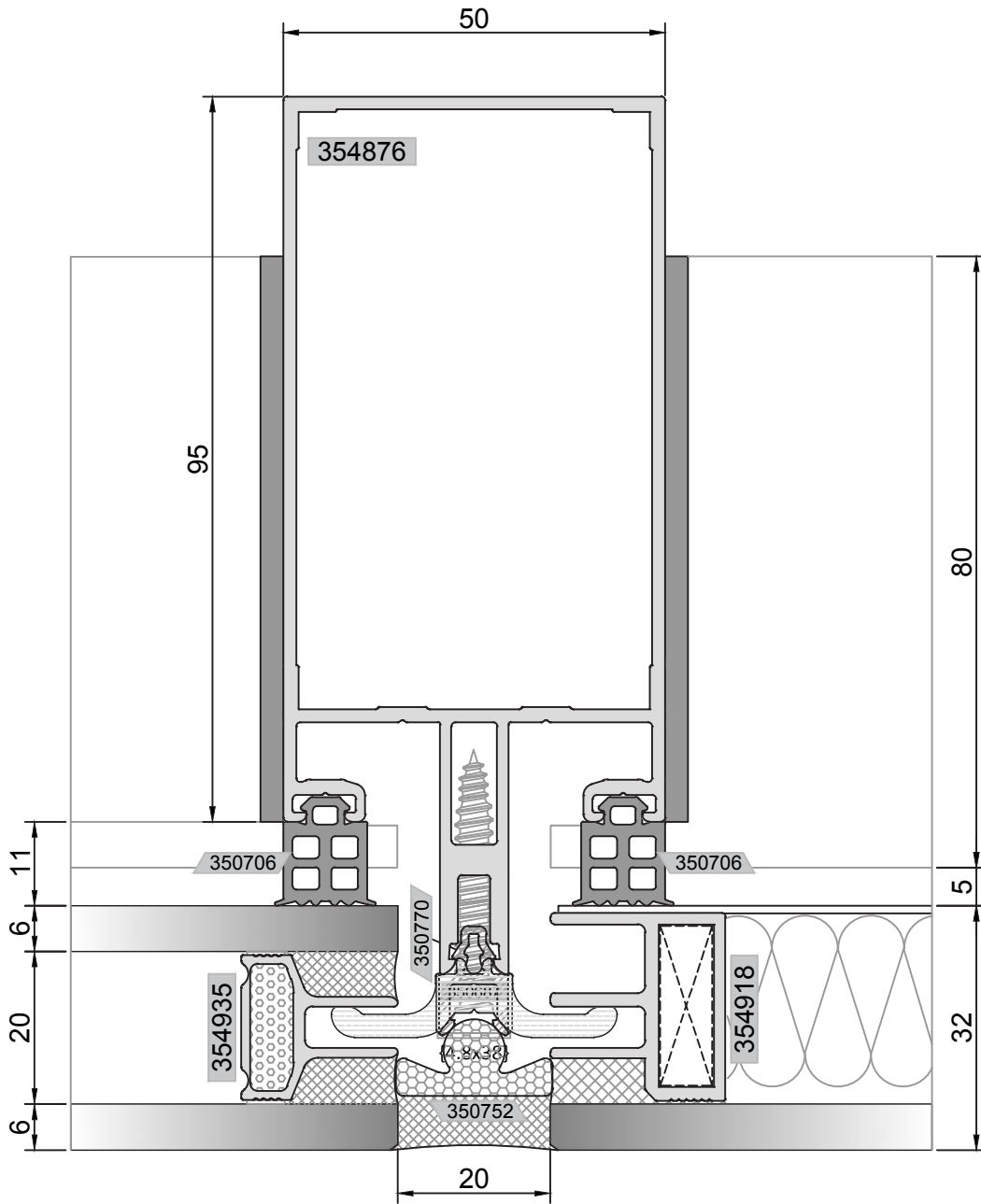

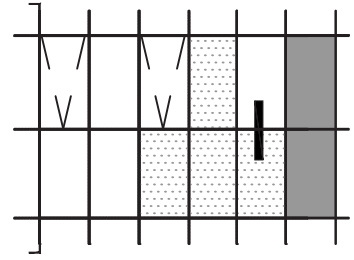

YATAY DETAYI
HORIZONTAL DETAIL

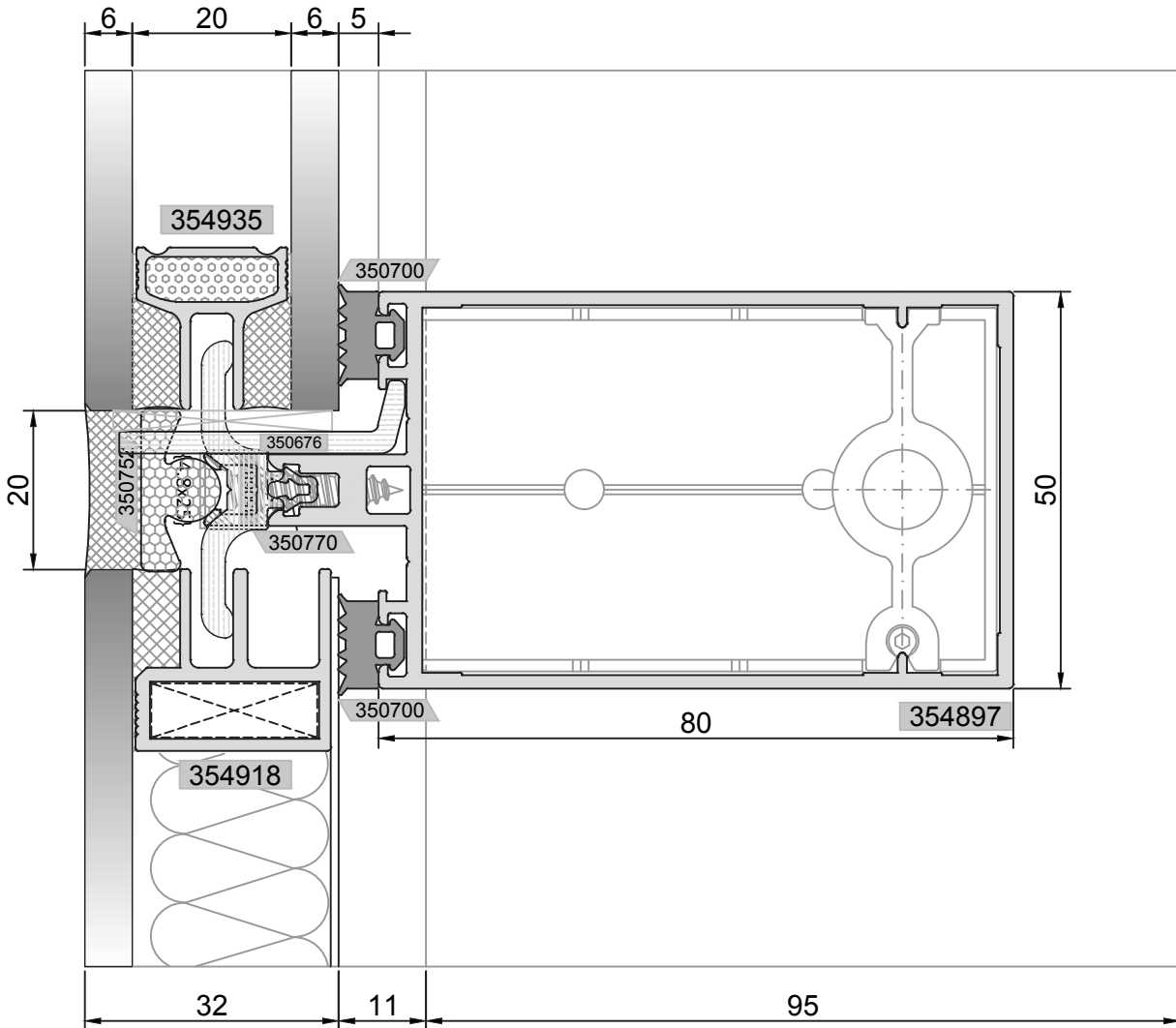

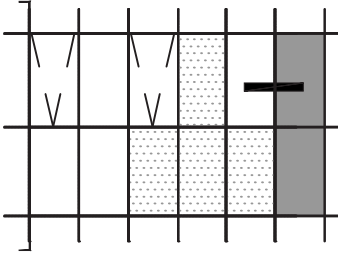

DÜŞEY DETAYI
VERTICAL DETAIL

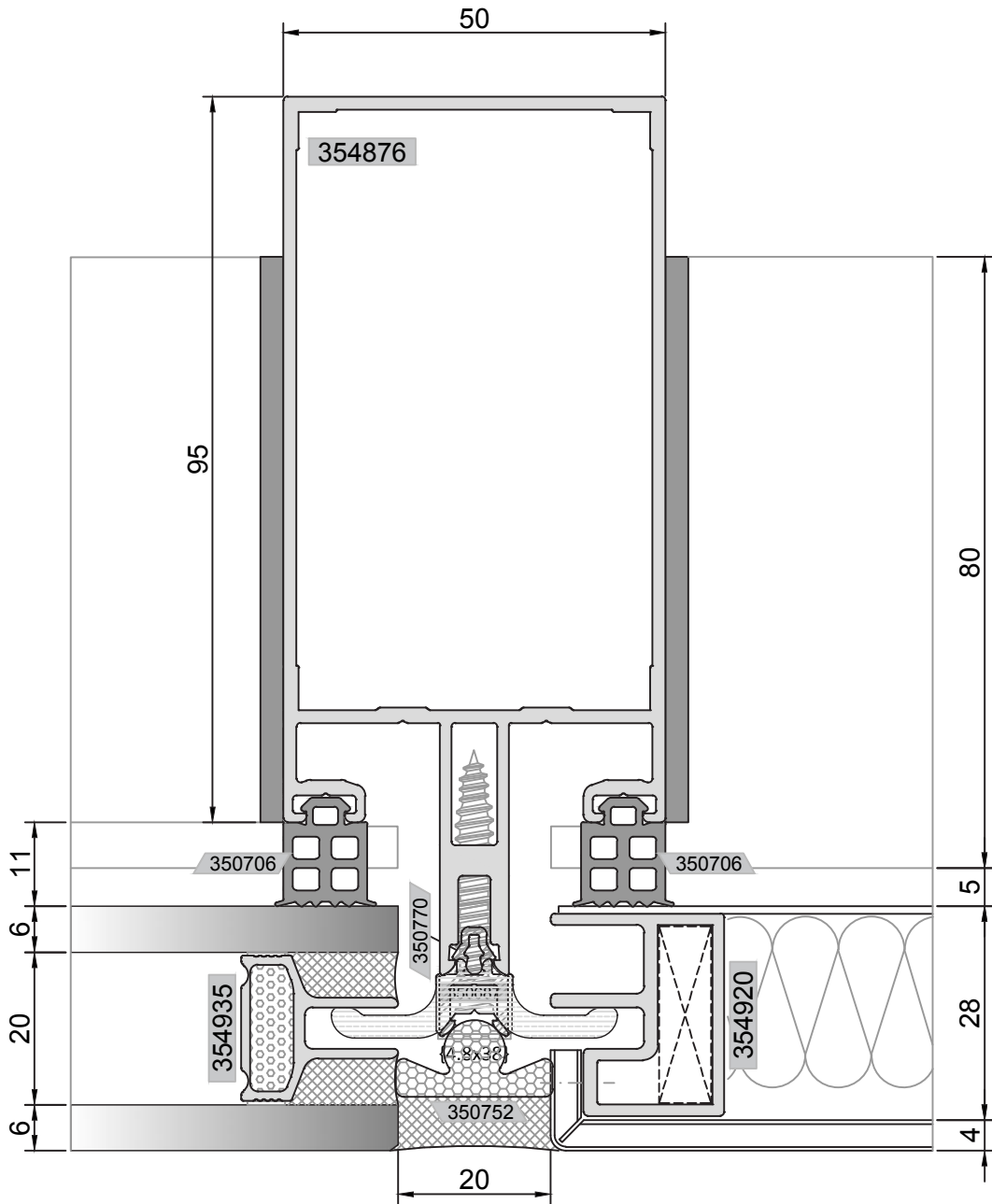

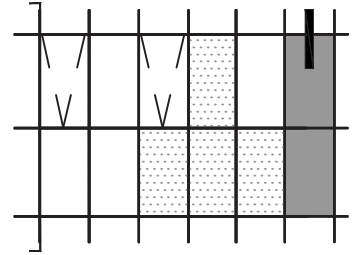

YATAY DETAYI
HORIZONTAL DETAIL

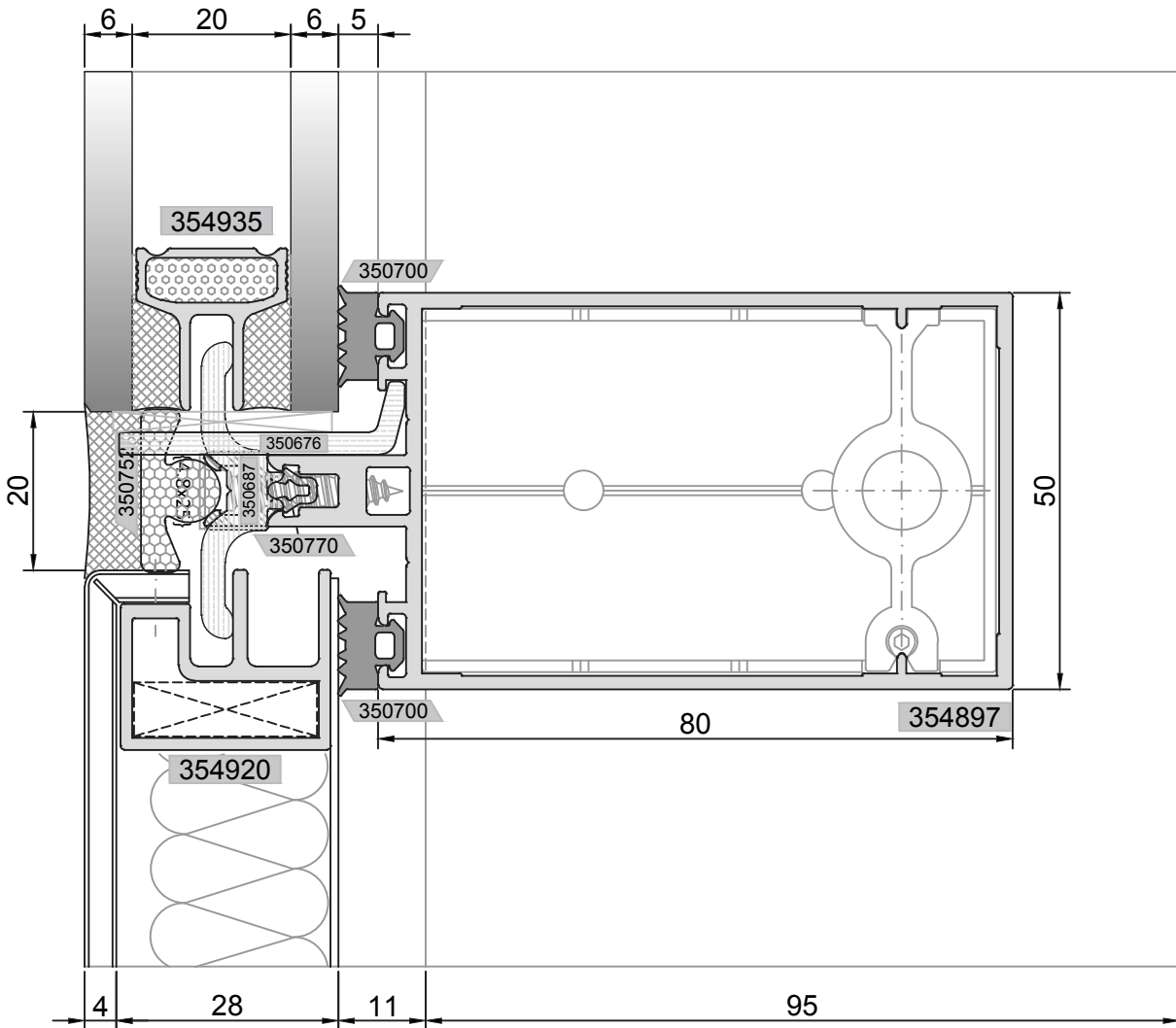

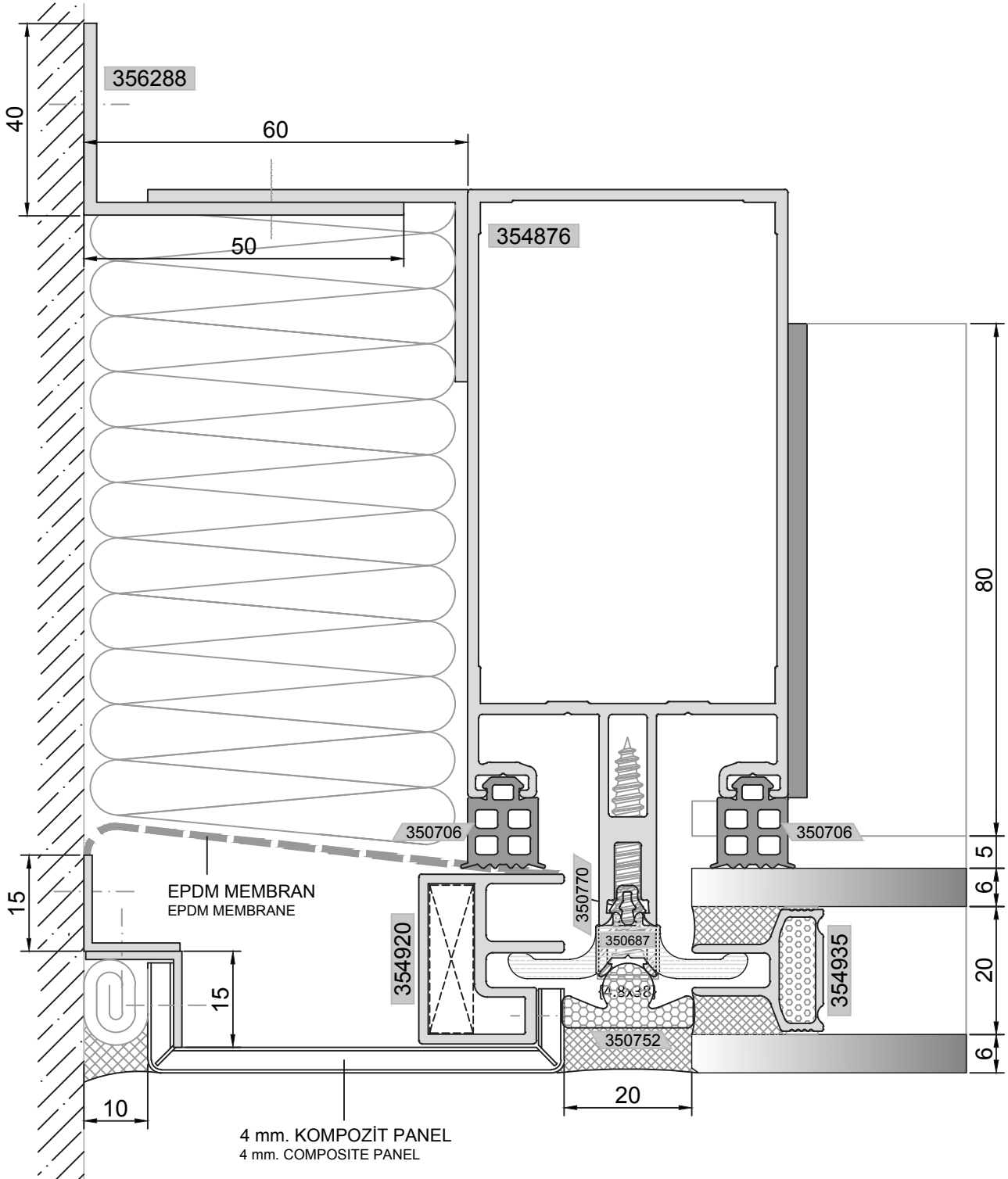
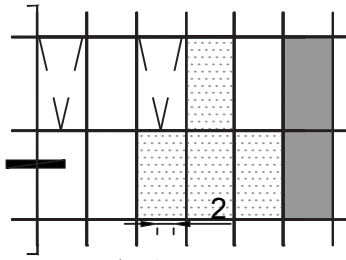

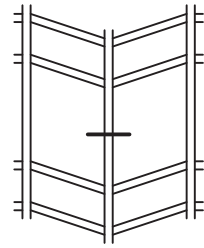

0° - 10°

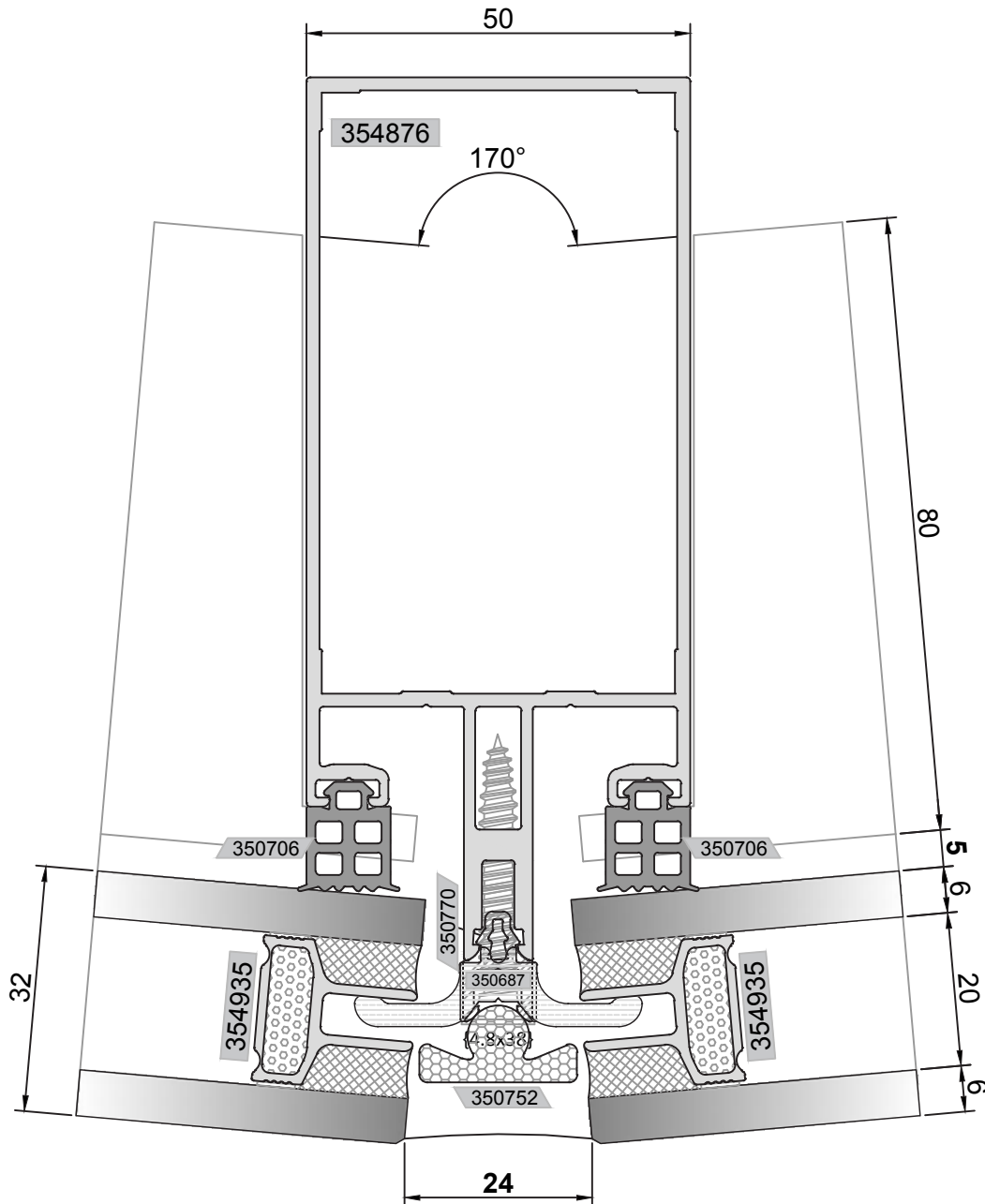

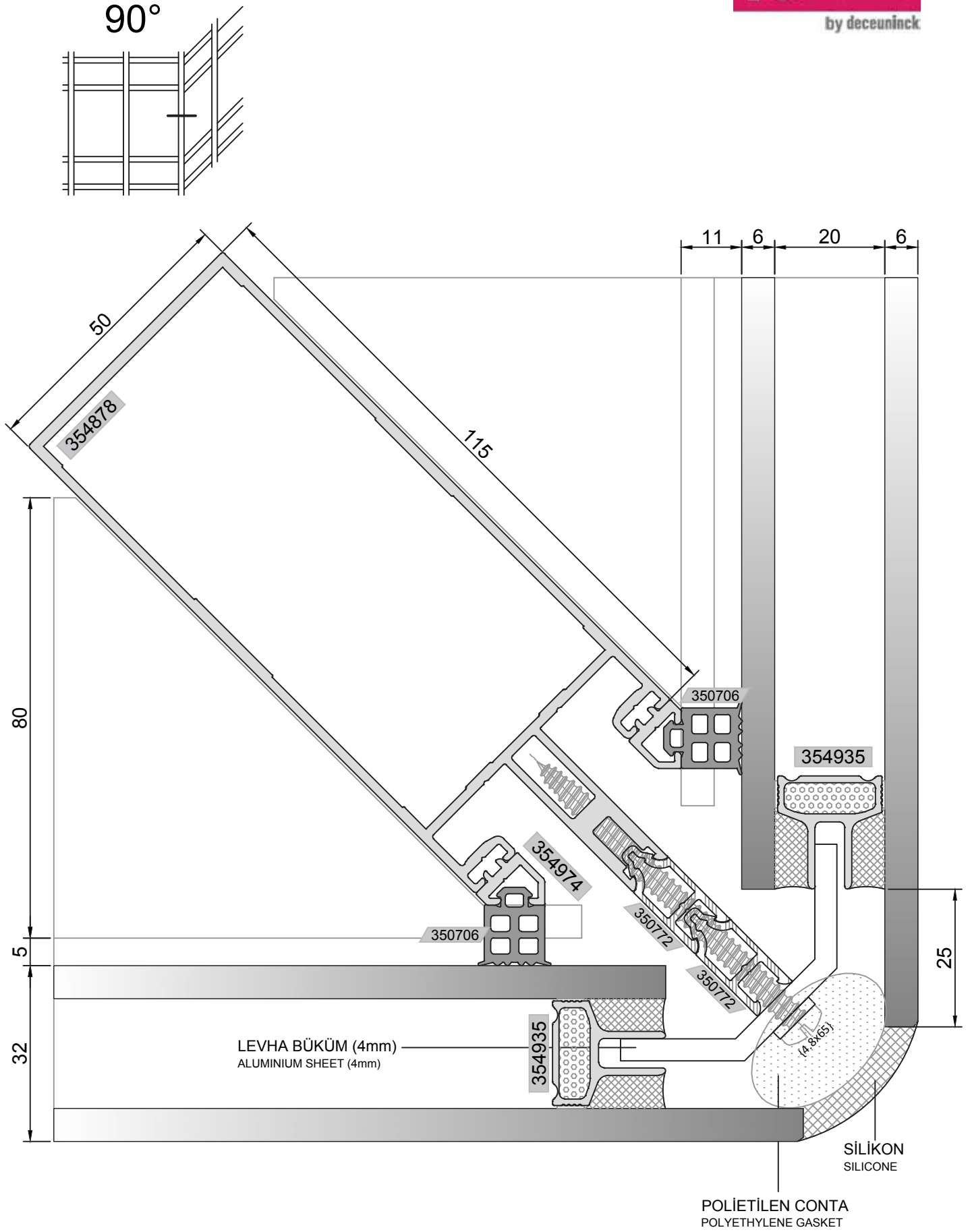

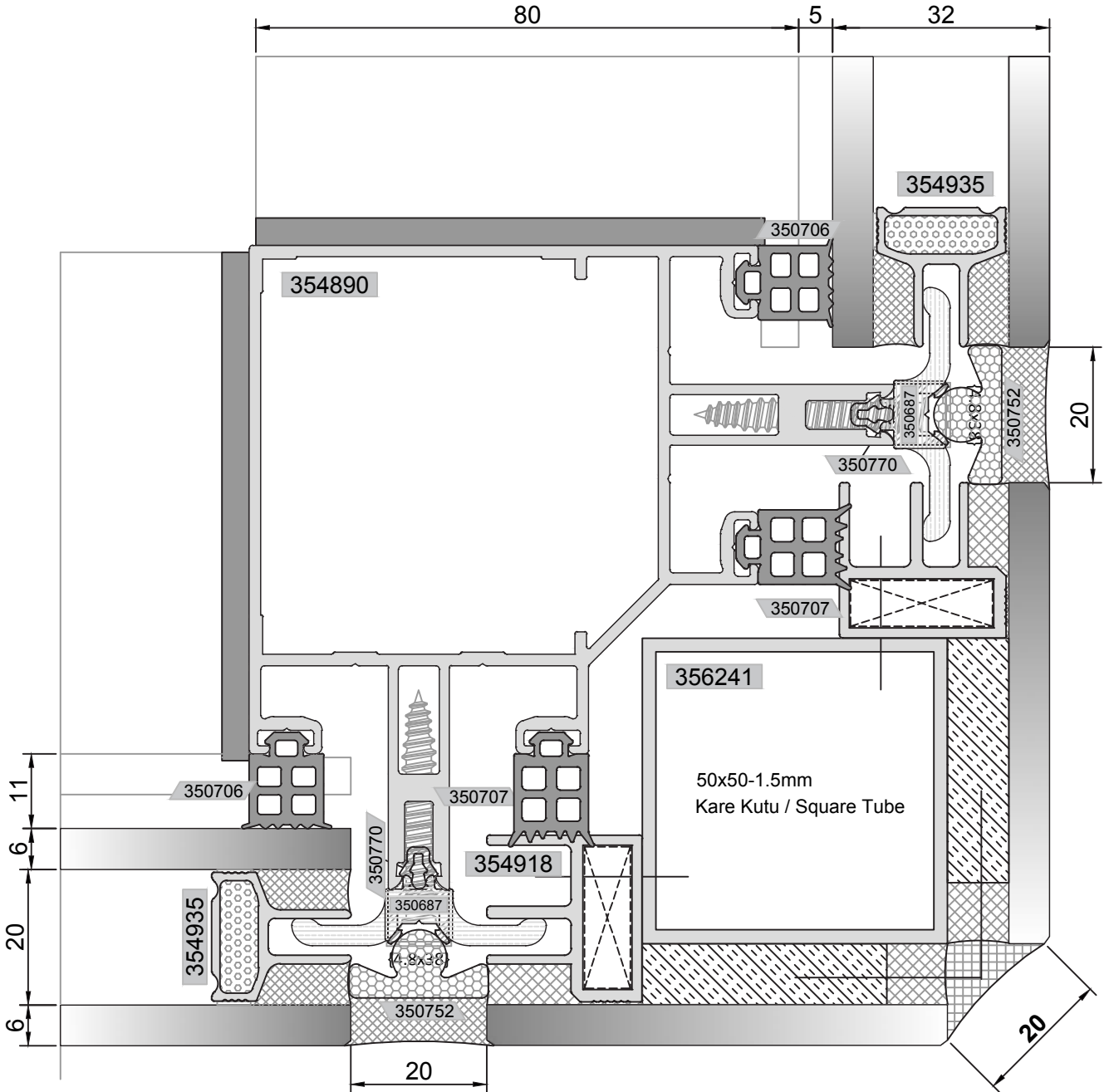
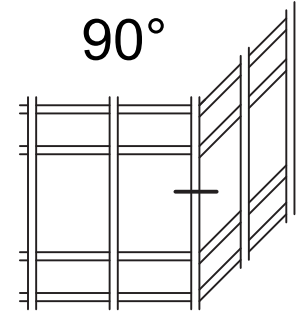

ALTERNATİF 2: ÇİFT DİKMELİ KÖŞE DETAYI
ALTERNATIVE 2 : CORNER DETAIL WITH DOUBLE MULLION

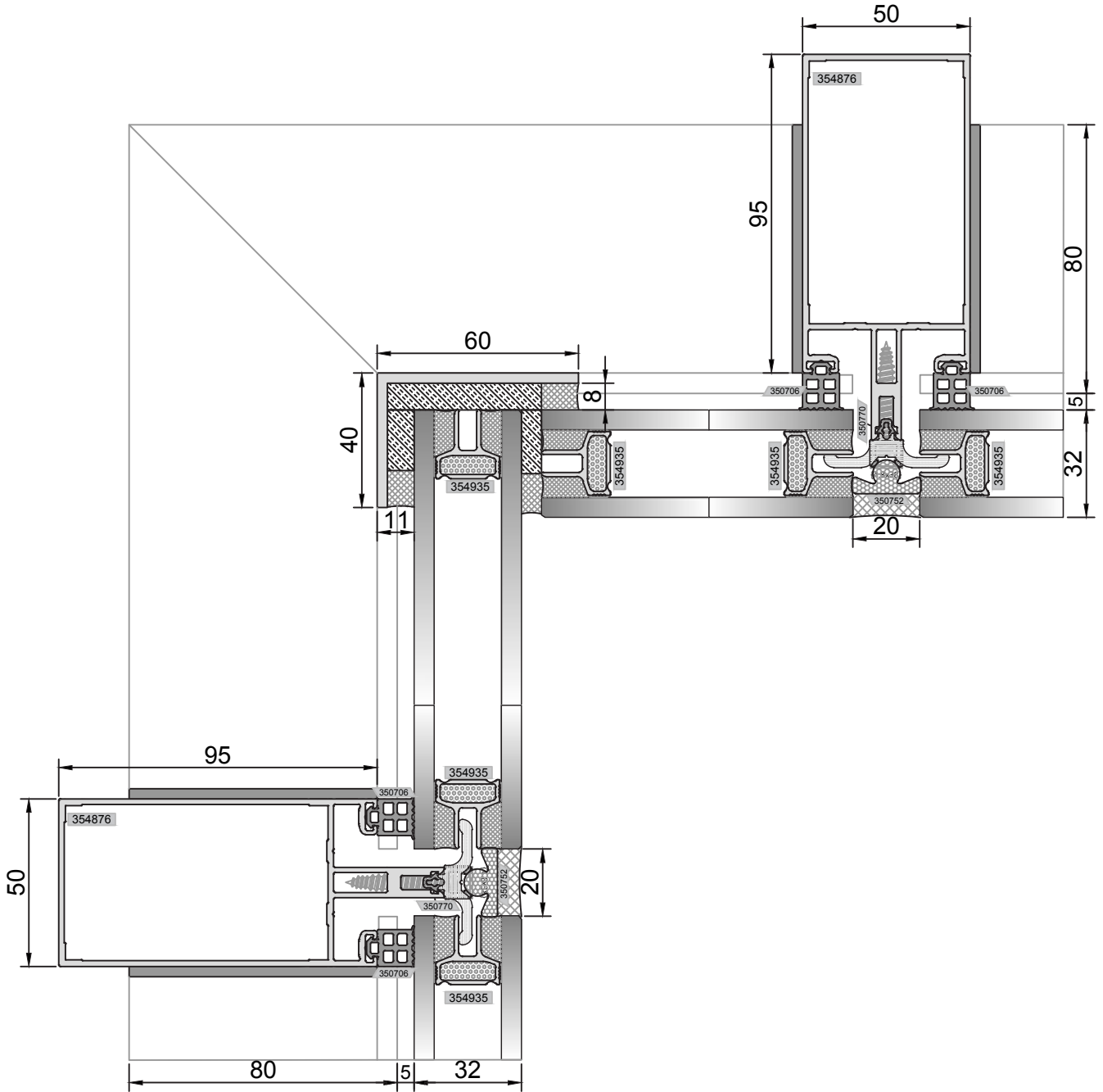
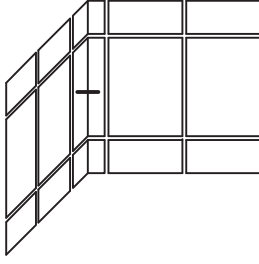

90° İÇ AÇILI CAM CEPHE DÜŞEY KESİT DETAYI
FOUR SIDE WITH 90° INTERNAL ANGLE VERTICAL DETAIL

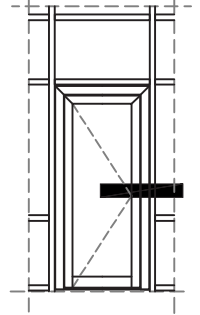
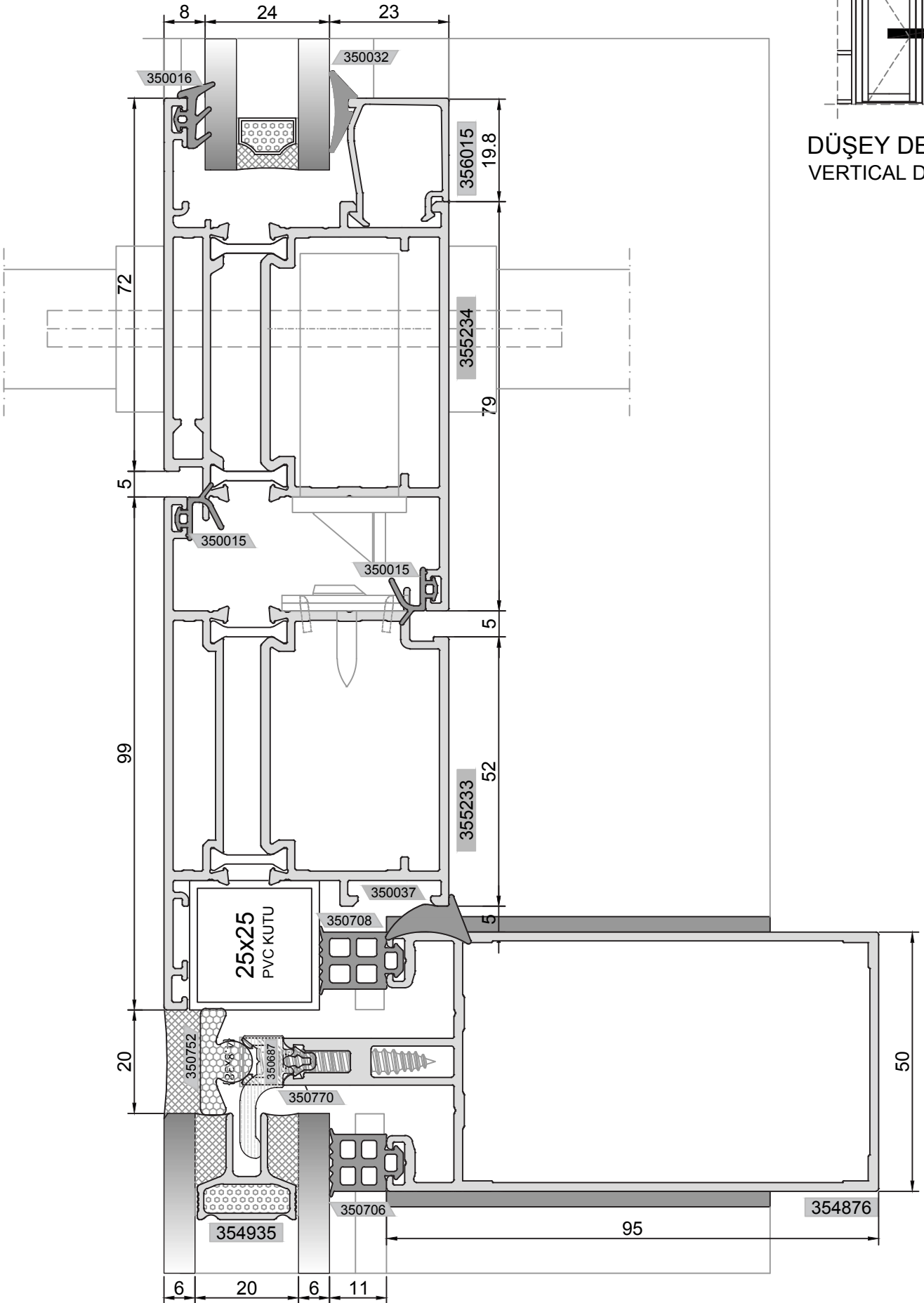

DÜŞEY DETAYI
VERTICAL DETAIL

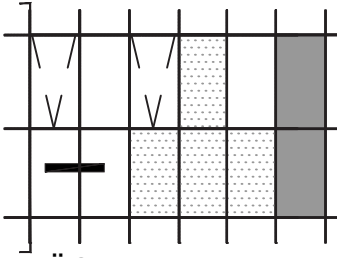

DÜŞEY DETAYI
VERTICAL DETAIL

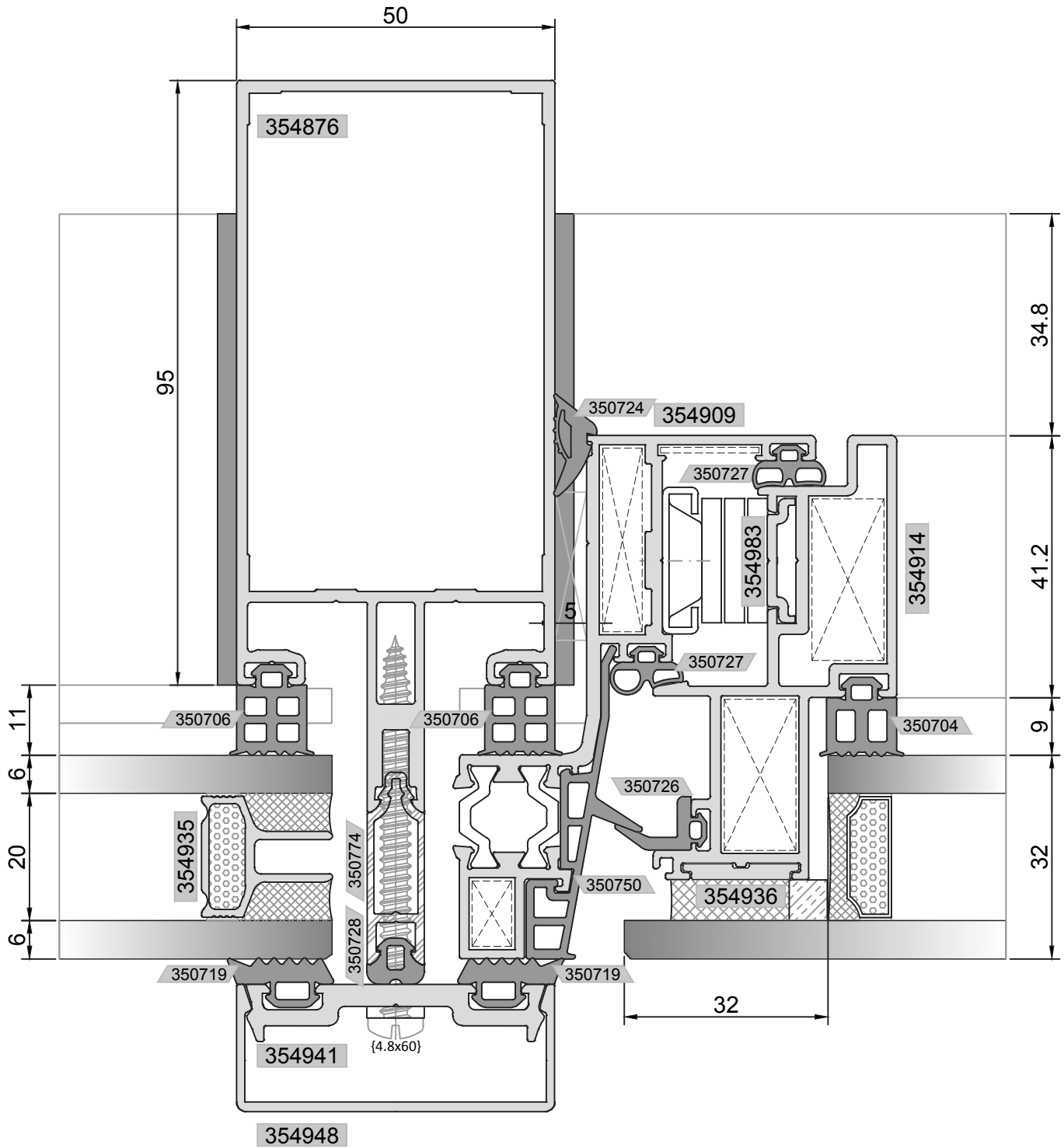

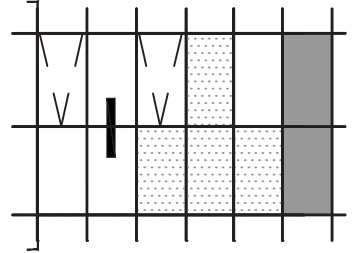

YATAY DETAYI
HORIZONTAL DETAIL

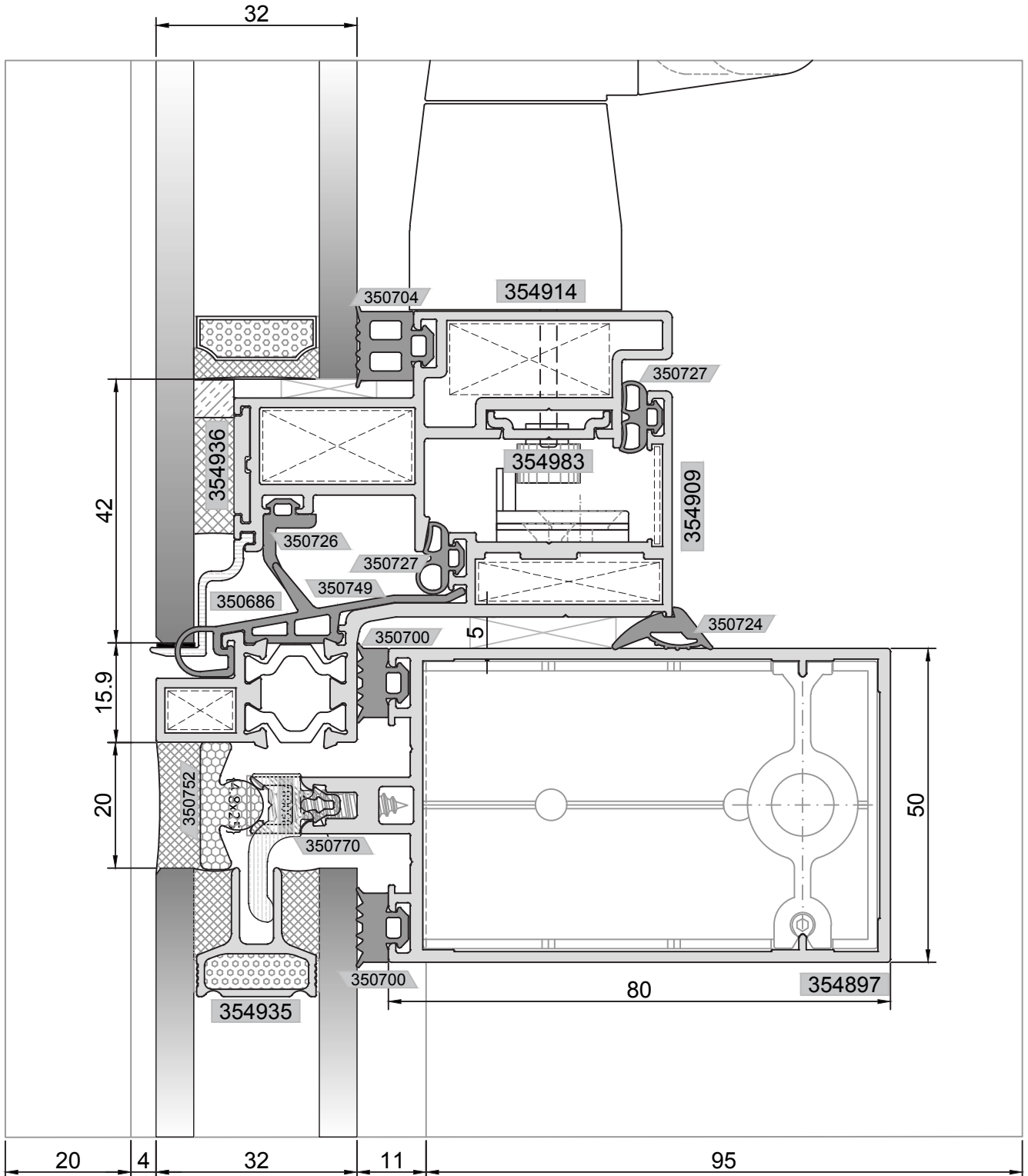

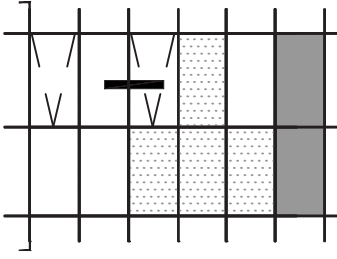

DÜŞEY DETAYI
VERTICAL DETAIL

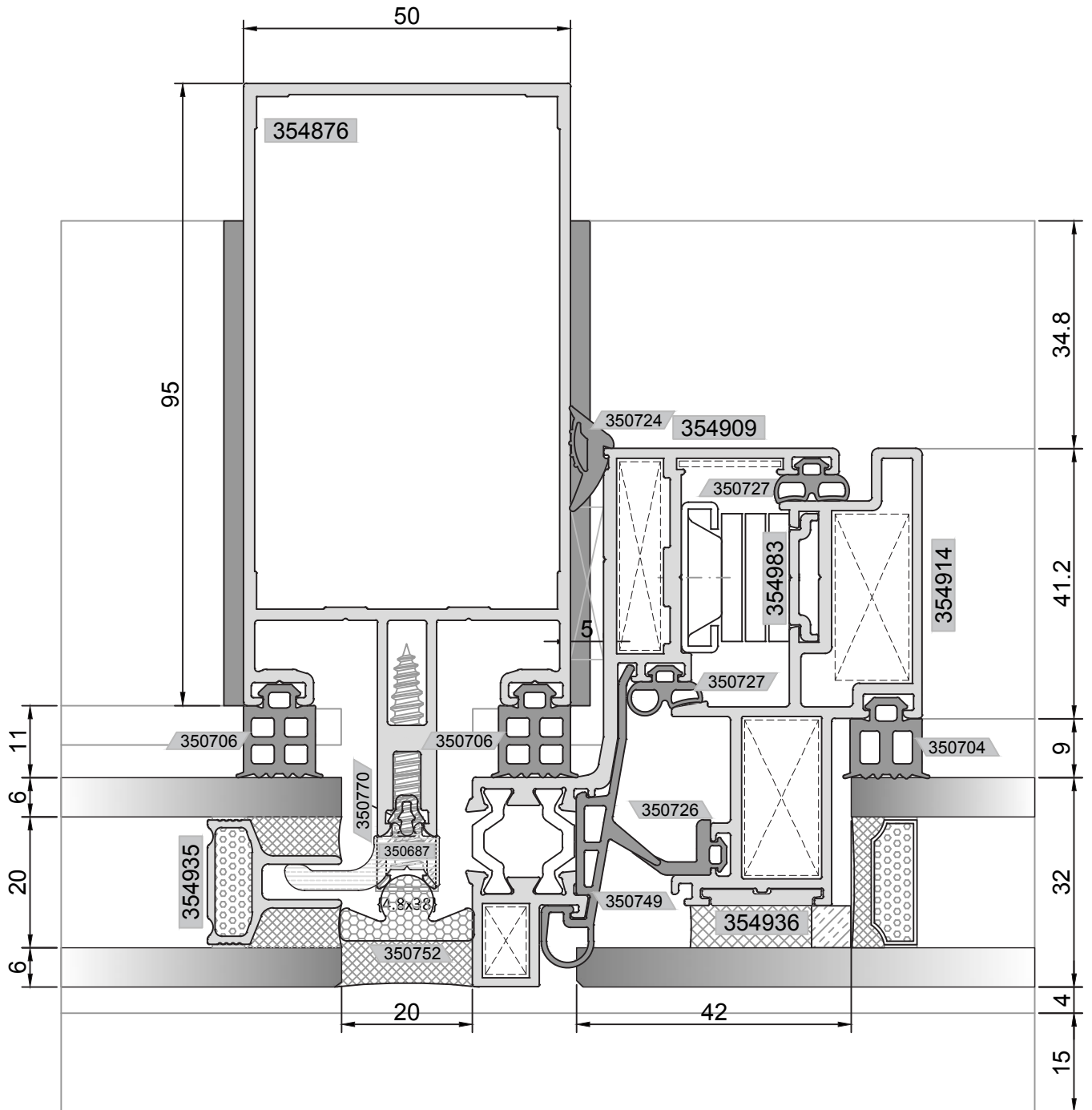

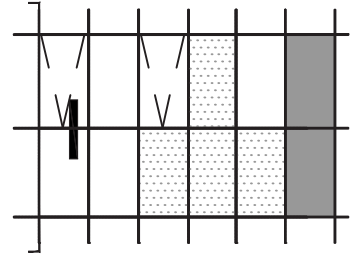

YATAY DETAYI
HORIZONTAL DETAIL

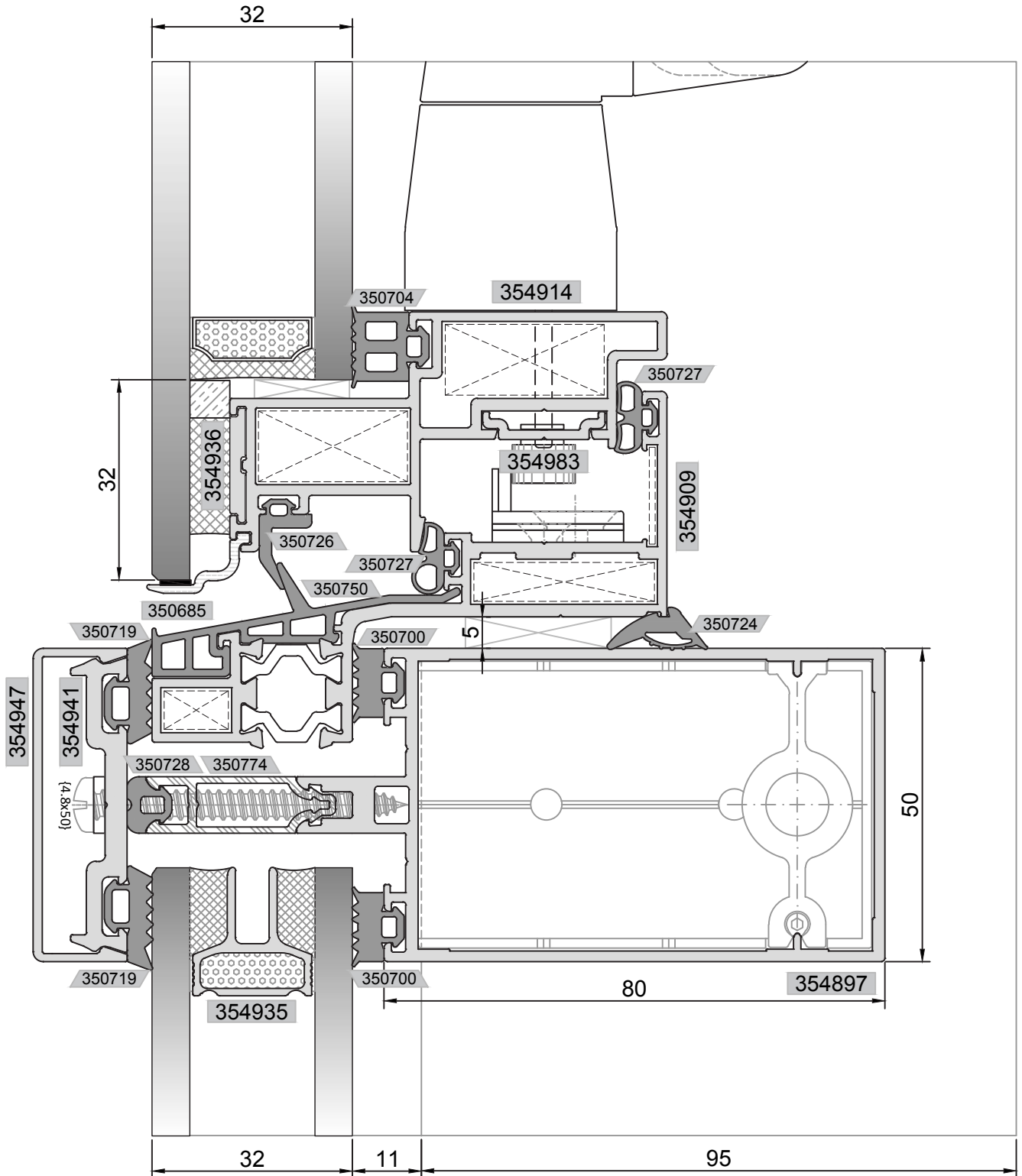

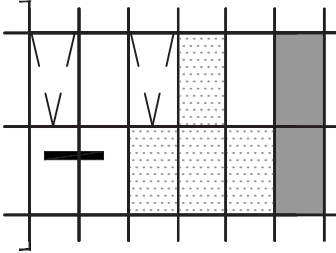

DÜŞEY DETAYI
VERTICAL DETAIL

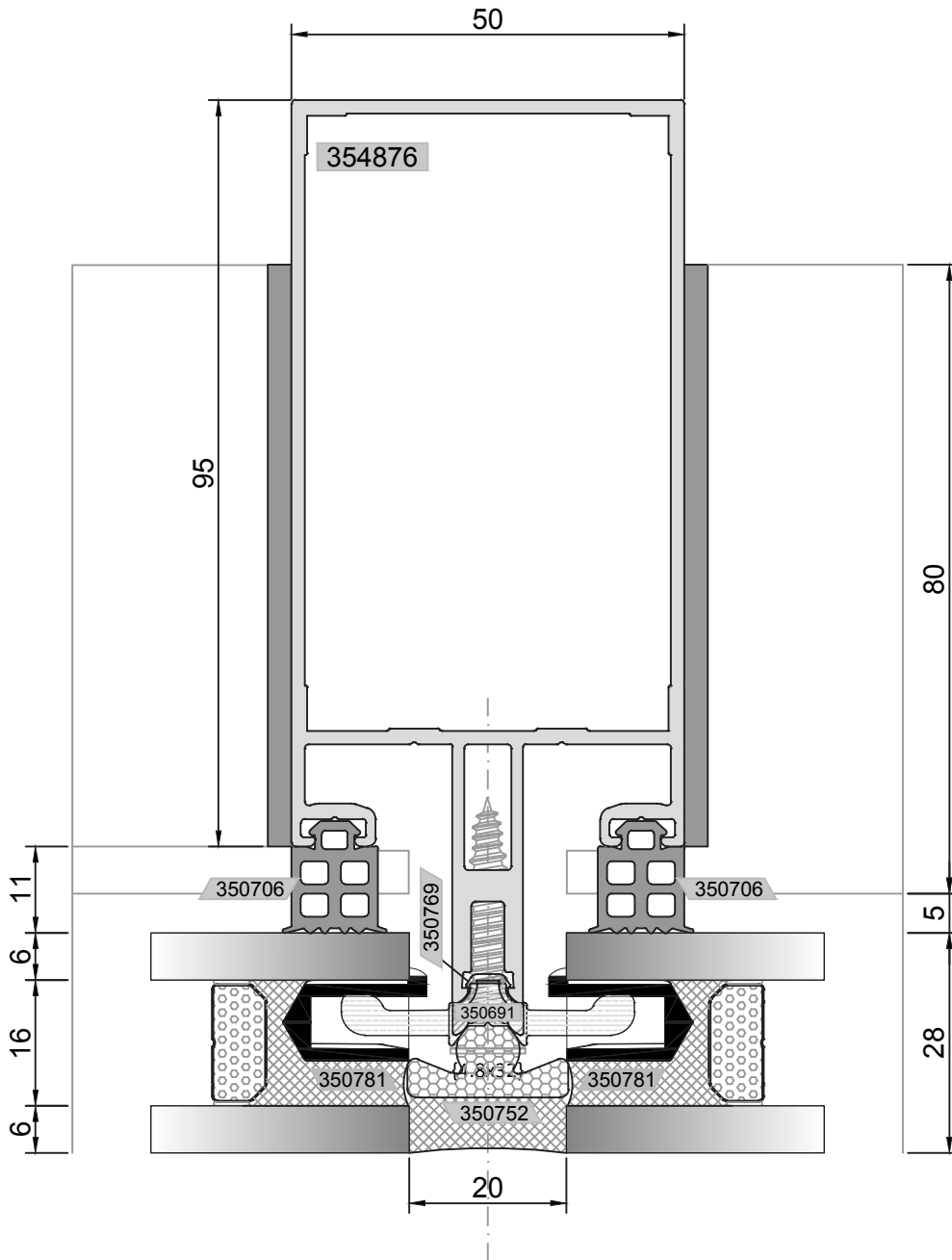

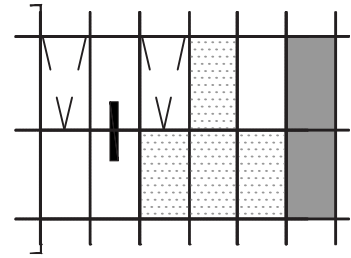

YATAY DETAYI
HORIZONTAL DETAIL

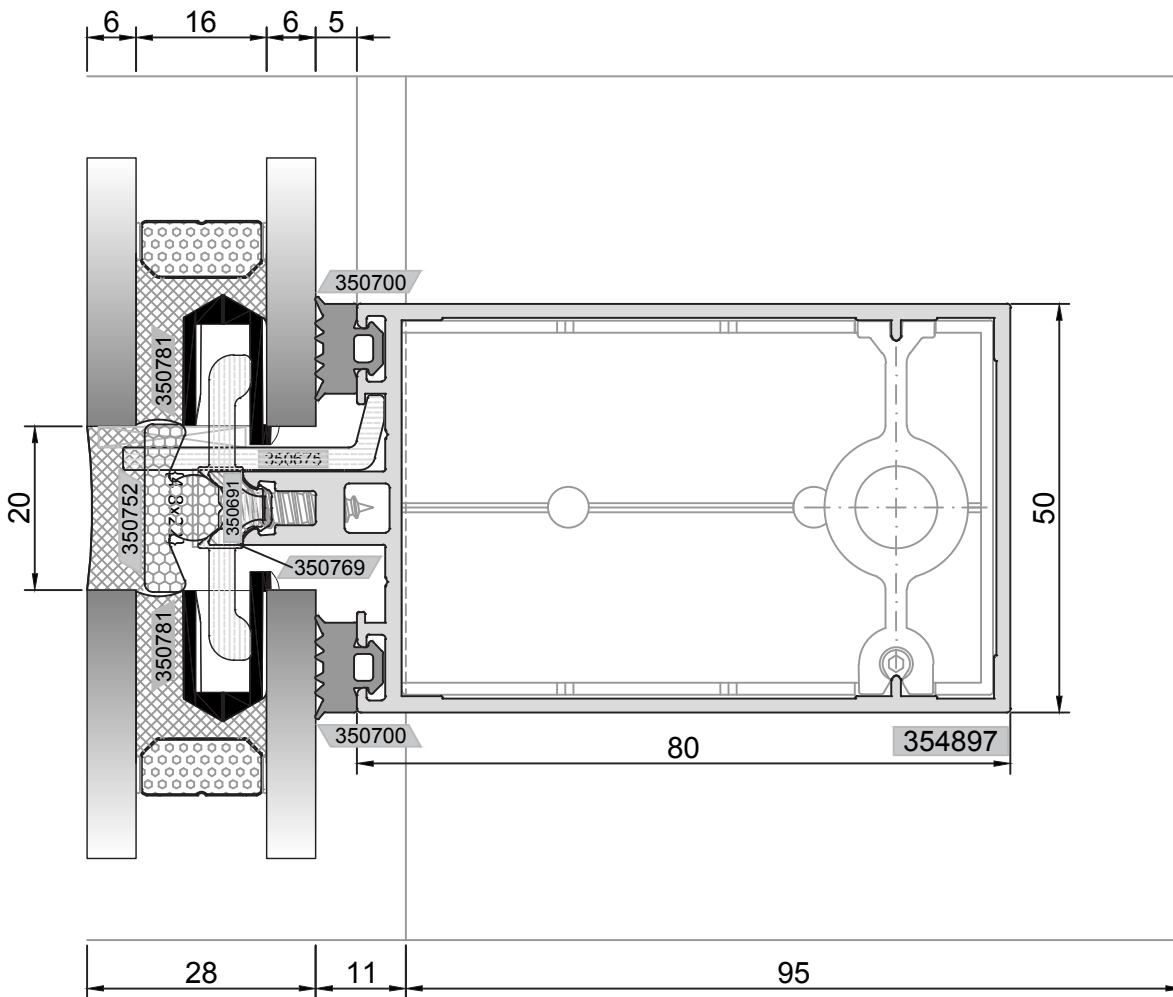

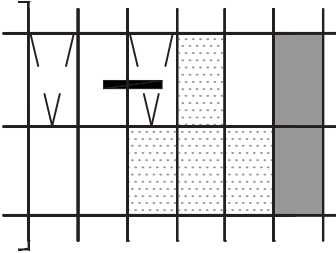

DÜŞEY DETAYI
VERTICAL DETAIL

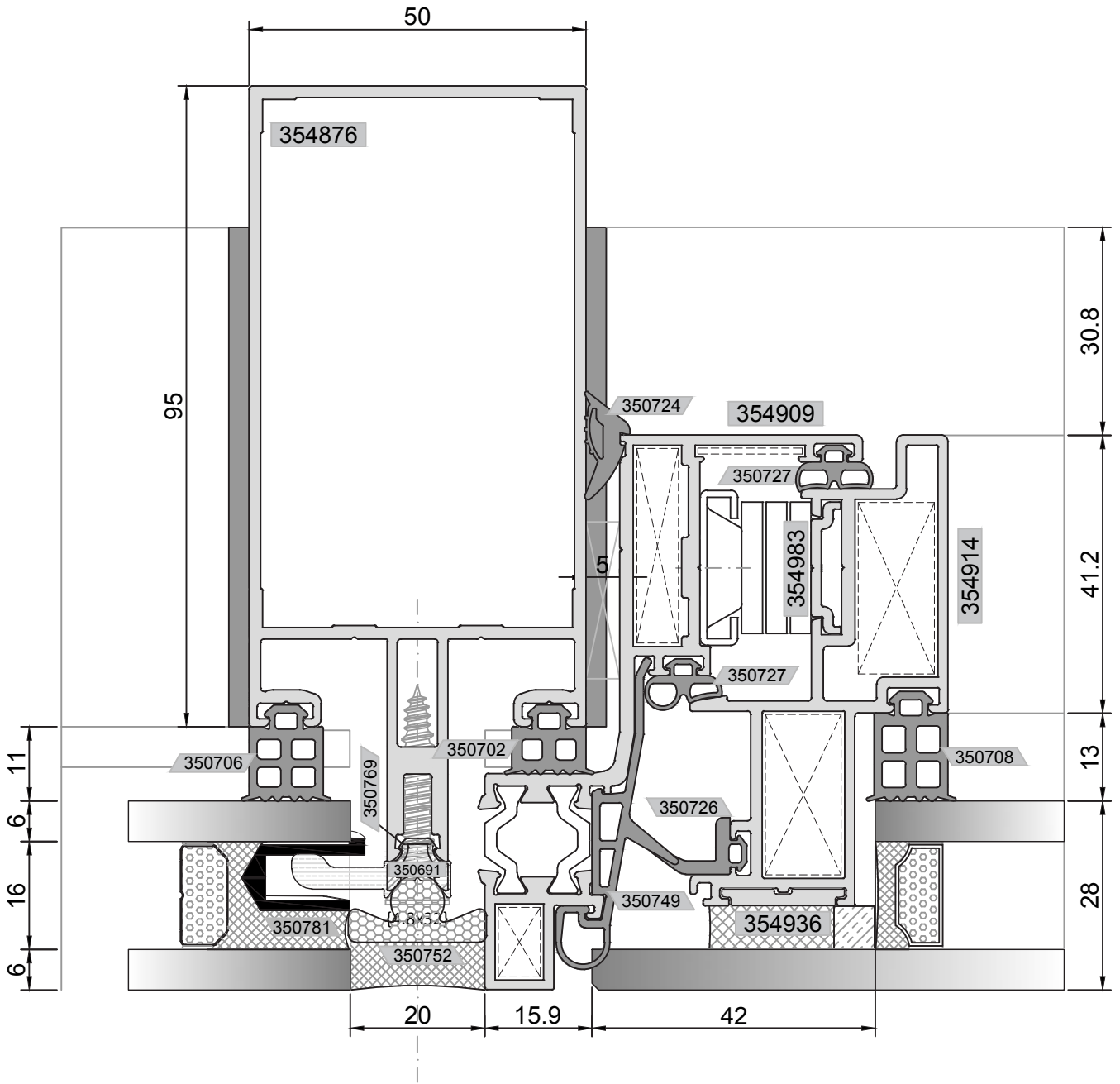

ALTERNATİF 1: YALITIMSIZ KANAT DETAYI
ALTERNATIVE 1 : UNINSULATED VENT DETAIL

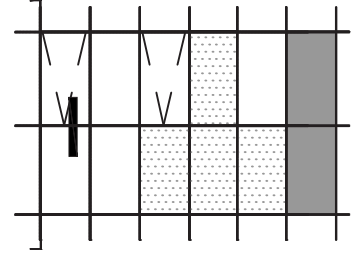

YATAY DETAYI
HORIZONTAL DETAIL

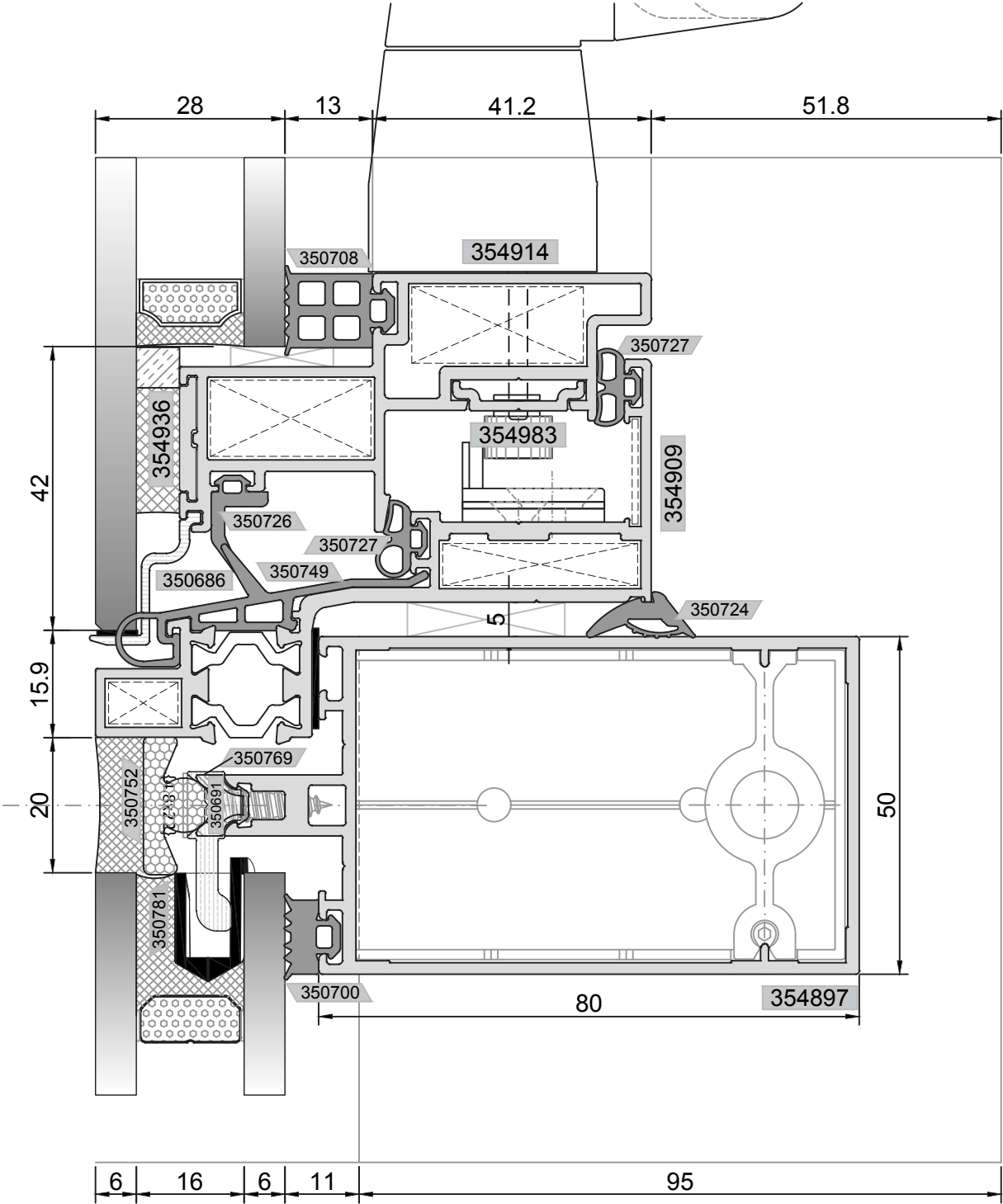

ALTERNATİF 1: YALITIMSIZ KANAT DETAYI
ALTERNATIVE 1 : UNINSULATED VENT DETAIL

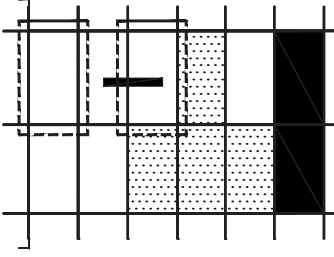

DÜŞEY DETAYI
VERTICAL DETAIL

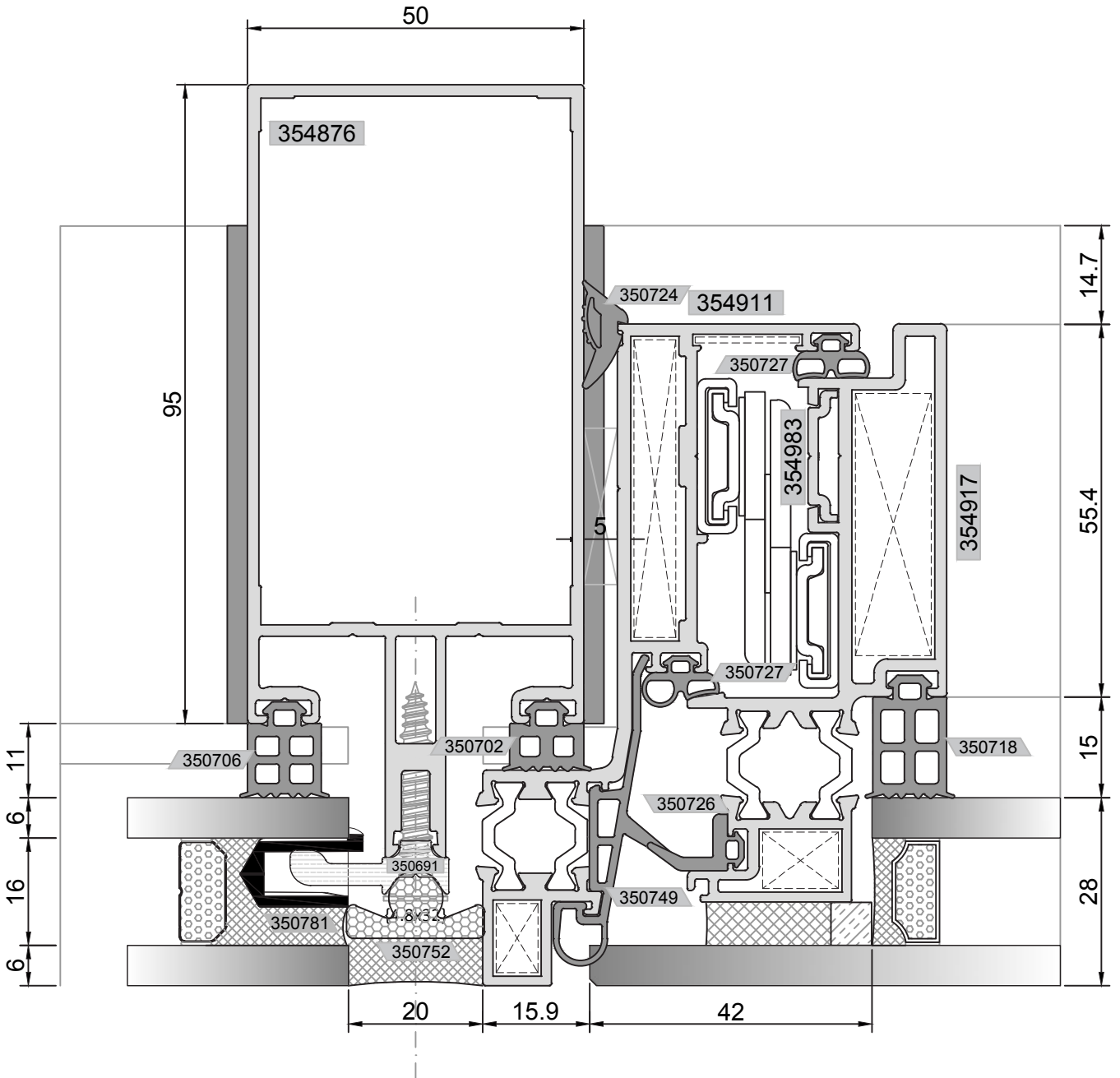

ALTERNATİF 1: YALITIMLI PARALEL AÇILIR KANAT DETAYI
ALTERNATIVE 1 : PARALEL OPENING INSULATED VENT DETAIL

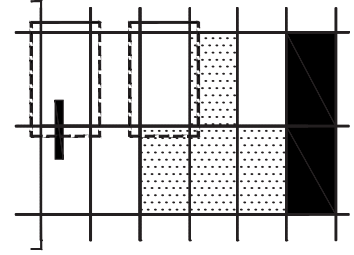

YATAY DETAYI
HORIZONTAL DETAIL

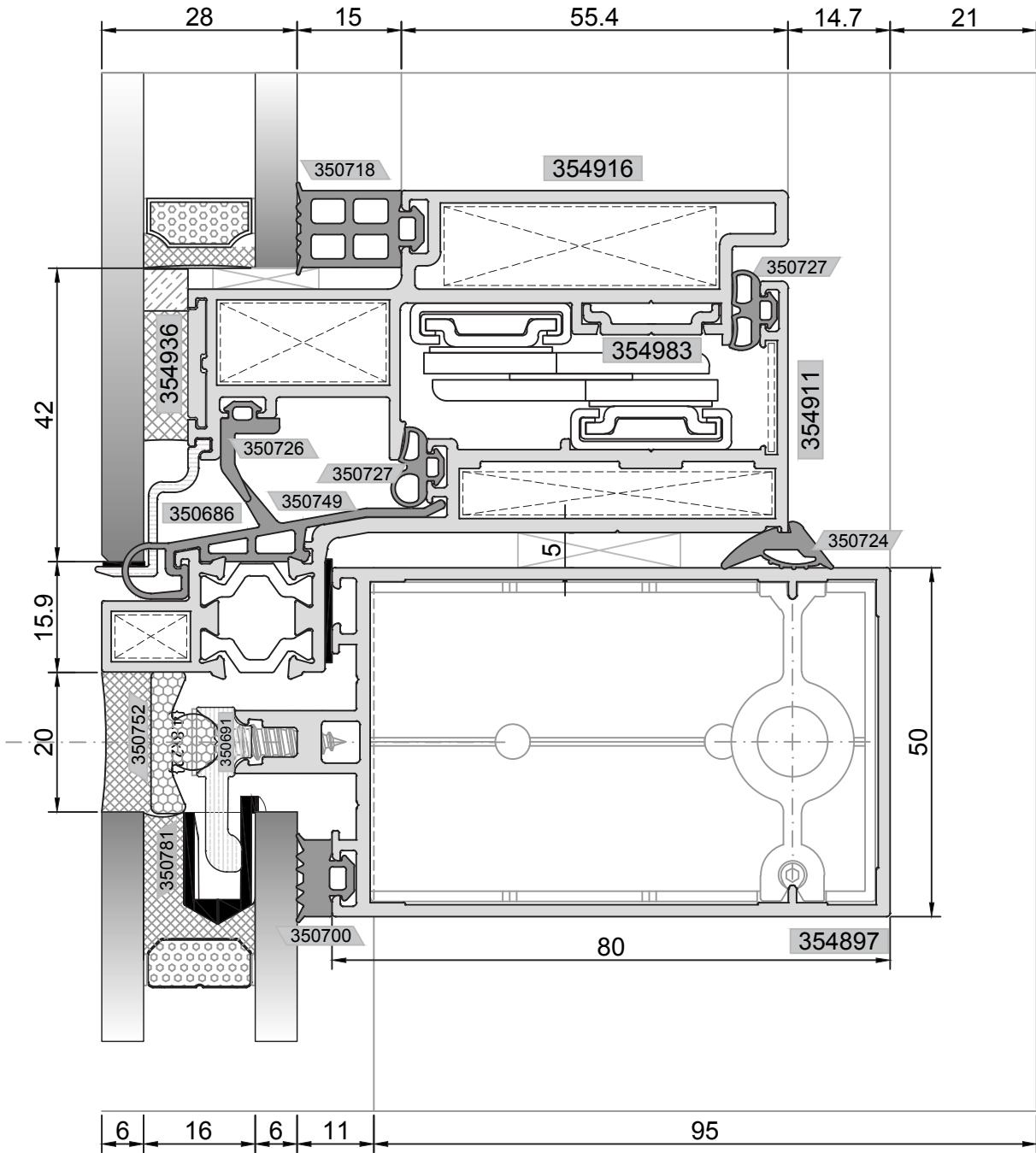

ALTERNATİF 2: YALITIMSIZ PARALEL AÇILIR KANAT DETAYI
ALTERNATIVE 2 : PARALEL OPENING UNINSULATED VENT DETAIL

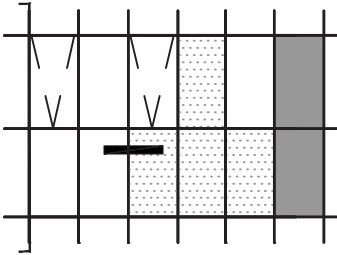

DÜŞEY DETAYI
VERTICAL DETAIL

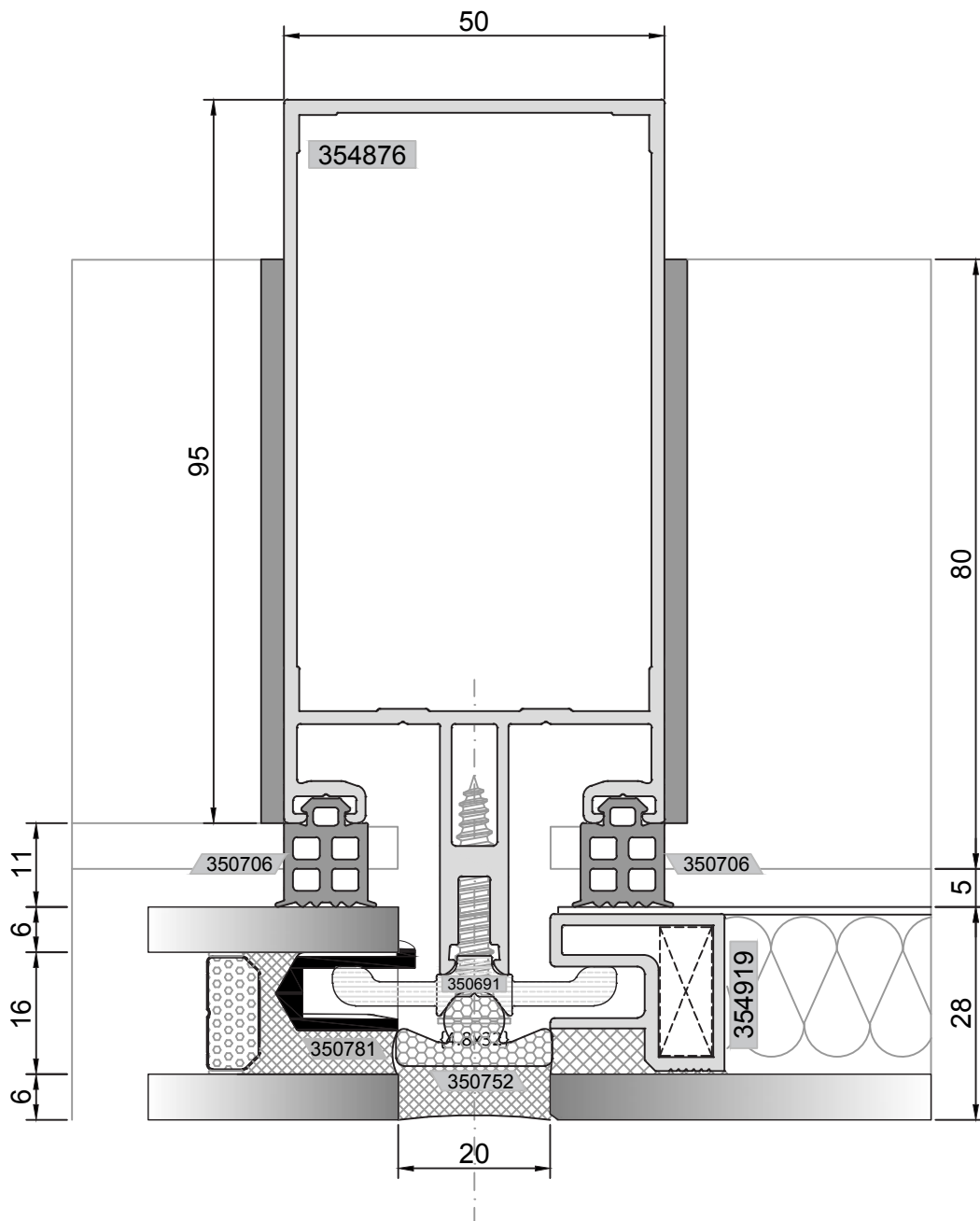

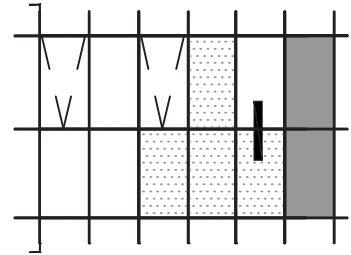

YATAY DETAYI
HORIZONTAL DETAIL

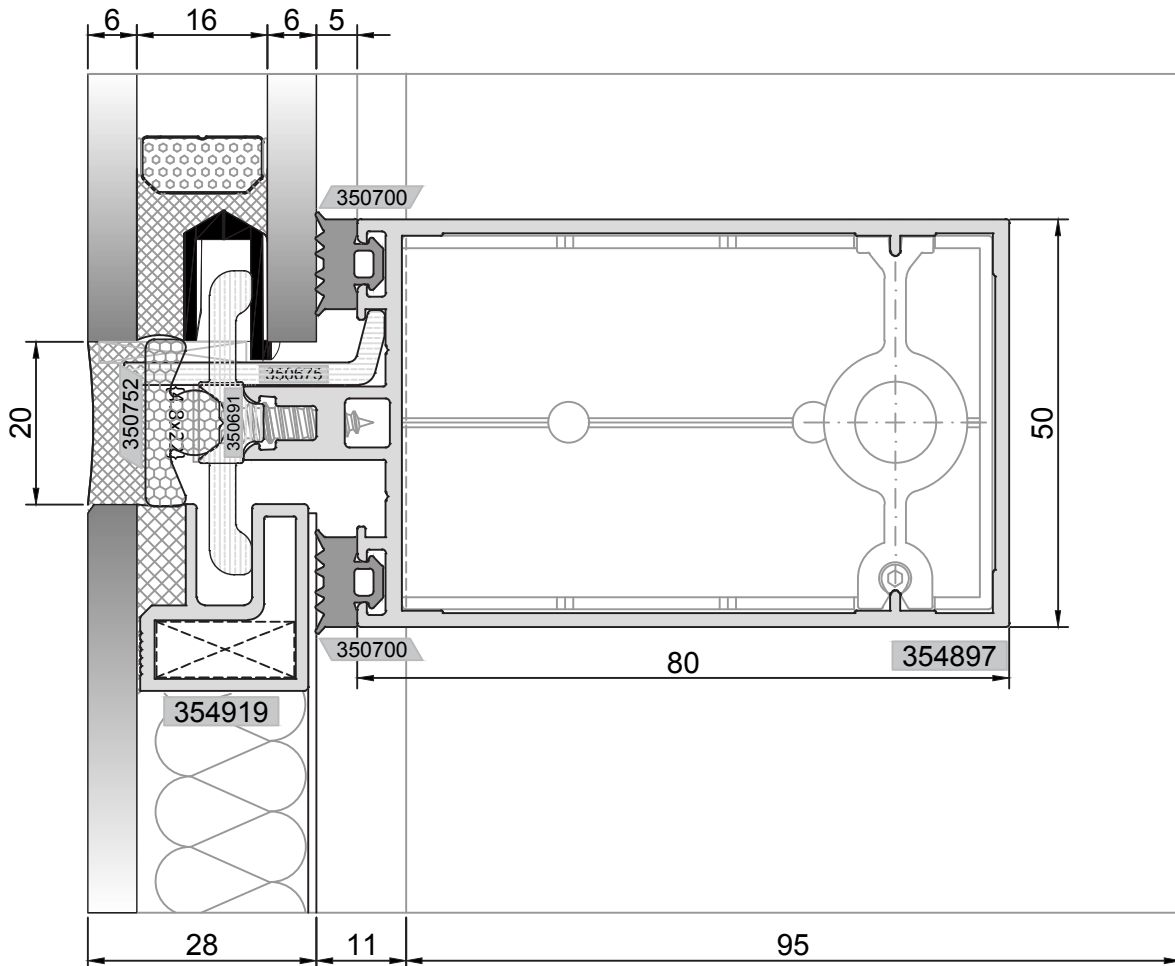

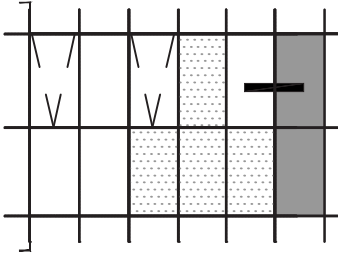

DÜŞEY DETAYI
VERTICAL DETAIL

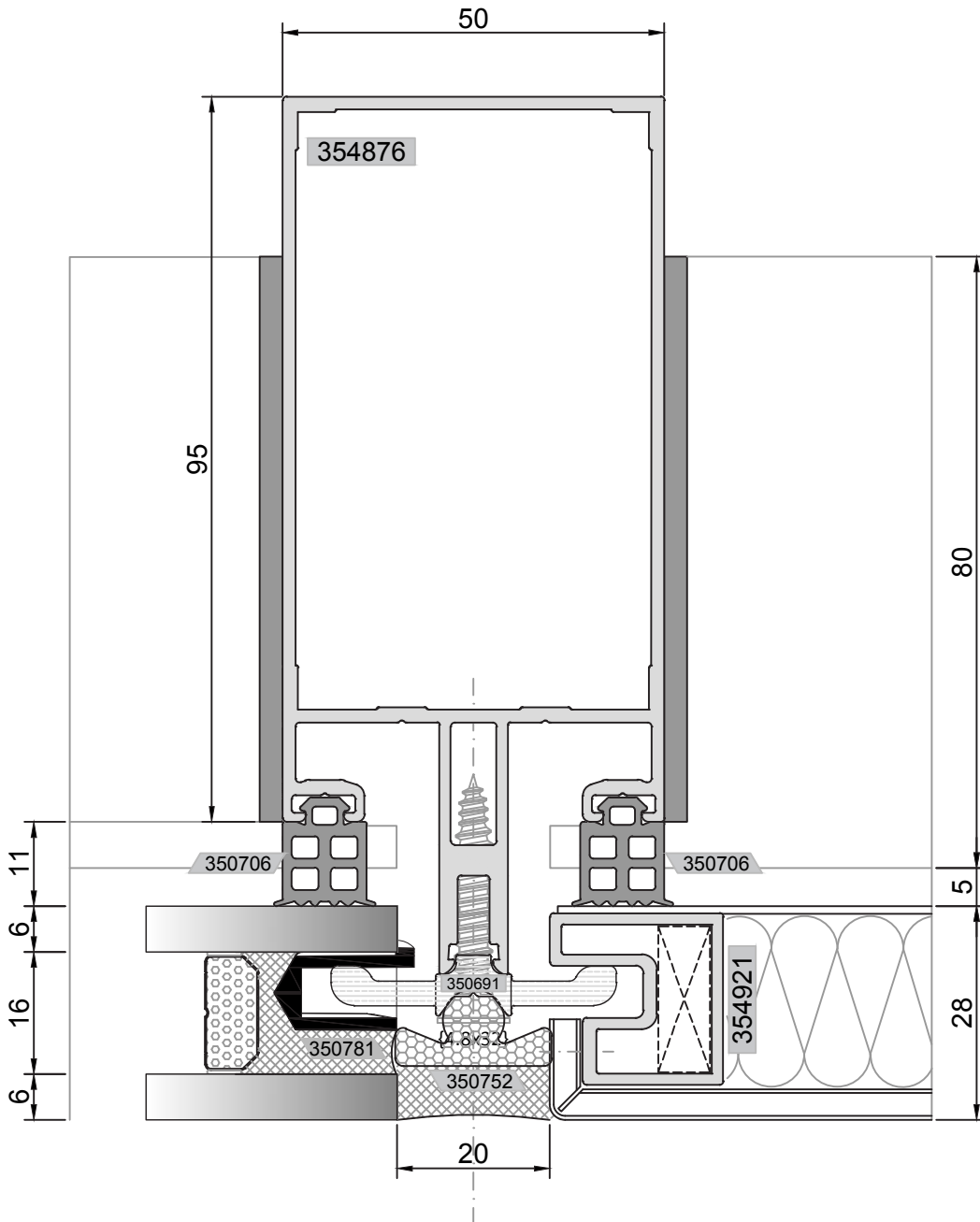

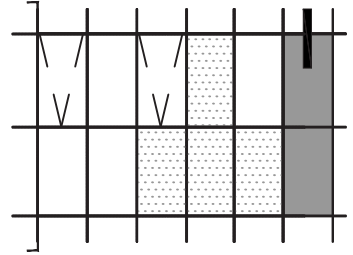

YATAY DETAYI
HORIZONTAL DETAIL

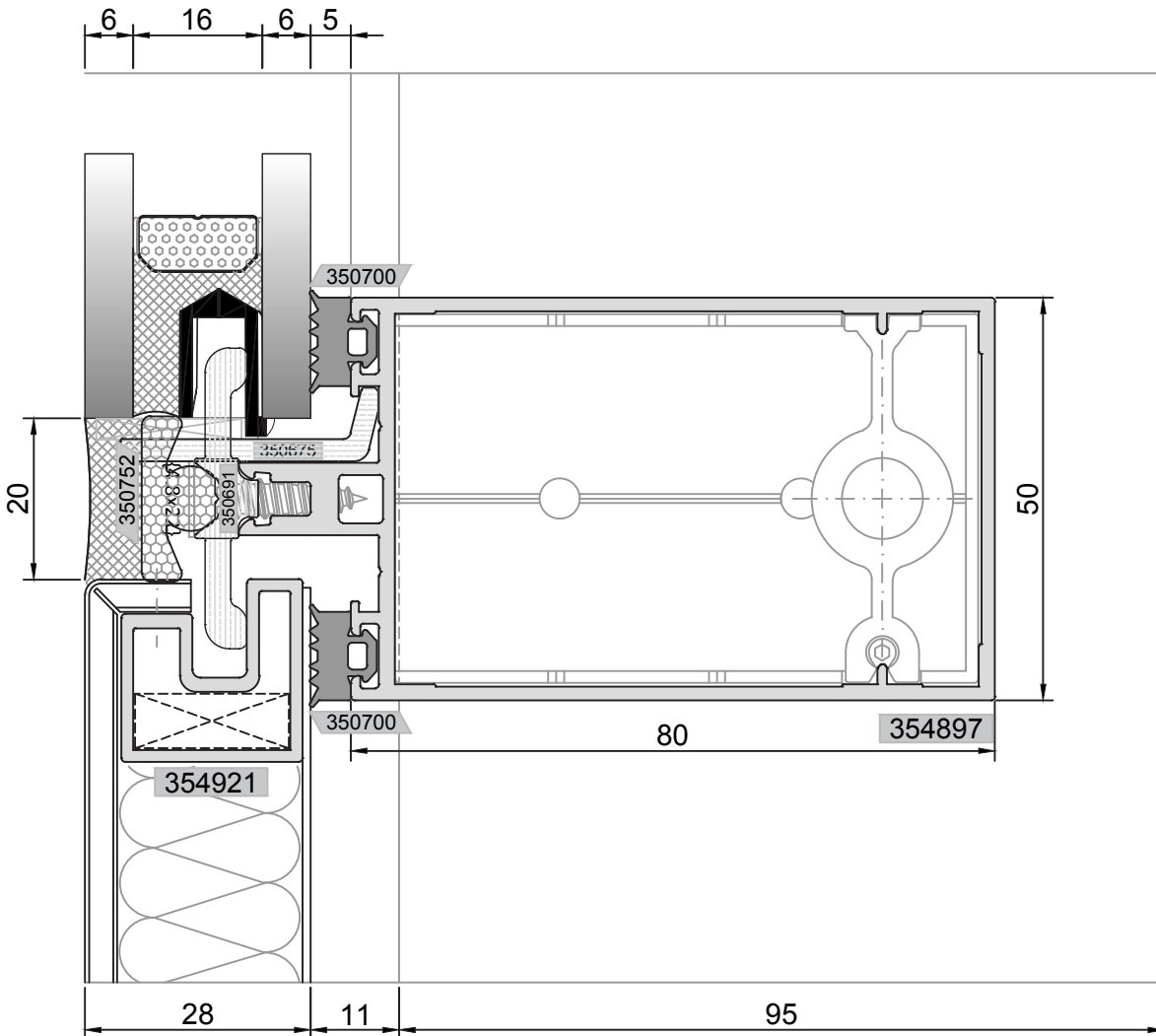

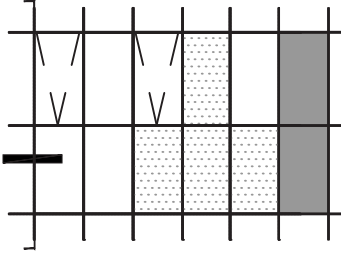

DÜŞEY DETAYI
VERTICAL DETAIL

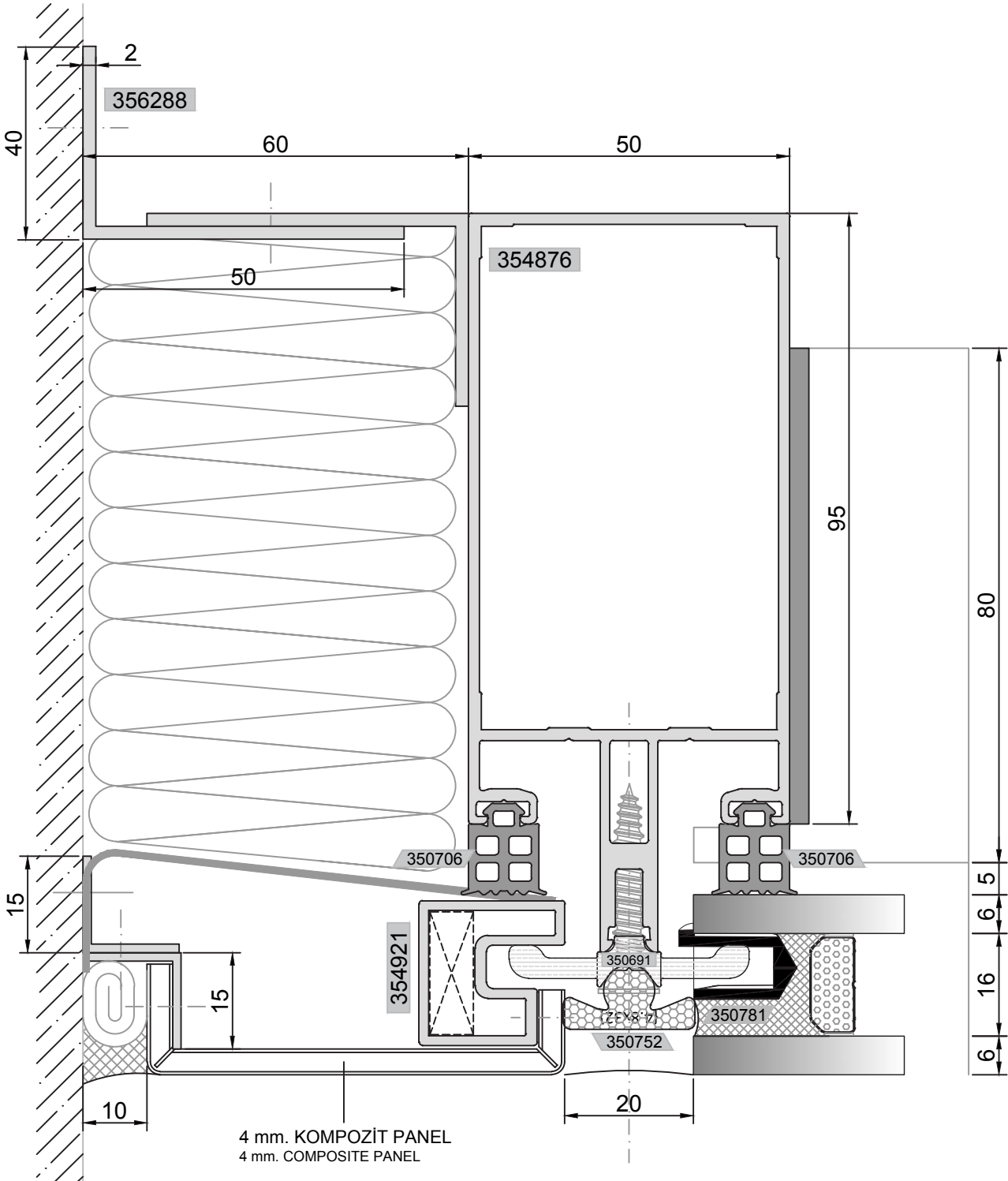

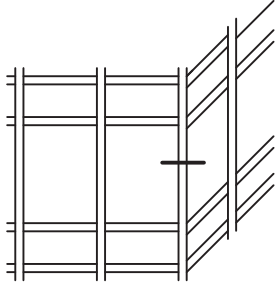

90°

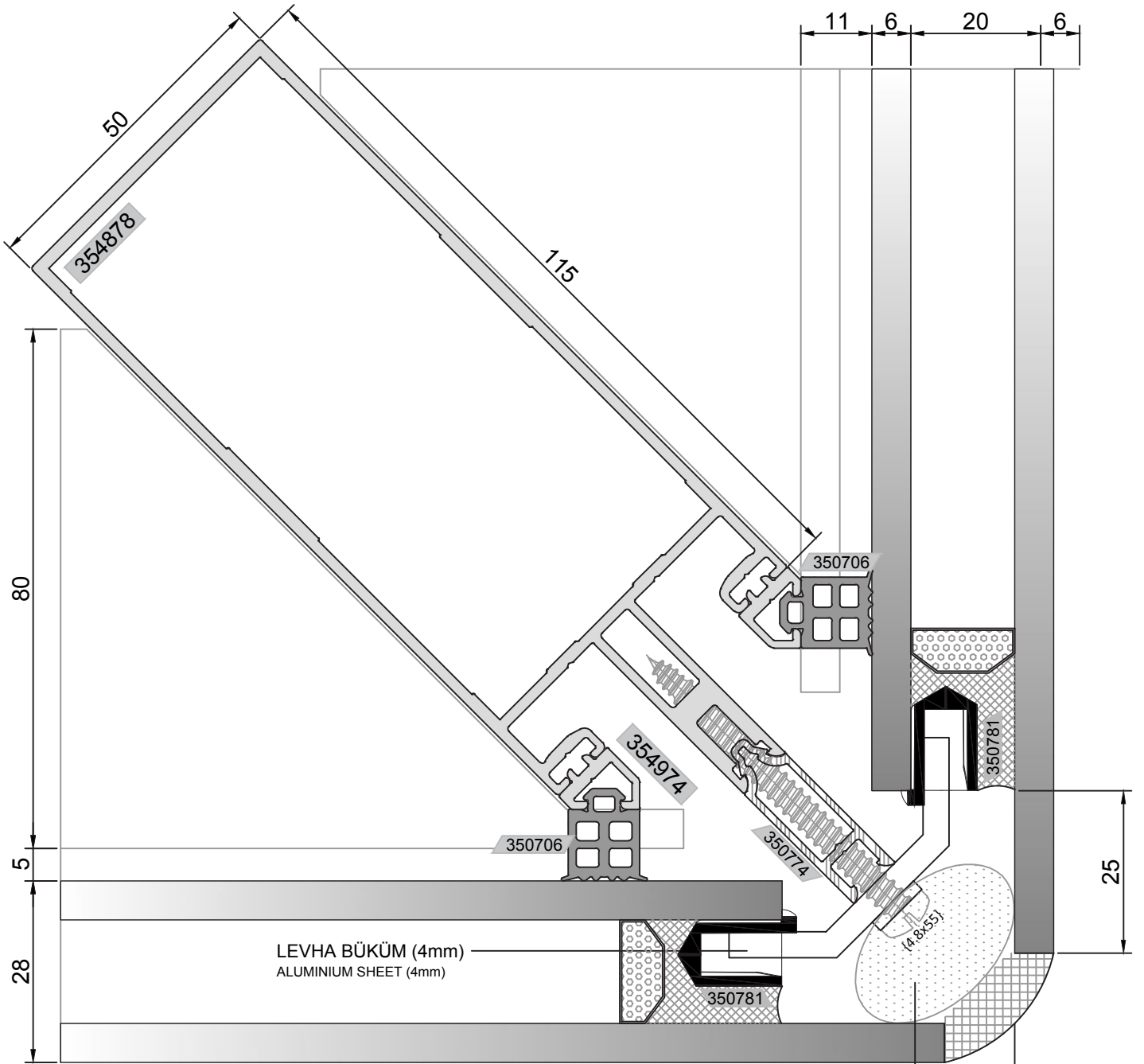

ALTERNATİF 1: TEK DİKMELİ KÖŞE DETAYI
ALTERNATIVE 1 : CORNER DETAIL WITH SINGLE MULLION

POLİETİLEN CONTA
POLYETHYLENE GASKET

SİLİKON
SILICONE

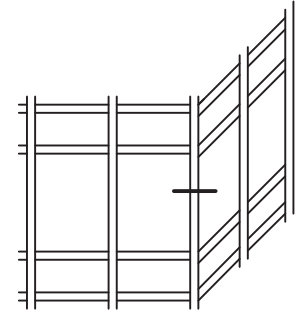

90°

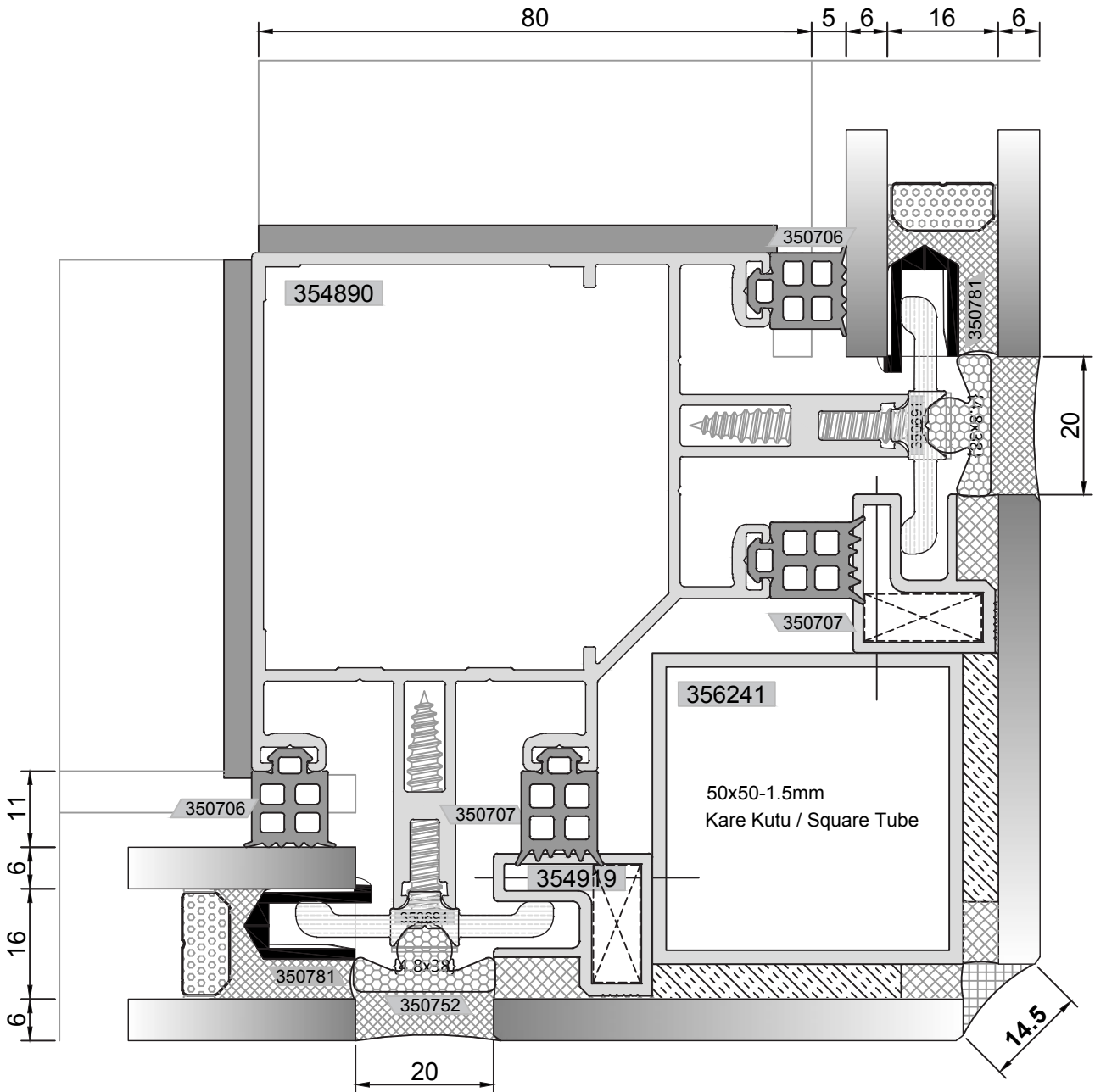

ALTERNATİF 2: ÇİFT DİKMELİ KÖŞE DETAYI
ALTERNATIVE 2 : CORNER DETAIL WITH DOUBLE MULLION

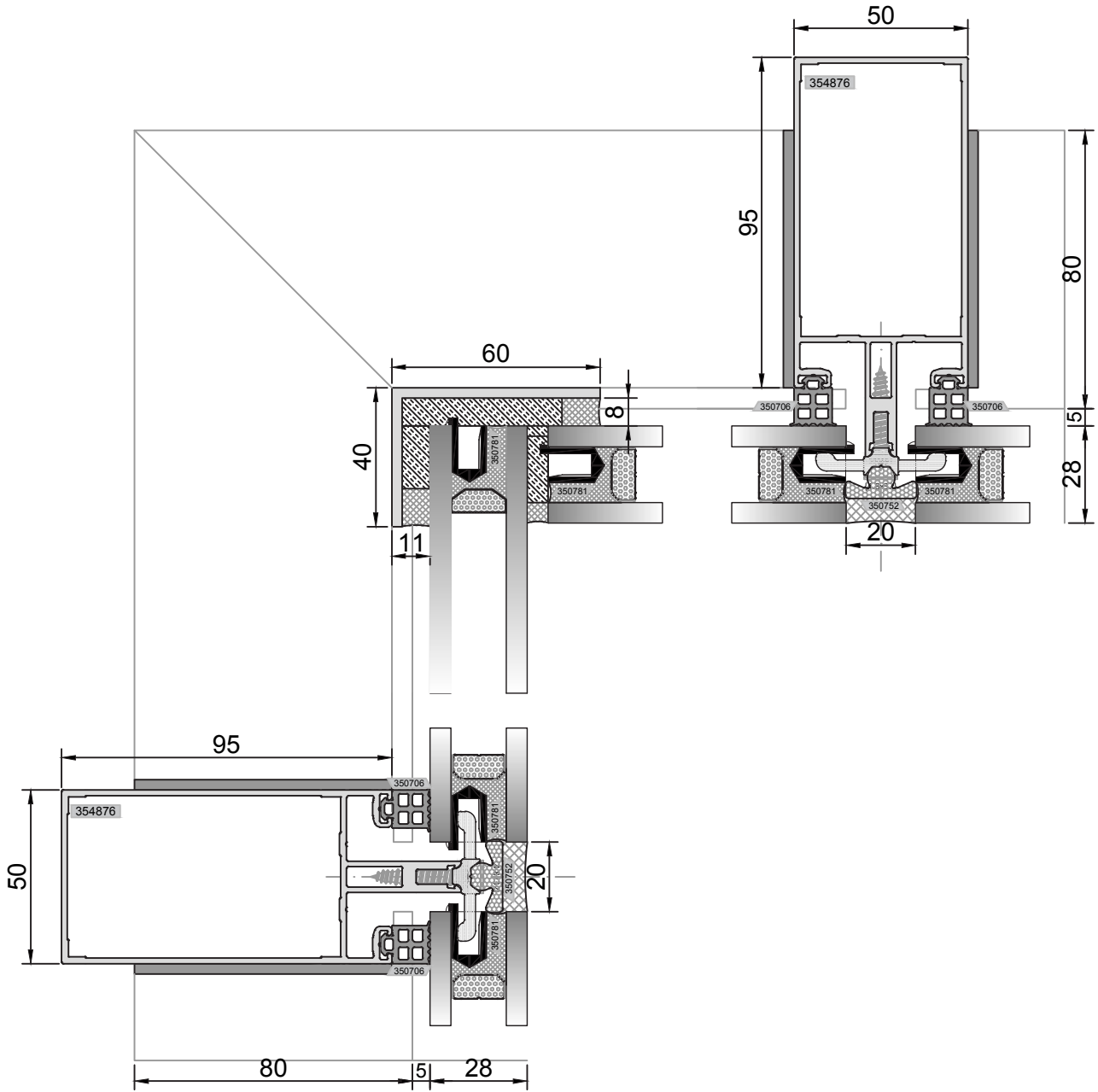
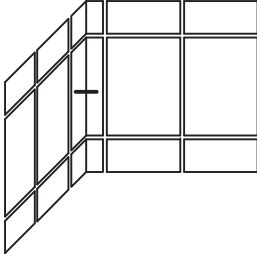

90° İÇ AÇILI CAM CEPHE DÜŞEY KESİT DETAYI
FOUR SIDE WITH 90° INTERNAL ANGLE VERTICAL DETAIL

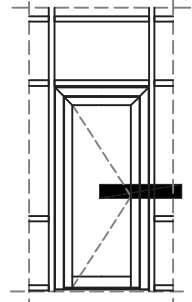
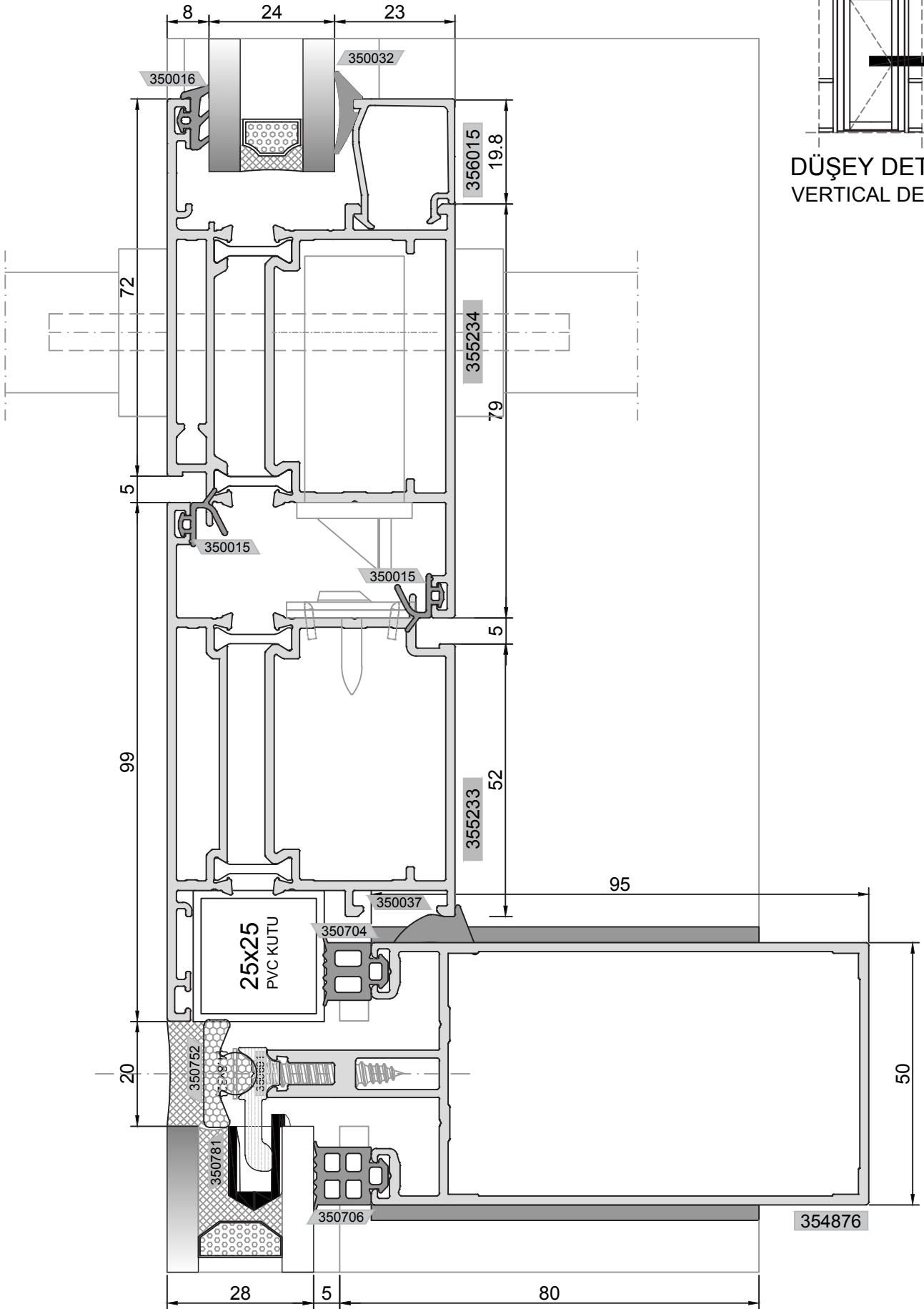

DÜŞEY DETAYI
VERTICAL DETAIL

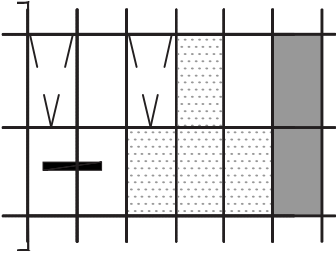

DÜŞEY DETAYI
VERTICAL DETAIL

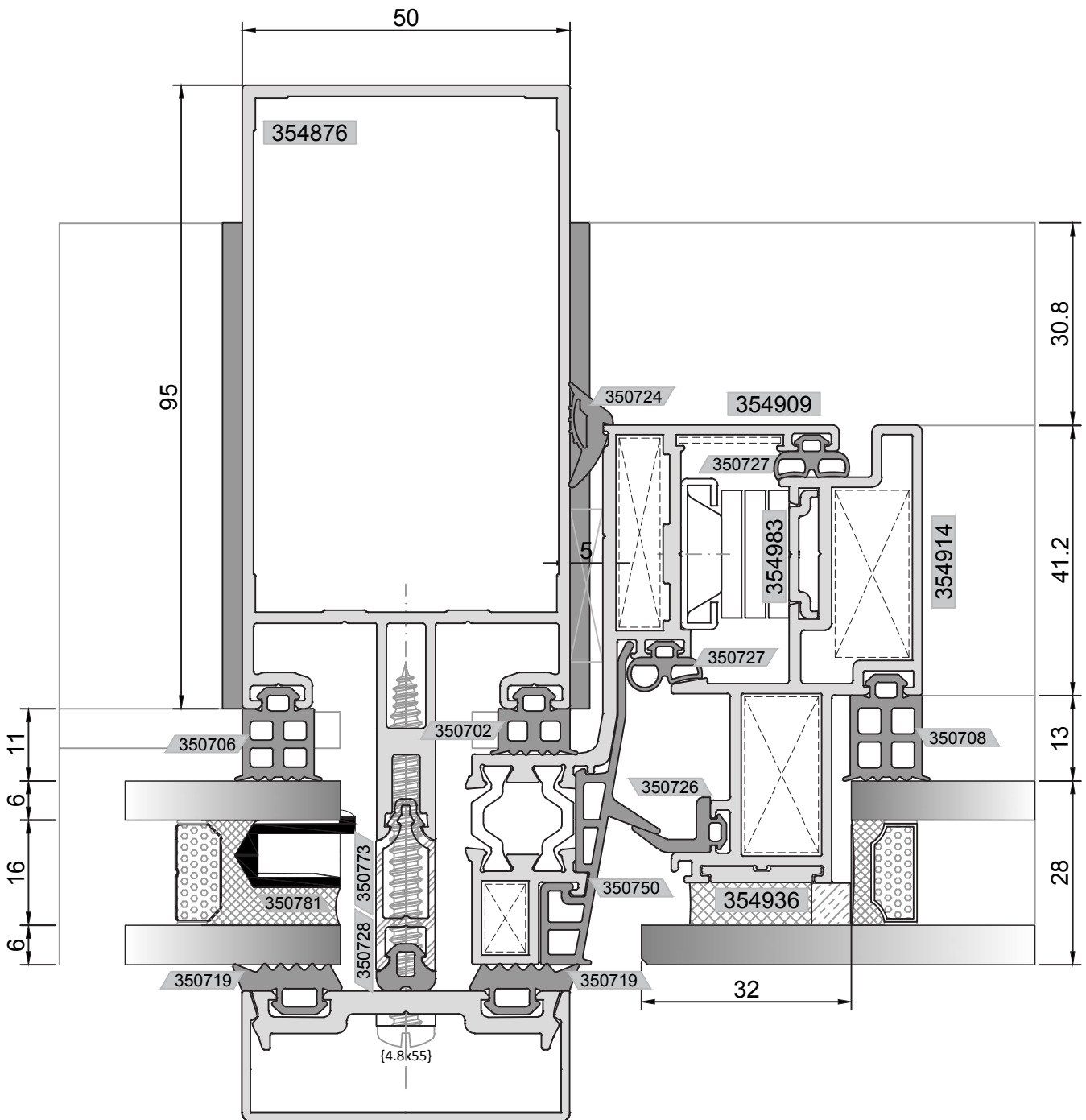

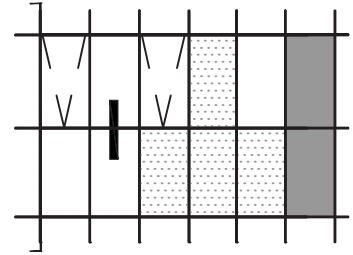

YATAY DETAYI
HORIZONTAL DETAIL

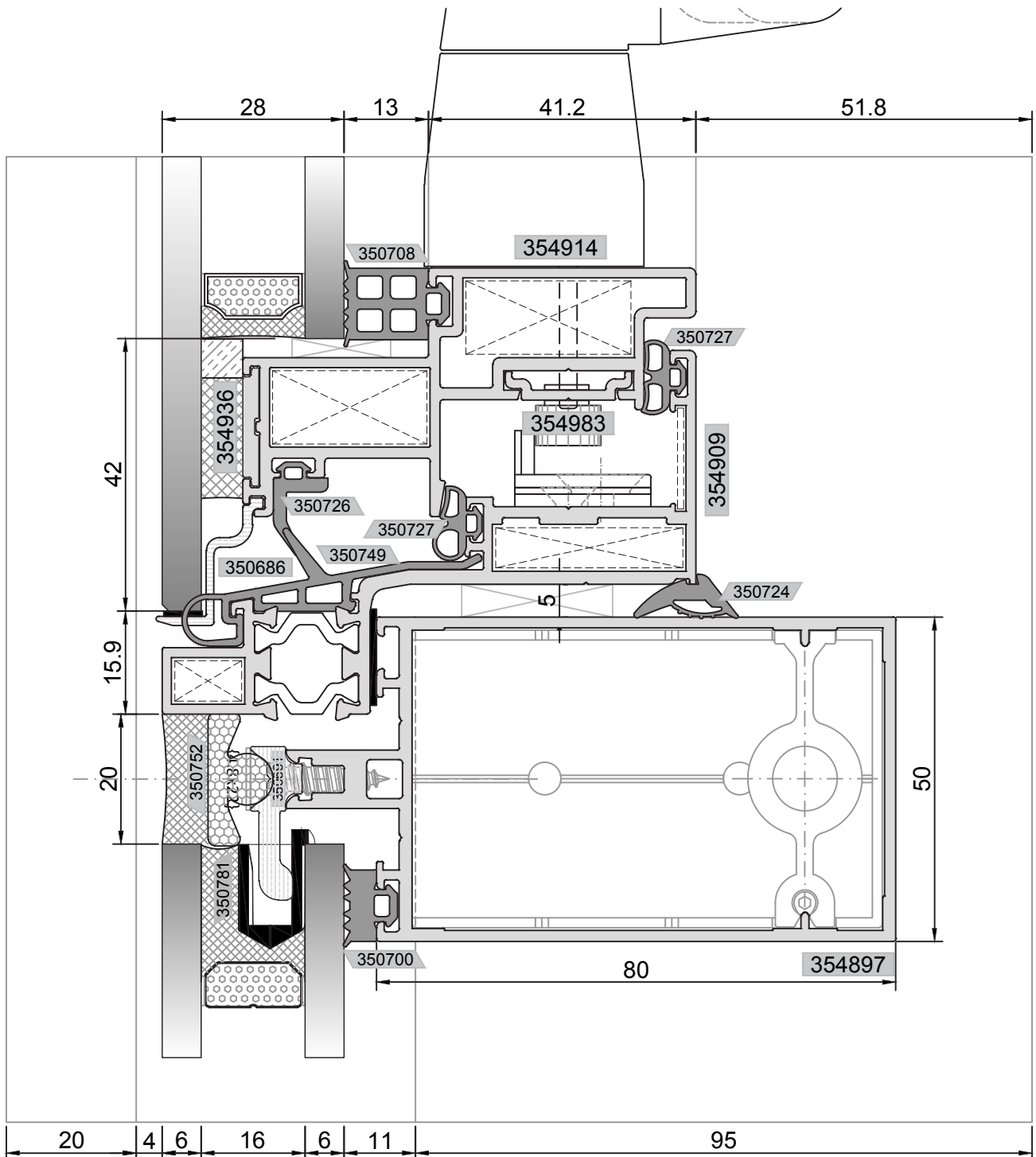

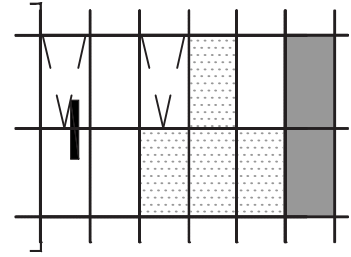

YATAY DETAYI
HORIZONTAL DETAIL

